

California Environmental Protection Agency



**Test Procedure for Determining Integrity of
Spill-Proof Spouts and Spill-Proof Systems**

TP - 501

Adoption Date:[to be determined]

TABLE OF CONTENTS

	Page
1. APPLICABILITY.....	3
2. PRINCIPAL AND SUMMARY OF TEST PROCEDURE	3
3. BIASES AND INTERFERENCES.....	3
4. SENSITIVITY, RANGE, AND PRECISION.....	3
5. EQUIPMENT	4
6. CALIBRATION PROCEDURE	4
7. TEST PROCEDURE.....	4
7.1 System Preparation.....	4
7.2 Verify Leak Free System	4
7.3 Verify Automatic Closure.....	4
7.4 Pressurized Leak Check	5
8. QUALITY ASSURANCE / QUALITY CONTROL (QA/QC).....	5
9. RECORDING DATA.....	5
10. CALCULATING RESULTS	5
11. ALTERNATIVE TEST PROCEDURES	5
12. REFERENCES	6
13. FIGURES.....	6
<i>Figure 1. Field Data Sheet</i>	<i>6</i>
<i>Figure 2. Test Fixture.....</i>	<i>6</i>
<i>Figure 3. Elevated Pressure Test Setup.....</i>	<i>6</i>

**California Environmental Protection Agency
Air Resources Board**

**Test Procedure for Determining Integrity of
Spill-Proof Spouts and Spill-Proof Systems**

The definitions in Section 2467.1, Article 6, Chapter 9 of Title 13, California Code of Regulations (CCR) applies to this test procedure.

For the purpose of this procedure, the term "ARB" refers to the California Air Resources Board, and the term "Executive Officer" refers to the ARB Executive Officer or his or her authorized representative or designate.

1. APPLICABILITY

This Test Procedure is used to verify the performance of the automatic closure and leak free features of spill-proof systems or spill-proof spouts. It is applicable in all cases where portable fuel containers, spouts or both portable fuel containers and spouts are manufactured for sale, sold, advertised for sale, or offered for sale in California or that are introduced, delivered or imported into California for introduction into commerce.

2. PRINCIPAL AND SUMMARY OF TEST PROCEDURE

This procedure is used to verify the performance of the automatic closure and leak free features of a spill-proof spout when installed on a portable fuel container (spill-proof system). Using water, the portable fuel container is filled to its rated capacity and inverted for a period of time for an initial check for leaks. The liquid is then dispensed through the spill-proof spout into a test fixture. The spill-proof spout is allowed to close when approximately 25% of the container rated capacity has been dispensed to verify the automatic closure feature is operational and checked for leaks and liquid retention in any open parts of the spout. This procedure is repeated twice more without refilling the container to check the performance at three different fill levels. The spill-proof system is then pressurized to 5.0 pounds per square inch (psig) with compressed air and immersed in a water bath for five minutes to test for high-pressure leaks.

3. BIASES AND INTERFERENCES

This section is reserved for future specifications.

4. SENSITIVITY, RANGE, AND PRECISION

This section is reserved for future specifications.

5. EQUIPMENT

- 5.1 Test fixture as shown in Figure 2.
- 5.2 Pressure gauge, 0-15 psig, 0.2 psig graduation, Grade 2A accuracy or better.
- 5.3 Pressure gauge adapter and container pressurization assembly as shown in Figure 3.

6. CALIBRATION PROCEDURE

This section is reserved for future specifications.

7. TEST PROCEDURE

7.1 System Preparation

Fill the portable fuel container to its rated capacity with water and attach the spill-proof spout per manufacturer instructions. For spill-proof spouts that are not part of a spill-proof system, select the largest portable fuel container specified for use by the spill-proof spout manufacturer for the test procedure. Fill the selected portable fuel container to its rated capacity with water and attach the spill-proof spout per manufacturer instructions. This assembly is now considered a spill-proof system.

7.2 Verify Leak Free System

Invert the spill-proof system with the spout in a vertical axis position for a period of five minutes to ensure that there are no leaks. Record the outcome on the field data sheet (see Figure 1). If the spill-proof system is observed leaking, place the spill-proof system in the upright position and ensure that the spill-proof spout is correctly and firmly attached. Invert the container again for a period of five minutes and check for leaks. Record the outcome on the field data sheet.

7.3 Verify Automatic Closure

Pre-fill the test fixture with 0.25 multiplied by (5.0 gallons—minus the container's rated capacity) gallons of water as shown in the following equation:

$$\text{Pre - fill Volume} = 0.25 * (5 \text{ gallons} - \text{capacity in gallons})$$

Following the manufacturers instructions, carefully insert the spill-proof spout into the opening on top of the test fixture (see Figure 2) and dispense water until the

tip of the spout is immersed in water. Lift the container to engage the automatic closure feature and gently tap the spout against the opening of the test fixture to remove any water that may adhere to the exterior surface of the spout. Verify that the spout remains closed and sealed by observing the spout for any water leakage while still in the inverted position for 10 seconds. Return the system to the normal upright position and check for leaks and liquid retention while repositioning and for 10 seconds after repositioning. Record observations on the field data sheet.

Empty test fixture and repeat test procedure two more times in sequence without refilling the fuel container.

7.4 Pressurized Leak Check

Remove the spill-proof spout and modify the portable fuel container as detailed in figure 3. Fill the portable fuel container to its rated capacity with water and attach the spill-proof spout per manufacturer's instructions. Using a sufficient ballast, place the modified spill-proof system upright in a water bath large enough to completely cover the portable fuel container and at least six inches. Using a compressed air source, slowly pressurize the spill-proof system to 5.0 psig and record the pressure at which any leaks (i.e., bubbles) may appear. After reaching 5.0 psig, observe the system for any leaks for a period of five minutes. Leaks are determined through the evidence of any bubbles coming from the portable fuel container or spout. Record observations on the field data sheet.

8. QUALITY ASSURANCE / QUALITY CONTROL (QA/QC)

This section is reserved for future specification.

9. RECORDING DATA

Record data on a form similar to the one shown in Figure 1.

10. CALCULATING RESULTS

This section is reserved for future specifications.

11. ALTERNATIVE TEST PROCEDURES

Test procedures, other than specified above, shall only be used if prior written approval is obtained from the ARB Executive Officer. In order to secure the ARB Executive Officer's approval of an alternative test procedure, the applicant is responsible for demonstrating to the ARB Executive Officer's satisfaction that the alternative test procedure is equivalent to this test procedure.

Such approval shall be granted on a case-by-case basis only.

Documentation of any such approvals, demonstrations, and approvals shall be maintained by the ARB Executive Officer and shall be made available upon request.

12. REFERENCES

This section is reserved for future specification.

13. FIGURES

Figure 1. Field Data Sheet

Figure 2. Test Fixture

Figure 3. Elevated Pressure Test Setup

Figure 1

Field Data Sheet

Portable Fuel Container Compliance Tests

I.D. Number _____ Container Volume (gallons) _____

System Mfg. _____ Spout Model _____
Container Model _____

Initial Leak Check P F Tested By: _____ Test Date: _____

Automatic Closure Test

Tested By: _____ Test Date: _____

Automatic Closure Test Results (pass / fail)			Comments
Trial 1	Trial 2	Trial 3	

Elevated Pressure Test

Tested By: _____ Test Date: _____

Pressure Test Results				Comments
Start Time	Stop Time	Total (minutes)	Results (pass/fail)	

I.D. # of Container Used

Additional Comments:

Figure 2. Test Fixture

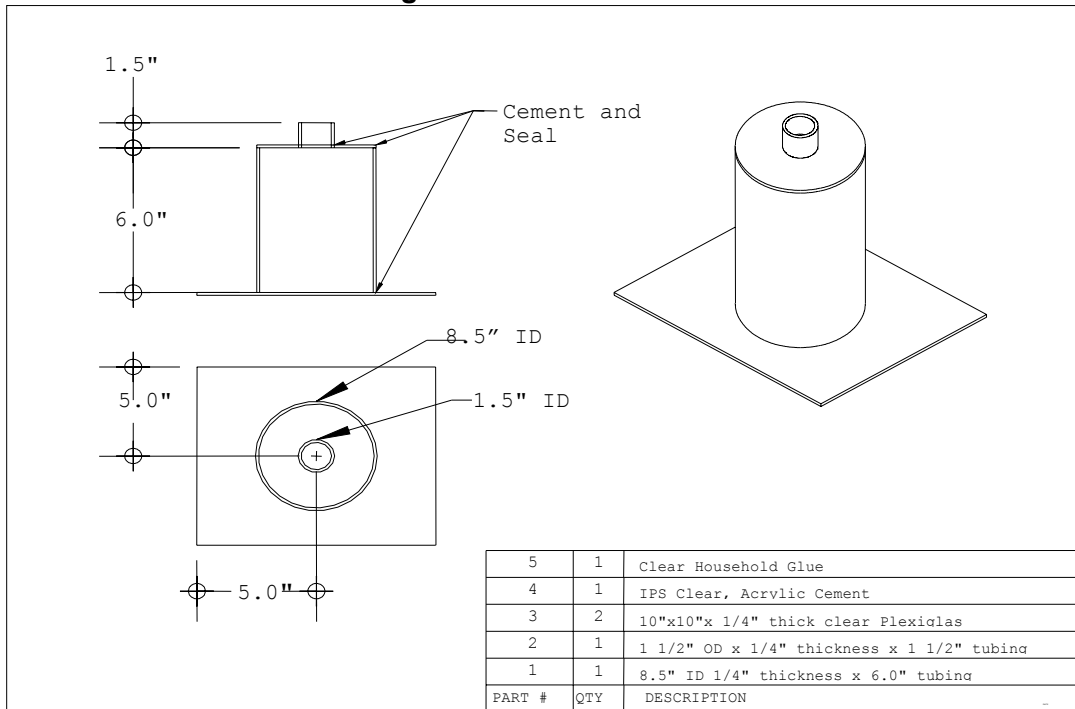

Figure 3. Pressurized Leak Check Assembly

