

**State of California
AIR RESOURCES BOARD**

Executive Order G-70-187

**Certification of the Healy Model 400 ORVR
Vapor Recovery System for Aboveground
Storage Tank Systems**

WHEREAS, the California Air Resources Board ("the Board" or "CARB") has established, pursuant to California Health and Safety Code sections 39600, 39601 and 41954, certification procedures for systems designed for the control of gasoline vapor emissions during motor vehicle fueling operations (Phase II vapor recovery systems) in its "CP-205 Certification Procedure for Vapor Recovery Systems of Novel Facilities" (the "Certification Procedures") as last amended March 17, 1999, incorporated by reference into Title 17, California Code of Regulations, Section 94015;

WHEREAS, the Board has established, pursuant to California Health and Safety Code sections 39600, 39601 and 41954, test procedures for determining the compliance of Phase II vapor recovery systems with emission standards in its "Determination of Efficiency of Phase II Vapor Recovery Systems of Novel Facilities", TP-205.2 ("the Test Procedures") as last amended March 17, 1999, incorporated by reference into Title 17, California Code of Regulations, Section 94015;

WHEREAS, James W. Healy of Healy Systems, Incorporated ("Healy") has requested certification of the Healy Model 400 ORVR Nozzle with central vacuum sources for previously certified integral aboveground storage tank systems pursuant to the Certification Procedures and Test Procedures;

WHEREAS, the Executive Officer has determined, pursuant to Section 3.1 of the Certification Procedures, that components used in installations of the Healy 400 ORVR System for aboveground storage tank systems must meet the same performance standards and specifications met during certification under CP-201, "Certification Procedure for Vapor Recovery Systems of Dispensing Facilities";

WHEREAS, the Healy Model 400 ORVR Vapor Recovery System (the vapor recovery system) has been evaluated pursuant to the Board's Certification Procedures;

WHEREAS, Section 7 of the Certification Procedures provides that the Executive Officer shall issue an order of certification if he or she determines that the vapor recovery system conforms to all of the requirements set forth in Section 1 through 6 of the Certification Procedures;

WHEREAS, the Executive Officer acknowledges the need for the introduction of vapor recovery systems that are compatible with, and efficient when refueling vehicles having an onboard refueling vapor recovery system (ORVR vehicles); and

WHEREAS, I, Michael P. Kenny, Air Resources Board Executive Officer, find that the Healy Model 400 ORVR Vapor Recovery System conforms with all the requirements set forth in the Certification

Procedures and results in a vapor recovery system which is at least 95 percent effective for attendant and/or self-serve use at gasoline service stations or remote locations when used in conjunction with a previously certified integral aboveground storage tank Phase I vapor recovery system and meeting the requirements contained in Exhibit 2 of this Order.

WHEREAS, Sections 3.4.1, 5.4 and 7 of CP-201 provide that the Executive Officer may condition the certification of any system;

NOW, THEREFORE, IT IS HEREBY ORDERED that Healy Model 400 ORVR System is certified to be at least 95 percent effective in attended and/or self-service mode when used with a previously certified single or split product integral aboveground storage tank Phase I vapor recovery system and which meets the requirements as specified in Exhibits 1 and 2. Fugitive emissions, which may occur when the aboveground storage tanks are under positive pressure have not been quantified and were not included in the calculation of system effectiveness. **Preliminary compatibility of this system with onboard vapor refueling vapor recovery (ORVR) systems has been determined. This system passed evaluation of refueling ORVR-equipped vehicles.** Exhibit 1 contains a list of the equipment certified for use with the Healy Model 400 ORVR System. Exhibit 2 contains installation and performance specifications for the system. Exhibit 3 contains a static pressure decay test for the Phase I system and vent piping. Exhibit 4 contains a static pressure decay test specifically for the Phase II piping network between the nozzle and the Healy Central Vacuum Unit. Exhibit 5 contains the Fillneck Vapor Pressure Regulation Fueling Test for the Healy Model 400 ORVR nozzle. Exhibit 6 contains the ten-gallon per minute maximum fueling rate compliance verification procedure.

IT IS FURTHER ORDERED that the following requirements are made a condition of certification. The Healy Model 400 ORVR System shall be installed only in facilities which are capable of demonstrating ongoing compliance with the vapor integrity requirements contained in Exhibit 3 (Static Pressure Decay Test), Exhibit 4 (Vapor Return Line Vacuum Integrity Test) and Exhibit 5 (Vapor Pressure Regulation Test). The owner or operator of the installation shall conduct, and pass, the specified tests no later than 60 calendar days after startup and at least once in each twelve month period. The test results shall be made available to the local air pollution control or air quality management district upon request within fifteen calendar days after the tests are conducted. Test results shall be submitted to the district in the format specified by the district.

IT IS FURTHER ORDERED that the Healy Model 400 ORVR System, as installed, shall comply with the procedures and performance standards the test installation was required to meet during certification testing. If, in the judgment of the Executive Officer, a significant fraction of the installations fails to meet the specifications of this certification, or if a significant portion of the vehicle population is found to have configurations which significantly impair the system's collection efficiency, the certification itself may be subject to modification, suspension or revocation.

IT IS FURTHER ORDERED that compliance with the certification requirements and rules and regulations of the Division of Measurement Standards of the Department of Food and Agriculture, the State Fire Marshal's Office, and the Division of Occupational Safety and Health of the Department of Industrial Relations are made a condition of this certification.

IT IS FURTHER ORDERED that the Healy Model 400 ORVR System shall, at a minimum, be operated in accordance with the manufacturer's recommended maintenance intervals and shall use the manufacturer's recommended operation and maintenance procedures as approved by CARB. Revisions to the manufacturers' manuals shall be approved by CARB. The Executive Officer may add or delete instructions from the manuals and distribute revised copies in accordance with CP-201.

IT IS FURTHER ORDERED that Healy Model 400 ORVR System installations shall have a CARB-certified System monitor as specified in Exhibit 2 except when the monthly throughput is less than 10,000 gallons.

IT IS FURTHER ORDERED that Healy Systems shall provide, to the station or facility owner, operator or designee, CARB-approved copies of the operation and maintenance manuals for the Healy Model 400 ORVR System. Healy Systems or a factory authorized representative, shall provide to the station manager or other responsible individual, instructions in the proper use of the Healy Model 400 ORVR System, its repair and maintenance schedules, and locations where system and/or component replacements can be readily obtained. Revisions to the manual are subject to approval by CARB. The Executive Officer may add or delete instructions from the manuals and distribute revised copies in accordance with CP-201.

IT IS FURTHER ORDERED that copies of this Executive Order and installation and maintenance manuals for the Healy Model 400 ORVR System shall be stored at the facility for service station type operations or at a central location for remote or unattended locations.

IT IS FURTHER ORDERED that Healy Systems shall warranty the Healy Model 400 ORVR System for at least one year, in writing, to the ultimate purchaser and each subsequent purchaser, that the vapor recovery system is designed, built and equipped so as to conform, at the time of original installation or sale, with the applicable regulations and is free from defects in materials and workmanship which would cause the vapor recovery system to fail to conform with applicable regulations. Healy Systems shall provide copies of the manufacturer's warranty for the Healy Model 400 ORVR System, to the station manager, owner or operator. Hoses, nozzles and breakaway couplings shall be warranted to the ultimate purchaser as specified above for at least one year, or for the expected useful life, whichever is longer.

IT IS FURTHER ORDERED that any alteration of the equipment, parts, design, or operation of the system certified hereby is prohibited unless such alteration has been approved by the Executive Officer or his or her designee. Any unapproved alteration shall void the certification for the specific installation where such alteration occurred.

Executed at Sacramento, California, this _____ day of _____, 1999.

signed September 13, 1999
Michael P. Kenny
Executive Officer

Executive Order G-70-187

**Exhibit 1
Healy Model 400 ORVR Nozzle System
Equipment List**

<u>Component</u>	<u>Manufacturer/Model</u>	<u>State Fire Marshal Identification Number</u>
Nozzle	Model 400 ORVR (w/vapor valve) (See Exhibit 2, Figure 1)	005:027:023
Vapor Pumps (Collection Unit)	9000 Mini-Jet Pump (non-electric gasoline-driven pump) 9000-01 without siphon 9000-02 with siphon (See Exhibit 2, Figures 2A - 2D)	005:027:009
	Thomas Industries/Franklin Electric VP-500 Vane Pump (1/2 hp) (See Exhibit 2, Figure 3)	005:027:017
	100 Jet Pump (2 each per nozzle) (non-electric gasoline driven pump) (See Exhibit 2, Figures 4A and 4B)	005:024:004
Vapor Check Valve	Healy Model 9466	005:027:024
System Monitor Pressure Switch Vent Sensor P/V Valve	System Monitor Model 6280 Pressure Switch Model 9800-1 Vent Sensor Model 6275 Healy P/V Valve HPV 1.5	005:027:022
Inverted Coaxial Hoses	Healy Model 75B (3/4" I. D.)	005:027:003
	Healy Model 88B (7/8" I. D.)	005:027:004 005:027:005
	OR Any inverted coaxial hose CARB-certified for use with the Healy Model 400 ORVR system.	
Hose Adapters	Healy Model series CX6- followed by suffix letter(s) "G", "D", "U", "VV1", "VV2", "VV3", "TCSVV", "DWVV", "VV1A", "VV2A", "VV3A", "TCSVVA", "DWVVA"	005:027:019
	Note: The "A" indicates that no valve is provided in the fitting because the vapor valve is integrated into the nozzle.	
	"G" Gilbarco Dispensers "D" Dresser/Wayne Dispensers "U" Universal Dispensers "VV1" Dispensers-Lowboy (with vapor valve) "VV2" Vapor Ready Balance Type "VV3" Universal Dispensers "TCSVV" Tokheim Dispensers	

Breakaway Couplings	"DWVV" Dresser/Wayne Dispensers	
	Healy Model 8701VV	005:027:016
	Healy Model 8701	005:027:016
	w/ 715V Upgrade Kit	
Pressure/Vacuum Valves	Pressure/Vacuum relief valves shall be certified and have the following pressure and vacuum settings, in inches water column (wc):	
	<u>Pressure</u> : three plus or minus one-half inches (3.0" \pm 0.5")	
	<u>Vacuum</u> : eight plus or minus two inches (8 \pm 2")	
Certified Valves	OPW 523LP, 523LPS	005:008:051
	OPW 523V	005:008:058
	Hazlett H-PVB-1 Gold label	005:017:004
	Husky 4620 P/V	005:021:015
	Morrison Brothers 749CRB0600 AV	005:041:001
	EBW Models 802-309, 802-308	005:034:006
	OR Any CARB-certified P/V valve which meets the required pressure/vacuum specifications.	
Flow Control Units	Healy Model 1301 (for 1 1/4" straight fitting) or	005:027:020
For Fueling Rate	Healy Model 1302 (for M34 fittings)	

Executive Order G-70-187

Exhibit 2

Specifications for the Healy Model 400 ORVR Vapor Recovery System for Aboveground Storage Tank Systems

1 Nozzle

- 1.1 The Healy Model 400 ORVR nozzle shall have an operating pressure range at the nozzle boot/fillpipe interface of -1/4" to 0" water column (wc) within an accuracy of +/-1/4" wc (total allowable range is -1/2" to +1/4" wc). Pressure readings shall be taken using a certified test system or non-ORVR equipped vehicles pursuant to Exhibit 5, "Fillneck Vapor Pressure Regulation Fueling Test".
- 1.2 Nozzles shall be 100 percent performance checked at the factory including checks of all shutoff mechanisms and the integrity of the vapor path. The leak rate for the nozzle vapor path shall not exceed the following:
 - 0.038 CFH at a pressure of two inches water column (2" WC); and
 - 0.005 CFH at a vacuum of eighty-three inches water column (approximately 3 psi).The nozzle shall meet these specifications for the duration of the warranty.
- 1.3 The nozzle boot shall be maintained in good condition and shall be replaced whenever the concatenation of all tears (including rips, slits, cracks and etc.) exceeds 1/2" in length. A nozzle with a boot with tears exceeding 1/2" in length is defined as a equipment defect which substantially impairs the effectiveness of the system in accordance with Health and Safety Code Section 41960.2(c) and is subject to district enforcement action in accordance with Health and Safety Code Section 41960.2(d).

2 Inverted Coaxial Hoses

- 2.1 The maximum length of any hose shall not exceed 13 feet.
- 2.2 The length of hose which may be in contact with the top or side of the island and/or ground when the nozzle is properly mounted on the dispenser is limited to six inches (6") per refueling point.
- 2.3 A certified swivel shall be installed at the nozzle end of the coaxial hose. A certified swivel may be installed on the dispenser end at the option of the station owner or authorized representative.

3 Inverted Coaxial Hose Adapters

Inverted coaxial hose adapters shall be 100 percent performance checked at the factory to verify that they are 100% vapor tight. Adapters shall be maintained 100 percent vapor tight.

4 Breakaway Couplings

Breakaway couplings shall be installed. Only certified breakaways with a valve that closes the vapor path when separated may be used.

5 Central Vacuum Unit

- 5.1** The Healy Model 400 ORVR system shall operate with at least one of the central vacuum units (pumps) specified in Exhibit 1 (see Figures 2A-2D and Figure 3). Each central vacuum pump shall be 100 percent performance checked at the factory including verification that the pump, when installed in the system, can be adjusted such that the vapor recovery system performance will operate within the range specified in Exhibit 2 of this executive order. The vapor recovery system vacuum shall be checked and the central vacuum unit adjusted (if necessary) after installation and before commencing operation of the system to insure that the system vacuum operates within a dynamic range from 65" wc to 85" wc.
- 5.2** No dispensing shall be allowed when the central vacuum unit is disabled for maintenance or for any other reason. Dispensing of gasoline when the central vacuum unit is disabled is defined as a equipment defect which substantially impairs the effectiveness of the system in accordance with Health and Safety Code Section 41960.2(c) and is subject to district enforcement action in accordance with Health and Safety Code Section 41960.2(d).
- 5.3** The system shall be equipped with a vacuum gauge (0"- 100" wc) in order to manually monitor the system vacuum. The gauge shall be installed on the inlet side of the central vacuum unit (see Figures 2A, 2C, 3 and 4A) by means of a "tee" and two ball valves with (1) one end of the "tee" connected directly to the gauge, (2) the second end of the "tee" connected to the first ball valve which is connected to the vacuum line and (3) the middle of the "tee" connected to the second ball valve which opens to atmosphere. Both valves shall be closed and the atmospheric port capped except when the gauge is in use. The atmospheric valve may be opened with the vacuum valve closed in order to check the gauge "zero"; a second gauge may also be connected to the atmospheric port with the ball valve to the system vacuum open to check the gauge accuracy.
- 5.4** The system shall operate within a vacuum range from 65" to 85" wc. This vacuum range shall be determined by observing the mechanical gauge as required by Section 5.3.
- 5.5** The maximum number of fueling points that can be supported by each central vacuum unit is listed below in Table 1. This number is based on an in use factor of (50%) and a demonstration of the maximum number of fueling points which can be operated simultaneously while the nozzles maintain vacuum levels within the required operating range. The local district may require a demonstration of nozzle performance with the maximum number of simultaneous fueling points in operation as specified in Exhibit 5, Fillneck Vapor Pressure Regulation Fueling Test.

Table 1
Central Vacuum Unit – Maximum and Simultaneous Number of Fueling Points

Central Vacuum Unit	Maximum Number Of Fueling Points	Maximum Number of Simultaneous Fueling Points
Healy 9000 Mini-Jet Pump	8	4
Thomas Industries / Franklin Electric VP500 Vane Pump	10	5
Healy Model 100 Jet Pump	2	1

(2 each per operating nozzle)		
--------------------------------	--	--

To increase the maximum number of fueling points in a gasoline dispensing facility, two or more central vacuum units may be installed in parallel to maintain the necessary vacuum for the system as per CARB approved manufacturer's instructions. The local district may require verification that the system can operate within the specified vacuum range with the maximum number of nozzles which may be used simultaneously as specified in Exhibit 5, Fillneck Vapor Pressure Regulation Fueling Test.

- 5.6** The system shall achieve the minimum operating vacuum of 65" wc within fifteen seconds after the system is energized for a dispensing episode (time required to evacuate the Phase II piping).
- a. A failure to achieve the required initial vacuum for three consecutive dispensing episodes is defined as a equipment defect which substantially impairs the effectiveness of the system in accordance with Health and Safety Code Section 41960.2(c) and is subject to district enforcement action in accordance with Health and Safety Code Section 41960.2(d).
 - b. A failure to achieve the required initial vacuum within a one (1) hour period for any single dispensing episode is defined as a equipment defect which substantially impairs the effectiveness of the system in accordance with Health and Safety Code Section 41960.2(c) and is subject to district enforcement action in accordance with Health and Safety Code Section 41960.2(d).
- 5.7** After the initial minimum vacuum has been reached, the system shall operate within a vacuum range from 65" to 85" wc throughout the dispensing episode. A vacuum level below 60" wc for more than three seconds after the system has reached 65" wc, measured while dispensing is occurring, is defined as a equipment defect which substantially impairs the effectiveness of the system in accordance with Health and Safety Code Section 41960.2(c) and is subject to district enforcement action in accordance with Health and Safety Code Section 41960.2(d). A vacuum level below 65" wc but greater than or equal to 60" wc for more than three seconds after the system has reached 65" wc, measured while dispensing is occurring, indicates that the system is not in good working order, but is not a defect specified pursuant to Health and Safety Code section 41960.2(c), and is subject to district enforcement action including action under Health and Safety Code Section 41960.2(e).
- 5.8** A vacuum level above 90" wc measured while dispensing is occurring is defined as a equipment defect which substantially impairs the effectiveness of the system in accordance with Health and Safety Code Section 41960.2(c) and is subject to district enforcement action in accordance with Health and Safety Code Section 41960.2(d). A vacuum level above 85" wc but less than or equal to 90" wc measured while dispensing is occurring indicates that the system is not in good working order, but is not a defect specified pursuant to Health and Safety Code section 41960.2(c), and is subject to district enforcement action including action under Health and Safety Code Section 41960.2(e).
- 5.9** A non-restrictive ball valve with a nominal size the same as the vapor return line shall be installed in the vapor return line such that the vacuum lines can be isolated from the aboveground storage tanks for the purpose of conducting the "Vacuum Return Line Integrity Test" as specified in Exhibit 4. The valve shall remain open at all times except when the test is being conducted Product dispensing when this valve is closed is defined as a equipment defect which substantially impairs the effectiveness of the system in accordance with Health and Safety Code Section 41960.2(c) and is

subject to district enforcement action in accordance with Health and Safety Code Section 41960.2(d).

6 **9466 Check Valve**

The 9466 Check Valve is a required system component and shall not be removed or bypassed during operation or testing of the system.

7 **System Monitor**

The Healy Model 400 ORVR system shall have a CARB approved system monitor unless exempted by this executive order.

8 **System Monitor Vacuum Sensor**

8.1 The monitor shall be powered at all times and have a “power” light indicator. The vacuum monitor portion shall have three system indicator lights. One light shall indicate that the vapor recovery system “motor” (VP500 vane pump, 100 jet pump(s) or 9000 mini-jet pump) has power. The other two lights shall indicate the system is operating within either “run” or “low” vacuum levels.

8.2 The monitor shall flash the “low” vacuum indicator (red LED) whenever the system vacuum level is below sixty-five inches water column (65" wc) as sensed by the System Monitor Pressure Switch during dispensing episodes. The “run” vacuum light (green LED) shall light when the vacuum is 65" wc or higher as sensed by the System Monitor Pressure Switch during dispensing episodes.

8.3 The monitor shall sound an alarm and record a system vacuum failure whenever the system fails to achieve the minimum operating vacuum of 65" wc within fifteen seconds after the system is energized for a dispensing episode for three consecutive dispensing episodes.

8.4 The monitor shall sound an alarm, continuously flash the “low” vacuum red LED and record a system vacuum failure whenever the vacuum level, as sensed by the System Monitor Pressure Switch during dispensing episodes, is less than 65" wc for more than a total of one (1) hour in any calendar day.

8.5 The system monitor shall be located in an area that is audible to station personnel while at their common workplace.

8.6 The pressure switch shall be installed at the inlet to the central vacuum unit as shown in Figures 2A, 2C and 3.

9 **System Monitor Vent Sensor**

9.1 The vent-sensing portion of the system monitor shall have two lights to indicate “venting” and “excess venting”. The “venting” light shall be set to light when venting is occurring. The “excess venting” light will be illuminated and the alarm will sound after a total accumulated time of ten hours of venting has been recorded within any calendar day.

9.2 The System Monitor shall, at a minimum, create a permanent record of system date and times of venting and excess venting.

10 Log Requirements

- 10.1** The Monitor shall cause a continuous audible alarm as specified in Sections 8.4, 8.7 and 9.1. The alarm may be silenced for a four hour period with a reset button but shall resound if the condition which caused the alarm is still present. The station owner/operator shall call for maintenance within 24 hours of the initial alarm sounding and shall maintain a "Monitor Maintenance Log Sheet" (see Figure 6) of all alarm events and corresponding maintenance actions. This log shall be kept on site at all times for service station type operations and at a central location for remote or unattended operations.
- 10.2** The owner/operator of service station type systems shall conduct a physical inspection of the equipment on a daily basis and manually monitor the system vacuum levels at the system vacuum gauge on a once per day basis during a dispensing episode to determine proper operation of the system. The inspection results and vacuum observations shall be recorded in a System Log to be kept on site at all times for service station type operations and at a central location for remote or unattended operations.

11 Phase II Vapor Recovery System

- 11.1** Operation of the Phase II system shall not cause venting through the system monitor vent in excess of ten (10) hours in any calendar day. Any venting through the system monitor vent in excess of ten (10) hours in any calendar day which is not attributable to a Phase I fuel delivery is subject to district enforcement action in accordance with Health and Safety Code Section 41960.2(e). Venting through the system monitor vent may be attributed to a Phase I delivery for the duration of the delivery and for a maximum one (1) period following the delivery. The station owner / operator will record events of venting which may be attributed to a Phase I fuel delivery in the System Log. Venting through the 3" pressure setting relief vent is defined as a equipment defect which substantially impairs the effectiveness of the system in accordance with Health and Safety Code Section 41960.2(c) and is subject to district enforcement action in accordance with Health and Safety Code Section 41960.2(d).
- 11.2** The minimum nominal pipe size of the Phase II plumbing shall be 2" up to the riser to the aboveground storage tank where the minimum nominal pipe size shall be 1". This requirement does not apply to self-contained dispenser pump systems as shown in Figure 4A.
- 11.3** The dispenser-to-riser connection shall be installed so that any liquid in the lines will drain toward the Phase II line low point. The internal diameter of the connector, including all fittings, shall not be less than five-eighths inch (5/8") for new factory equipped dispensers. The Healy Model series Z0XXX vapor recovery retrofit kits (which consist of two 0.5" OD copper tube and flare fittings to connect all hose outlet fittings on one side of the dispenser to a 1/2" pipe running vertically from the canopy to the base of the dispenser where 0.5" OD copper tubing and flare fittings connect to the underground vapor return riser) may be used on existing dispensers. This piping configuration is required on each side of the dispenser.
- 11.4** All vapor return lines shall have a slope sufficient to prevent a liquid blockage when used in conjunction with a low point condensate trap or knockout pot.

- 11.5** A condensate trap or knockout pot with an automatic liquid removal system shall be installed at the low point in the vapor return piping (see Figures 2B, 2D and 4D).
- 11.6** All exposed Phase II piping shall be painted white or off-white (with any color base) provided the reflectivity of the paint is 75 percent or better. Reflectivity shall be determined by visual comparison of the paint with paint color cards obtained from a paint manufacturer who uses the “Master Pallet Notation” to specify the paint color (i.e. 58YY 88/180 where the number in italics is the paint reflectivity). The appropriate color card shall be available at the facility for service station type operations or at a central location for remote or unattended locations.

12 Phase I System

- 12.1** The Phase I system shall be a CARB-certified system which is in good working order and which demonstrates compliance with the static pressure decay test criteria contained in Exhibit 3.
- 12.2** Spill containment boxes (when present) that have drain valves shall demonstrate compliance with the static pressure decay criteria with the drain valves installed as in normal operation.
- 12.3** The Phase I vapor recovery system shall be operated during product deliveries with no less than one vapor return hose connected for each product being delivered
- 12.4** All Phase I adapters, fittings and connections shall be maintained vapor tight as defined in CARB Source Test Methods Volume 2, Vapor Recovery Definitions, D-200.
- 12.5** The installation of the tank and associated piping and other equipment not specifically listed as certified Phase I equipment in CARB executive orders shall comply with the requirements of local fire officials with jurisdiction where the system is installed.

13 Dispensing Rate

The dispensing rate for installations of the Healy Model 400 ORVR System shall not exceed ten (10.0) gallons per minute for any nozzle. The dispensing rate shall be verified as specified in Exhibit 6, “Ten Gallon Per Minute Limitation Compliance Verification Procedure”.

**Executive Order G-70-187
Exhibit 2
Figure 1**

Healy 400 ORVR Nozzle

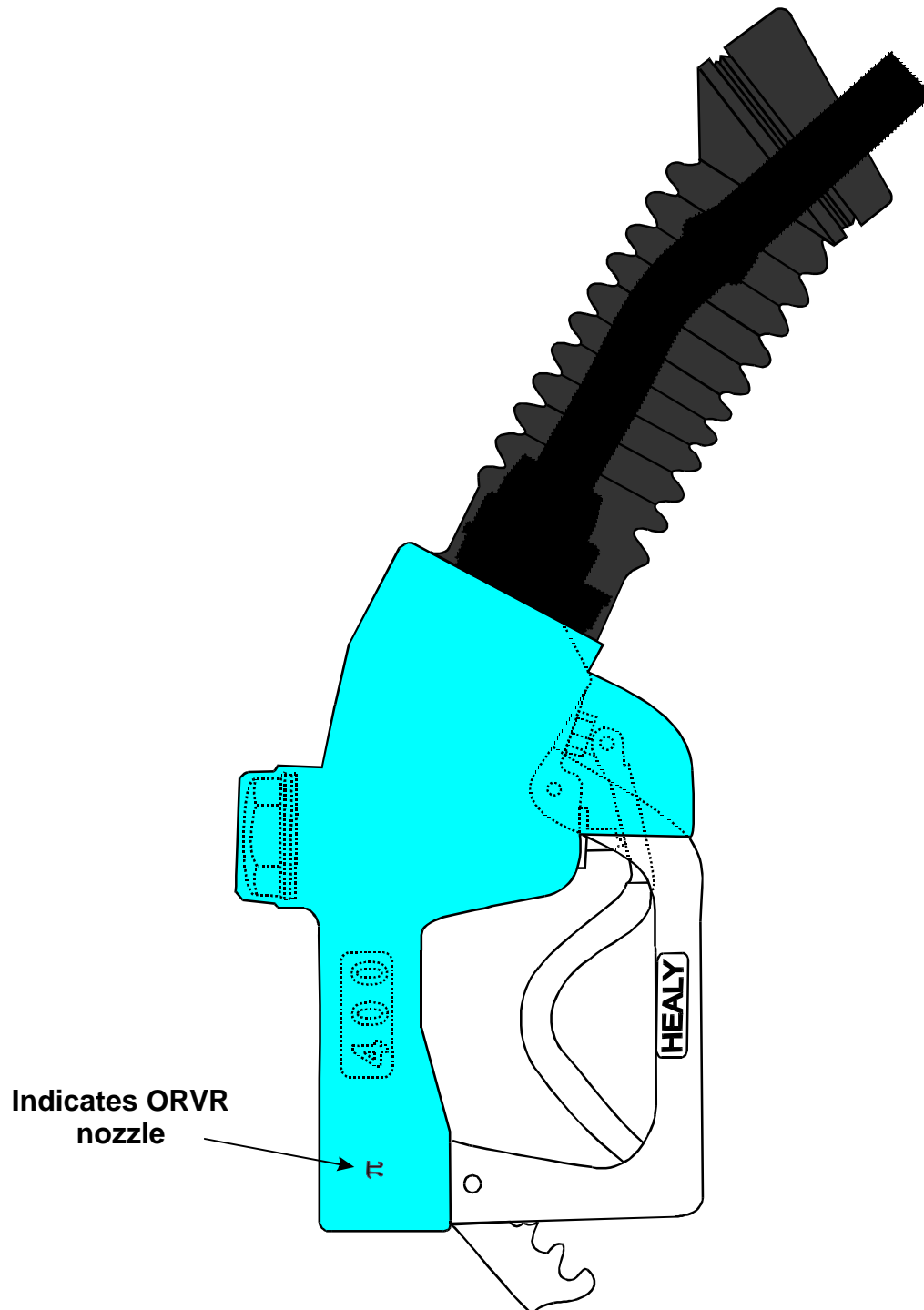

**Executive Order G-70-187
Exhibit 2
Figure 2A**

**TYPICAL ABOVEGROUND TANK
INSTALLATION WITH A 9000-01 MINI-JET**

See Note Below

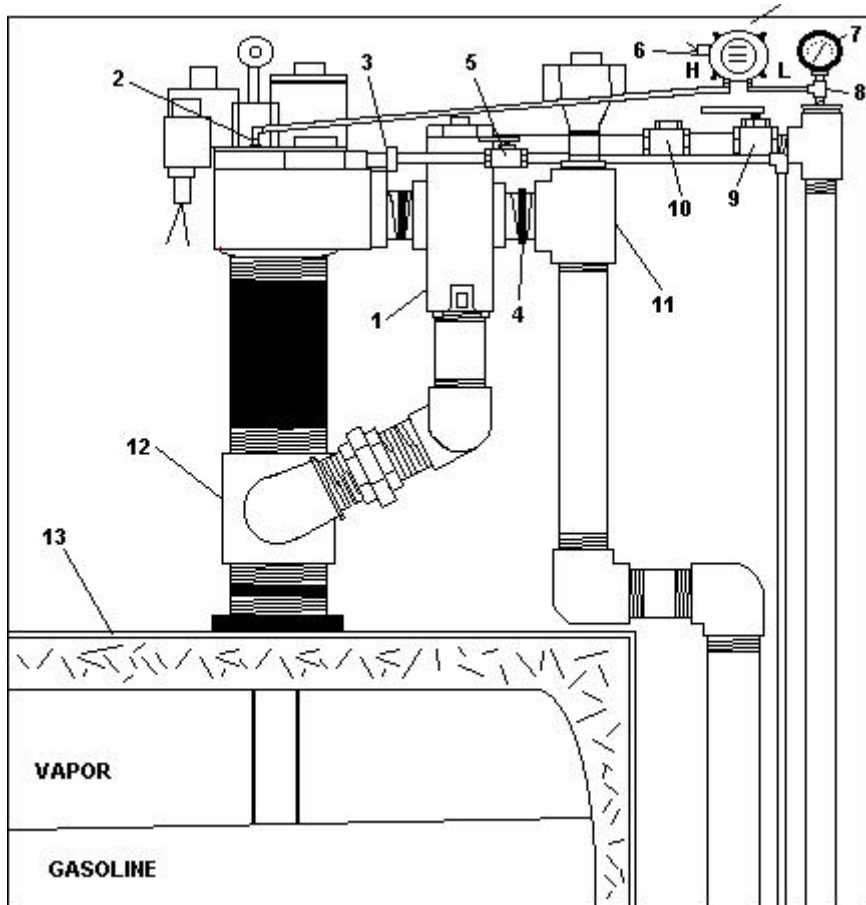

1. 9000-1 Healy Mini-Jet
2. 1/4" Tank Test Port
3. Siphon Valve, Red Jacket
4. Universal Check Valve #212BPR (or equivalent)
5. 1/4" Ball Valve, UL Listed
6. #9800-1 Pressure Switch, Healy
7. Vacuum Gauge, 0-100" WC
8. 1/4" TEE for Vacuum Gauge Port
9. 1" Ball Valve, UL Listed
10. Condensate Drain Check Valve #9466, Healy Systems
11. Leak Detector TEE Housing Red Jacket
12. 4"x2" Reducing TEE
13. Aboveground Vaulted Tank

*See executive order for system monitor requirements

**Executive Order G-70-187
Exhibit 2
Figure 2B**

**TYPICAL ABOVEGROUND TANK
INSTALLATION WITH A 9000-01 MINI-JET**

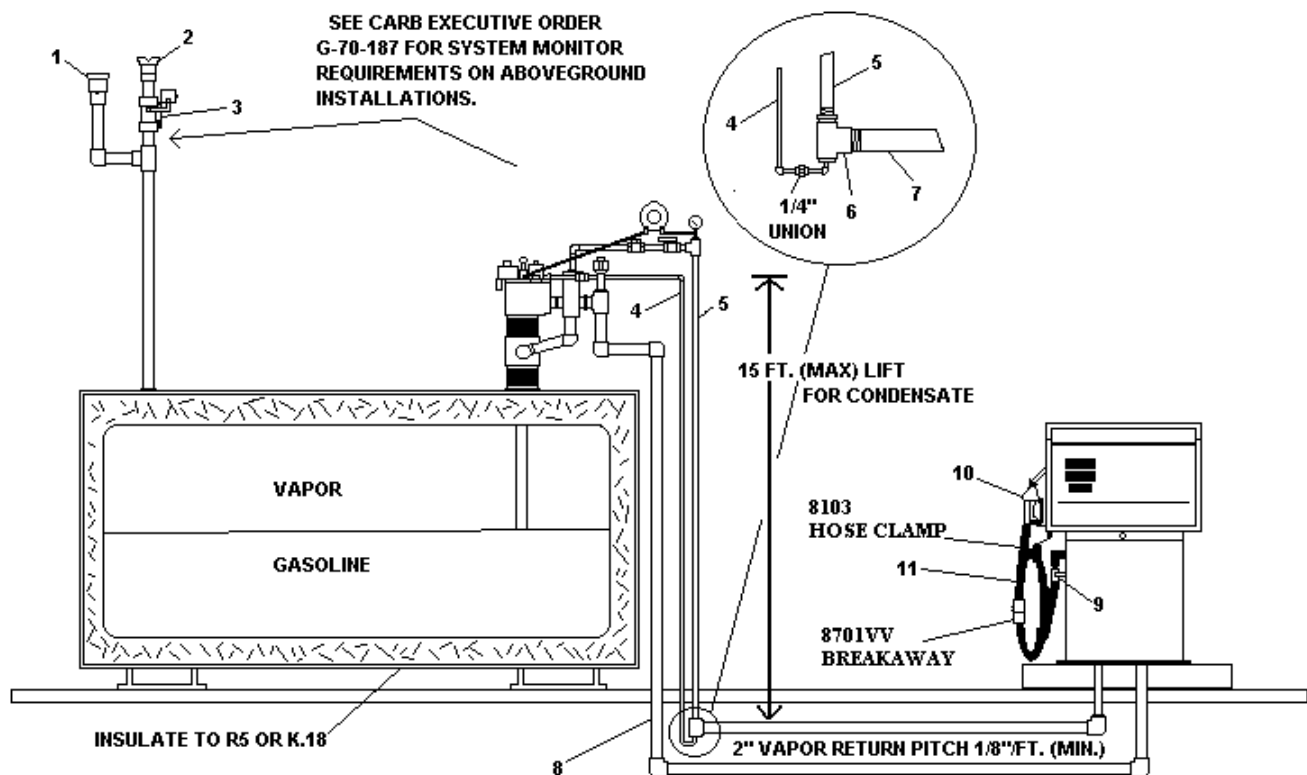

1. +3"wc, - 8"wc P/V Vent Valve, Healy Part #HPVV
2. +1.5"wc Pressure Vent Valve, Healy Part # HPV1.5
3. Vent Sensor Assembly, Healy Part # 6275
4. 1/4" Condensate Line
5. 1" Vapor Return Line

6. 2" TEE
7. 2" Vapor Return Line
8. 2" Product Line
9. Vapor Adapter, Healy Part # CX6-VV1A
10. Nozzle, Healy # 400 ORVR
11. Coaxial Hose Assembly, Healy Series #75B
with Hose Clamp & Breakaway

**Executive Order G-70-187
Exhibit 2
Figure 2C**

**TYPICAL ABOVEGROUND TANK
INSTALLATION WITH A 9000-02 MINI-JET**

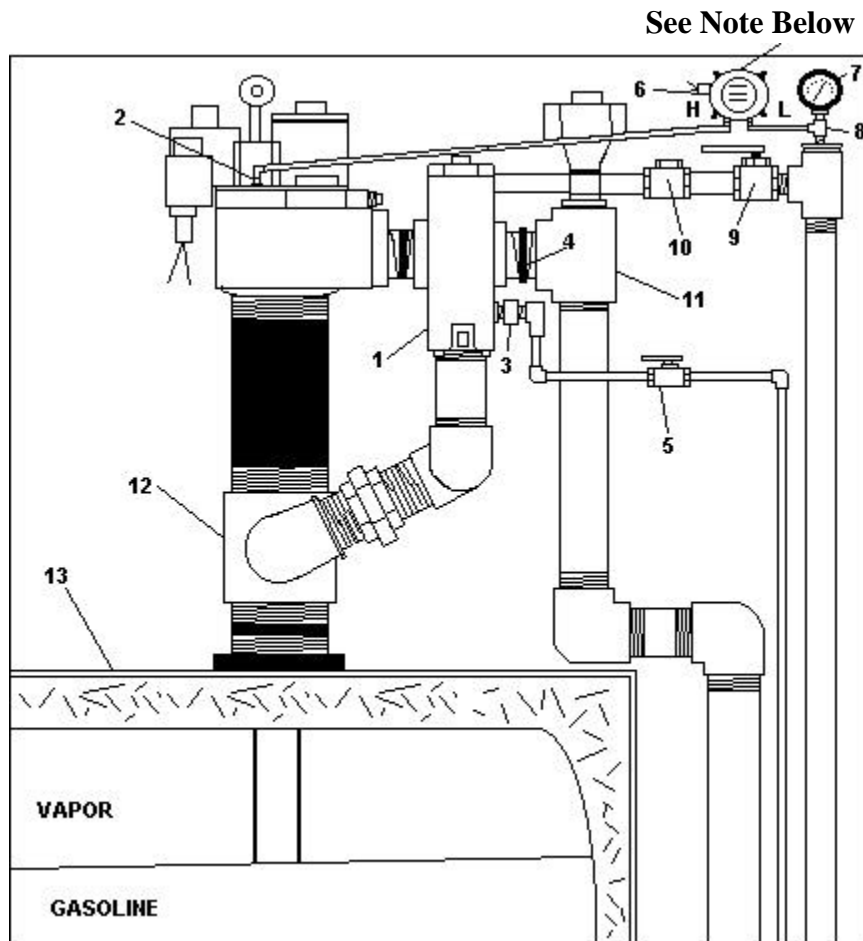

1. 9000-1 Healy Mini-Jet
2. 1/4" Tank Test Port
3. Siphon Valve, Red Jacket
4. Universal Check Valve #212BPR (or equivalent)
5. 1/4" Ball Valve, UL Listed
6. #9800-1 Pressure Switch, Healy
7. Vacuum Gauge, 0-100" WC
8. 1/4" TEE for Vacuum Gauge Port
9. 1" Ball Valve, UL Listed
10. Condensate Drain Check Valve #9466, Healy Systems
11. Leak Detector TEE Housing Red Jacket
12. 4"x2" Reducing TEE
13. Aboveground Vaulted Tank

*See executive order for system monitor requirements

Executive Order G-70-187
Exhibit 2
Figure 2D

TYPICAL ABOVEGROUND TANK
INSTALLATION WITH A 9000-02 MINI-JET

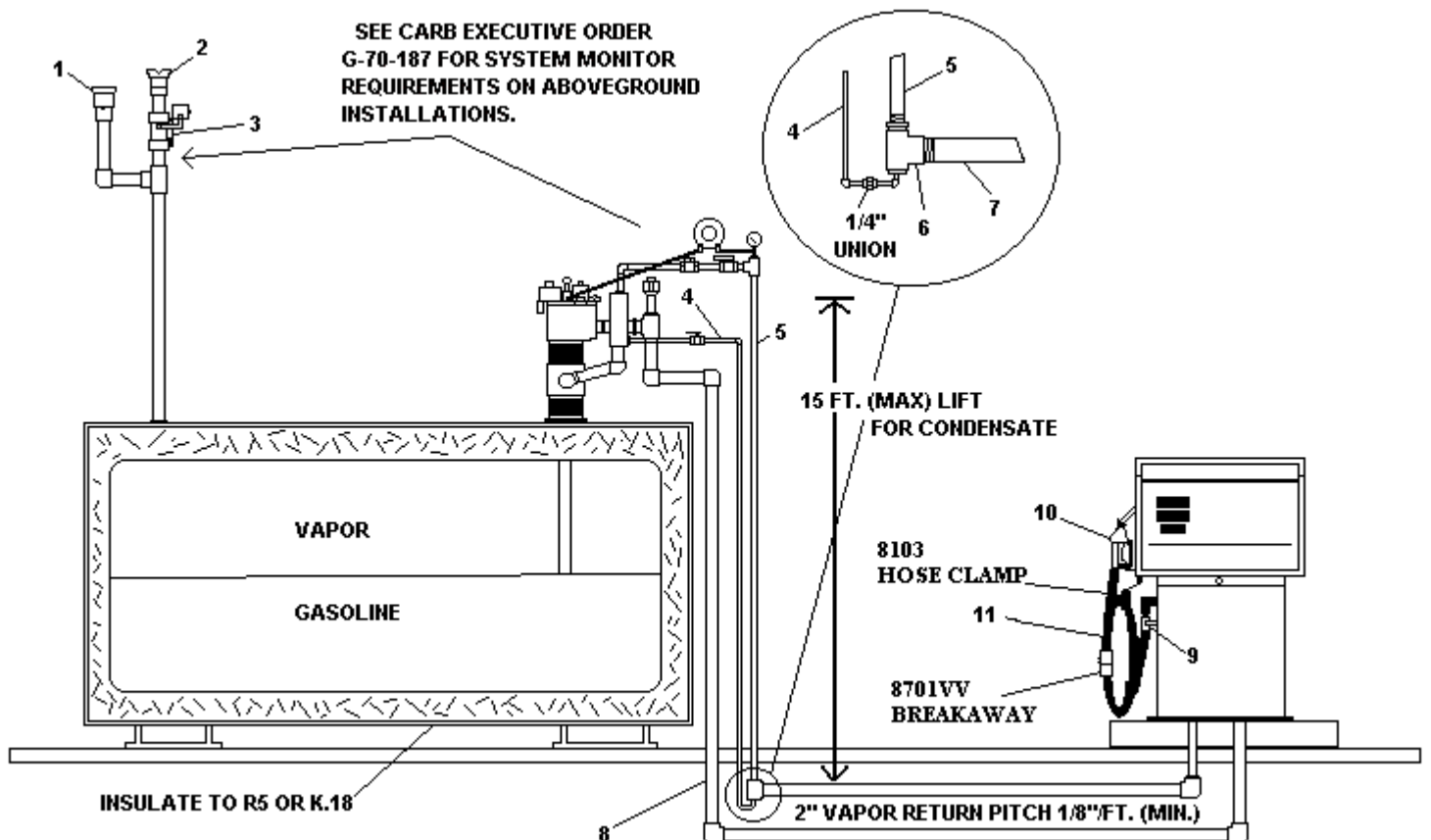

- | | |
|---|--|
| 1. +3"wc, - 8"wc P/V Vent Valve, Healy Part #HPVV | 6. 2" TEE |
| 2. +1.5"wc Pressure Vent Valve, Healy Part # HPV1.5 | 7. 2" Vapor Return Line |
| 3. Vent Sensor Assembly, Healy Part # 6275 | 8. 2" Product Line |
| 4. 1/4" Condensate Line | 9. Vapor Adapter, Healy Part # CX6-VV1A |
| 5. 1" Vapor Return Line | 10. Nozzle, Healy # 400ORVR |
| | 11. Coaxial Hose Assembly, Healy Series #75B with Hose Clamp & Breakaway |

**Executive Order G-70-187
Exhibit 2
Figure 3**

**TYPICAL ABOVEGROUND TANK
INSTALLATION WITH A VP500 VANE PUMP**

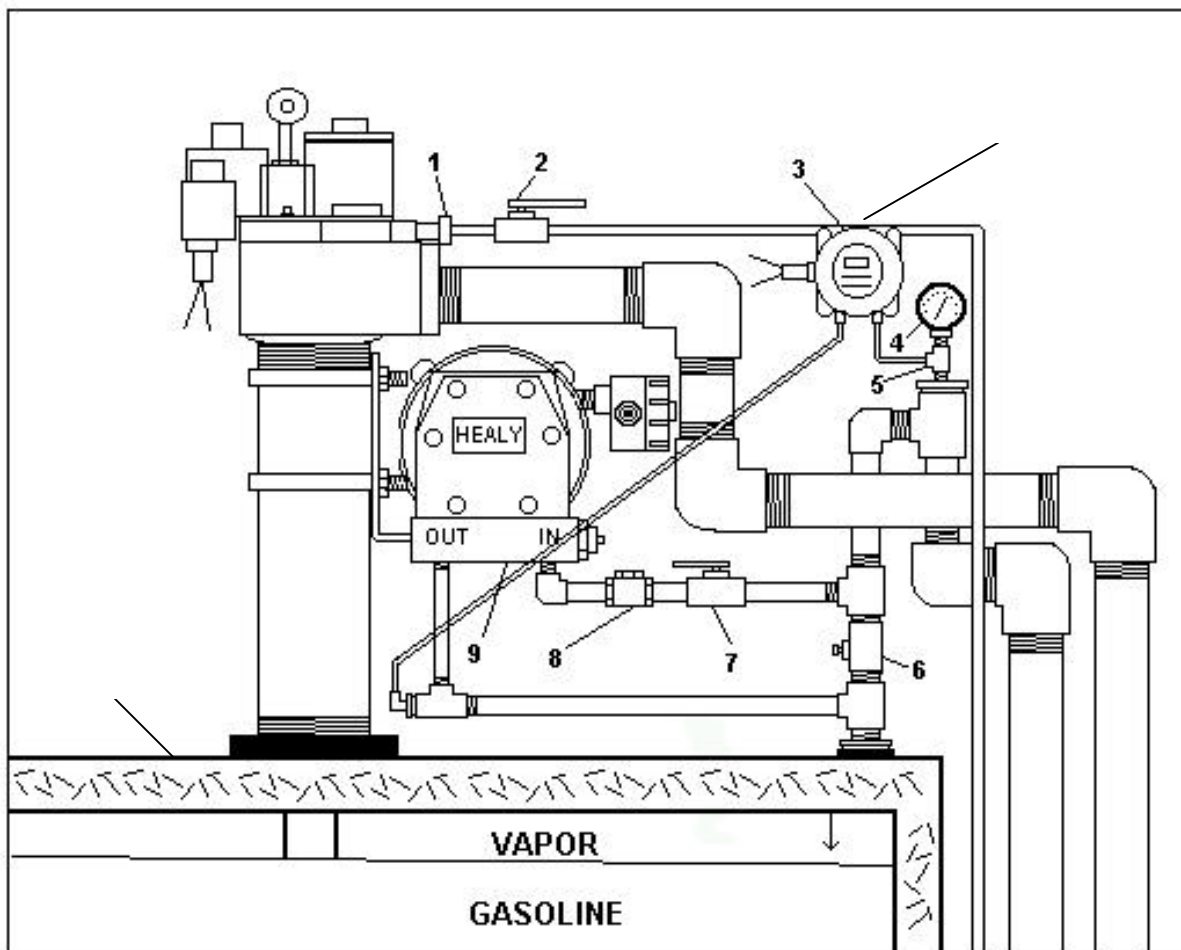

- | | |
|---|--|
| 1. Syphon Check Valve, Red Jacket | 2. 1/4" Ball Valve, UL Listed |
| 3. #9800-1 Pressure Switch, Healy | 4. W.C. Vacuum Gage 0" to 100" |
| 5. 1/4" TEE | 6. 1" Ball Valve, UL Listed (USUALLY CLOSED,
OPEN FOR TESTING ONLY) |
| 7. 1" Ball Valve, U. L. Listed | 9. VP500 Central Vacuum Vane Pump, Healy |
| 8. #9466 Back-Pressure Check Valve, Healy | |
| 10. Aboveground Vaulted Tank | |

- SEE CARB EXECUTIVE ORDER G-70-187 FOR SYSTEM MONITOR REQUIREMENTS ON ABOVEGROUND TANK INSTALLATIONS

**Executive Order G-70-187
Exhibit 2
Figure 4A**

**TYPICAL ABOVEGROUND TANK
INSTALLATION WITH A 100 JET PUMP
(SELF-CONTAINED PUMP)**

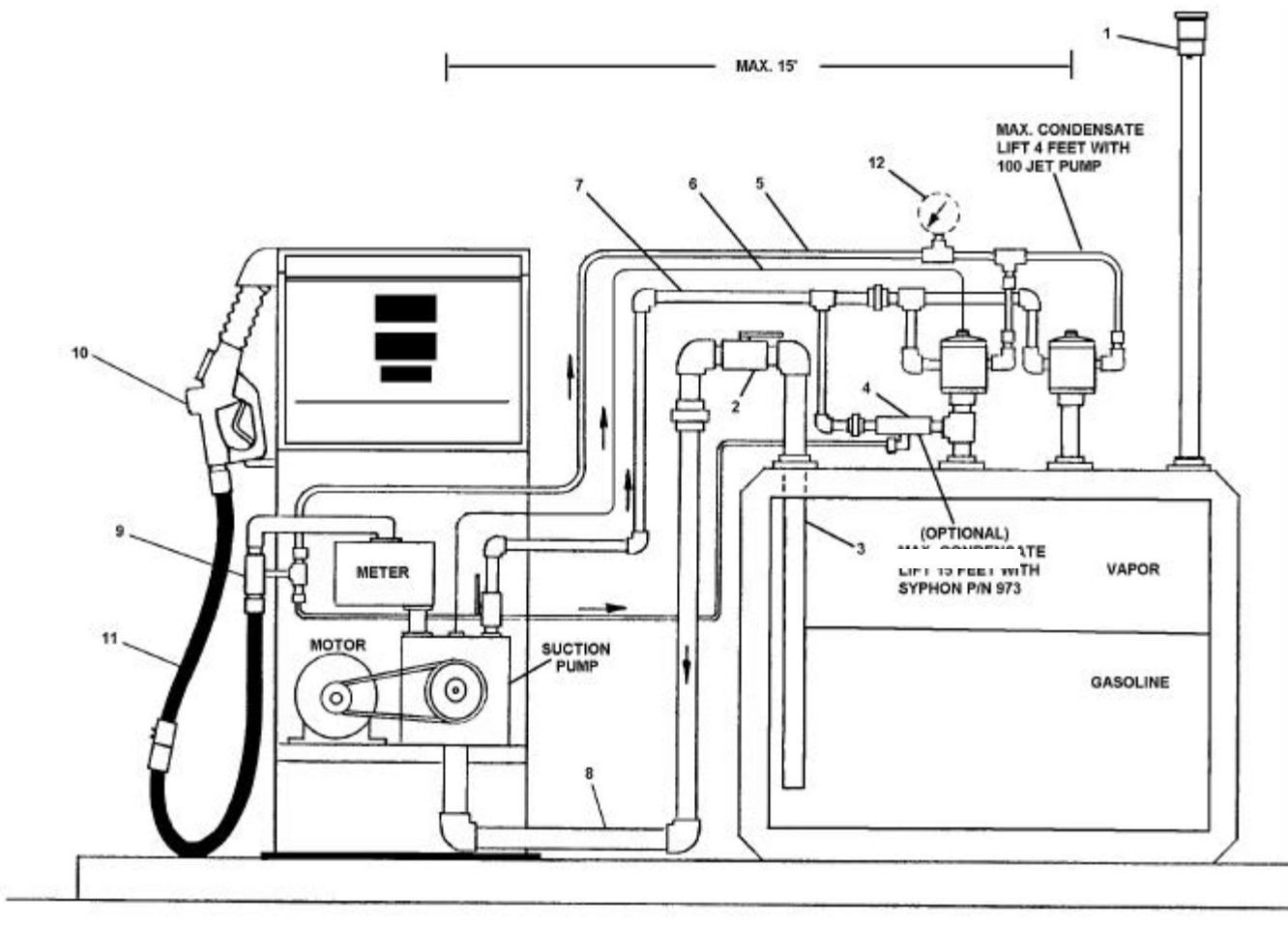

- | | |
|--|---|
| <ol style="list-style-type: none"> 1. +3" wc, - 8" wc P/V Vent Valve, Healy Part # HPVV 2. 1½" Ball Valve 3. 1½" Suction Riser 4. #973 Siphon Valve Assembly 5. ½" Vapor Return Line 6. ¼" Air Eliminator Bleed Line | <ol style="list-style-type: none"> 7. ½" Product Supply Line 8. 2" Product Line 9. Vapor Adapter, Healy Part # CX6-VV1A 10. Nozzle, Healy # 400 ORVR 11. Coaxial Hose Assembly, Healy Series #75B with Hose Clamp & Breakaway 12. 0" - 100" wc Vacuum Gauge |
|--|---|

NOTE: This Illustration is for a single hose installation. Two 100 Jet Pumps are required for each hose.

**Executive Order G-70-187
Exhibit 2
Figure 4B**

TYPICAL ABOVEGROUND TANK INSTALLATION WITH A 100 JET PUMP

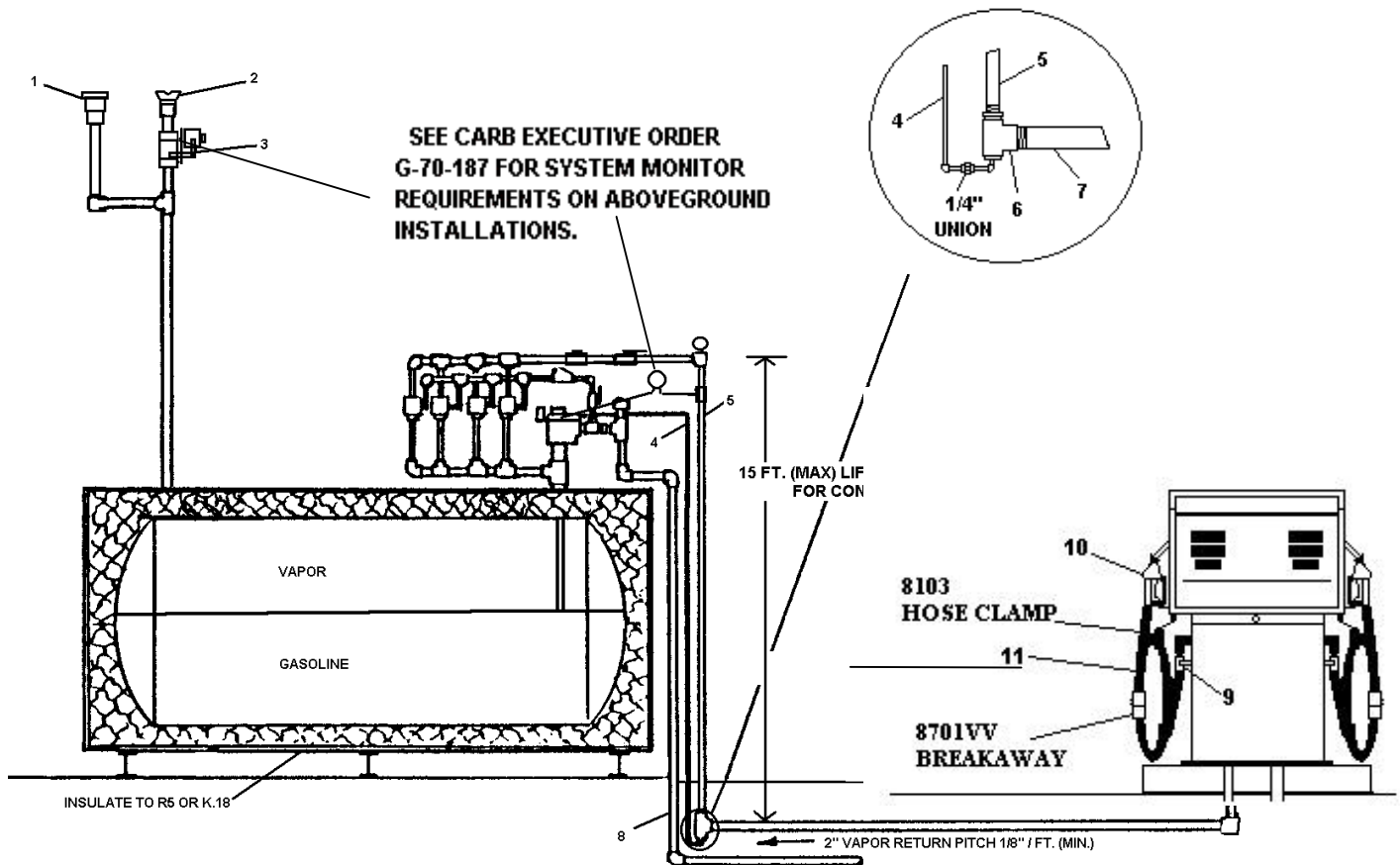

1. +3"wc, - 8"wc P/V Vent Valve, Healy Part #HPVV
2. +1.5"wc Pressure Vent Valve, Healy Part # HPV1.5
3. Vent Sensor Assembly, Healy Part # 6275
4. 1/4" Condensate Line
5. 1" Vapor Return Line

6. 2" TEE
7. 2" Vapor Return Line
8. 2" Product Line
9. Vapor Adapter, Healy Part # CX6-VV1A
10. Nozzle, Healy # 400 ORVR
11. Coaxial Hose Assembly, Healy Series #75B
with Hose Clamp & Breakaway

Executive Order G-70-187 Exhibit 2 Figure 5A

Healy Monitoring System Layout

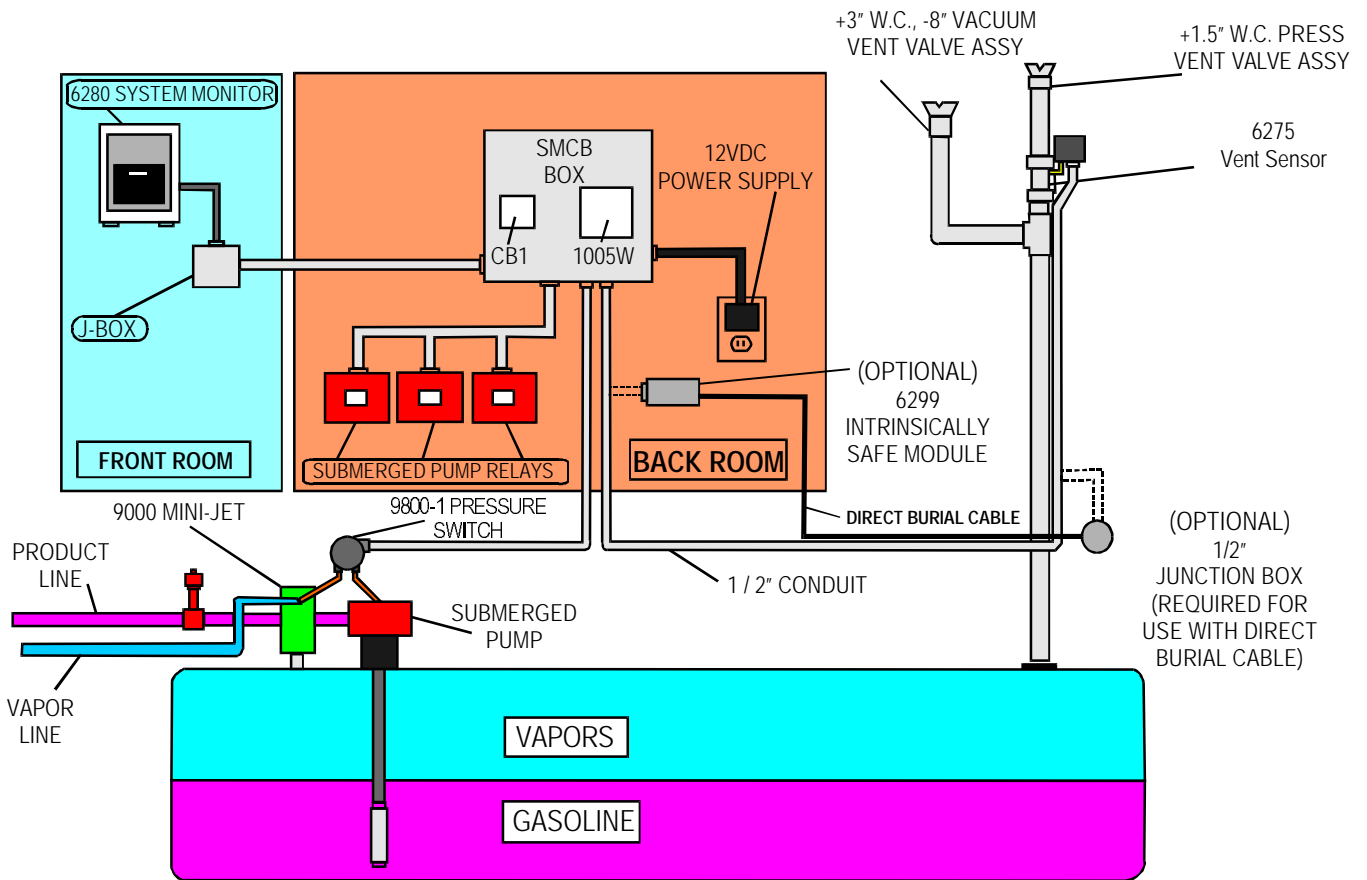

Executive Order G-70-187
Exhibit 2
Figure 5B

SMCB

(SYSTEM MONITOR CONTROL BOX)

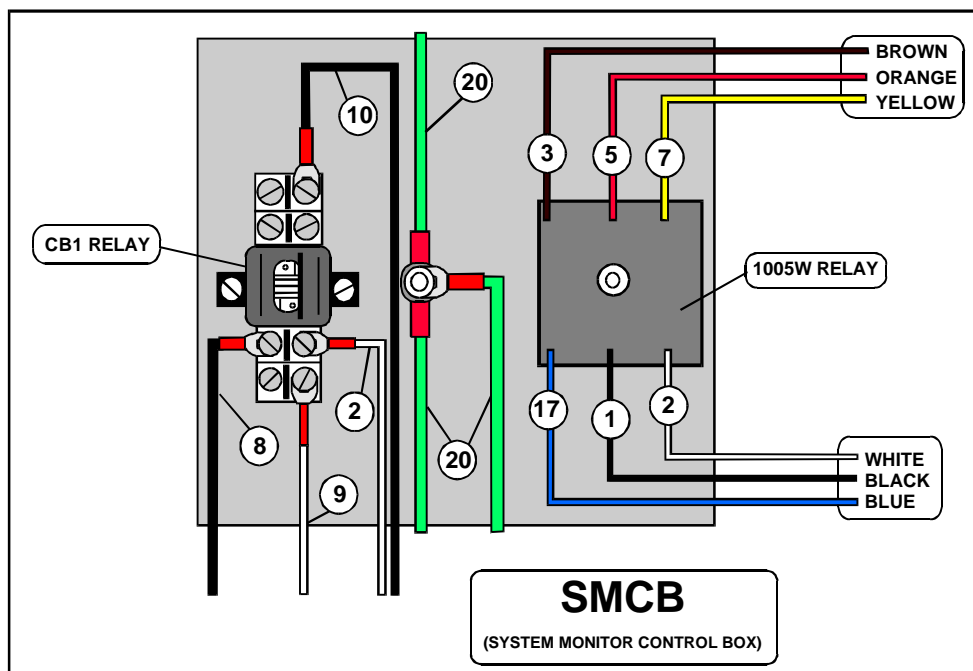

System Monitor Control Box. The SMCB is a junction box for the CB1 relay and the 1005W solid state relay. It also acts as a junction box for the wiring cable supplied from the 6280 System Monitor, the 12VDC plug-in power supply, field wiring from the 9800-1 Differential Pressure Switch, field wiring from the 6275 Vent Sensor Assembly, and field wiring from the Submerged Motor Relays.

The **CB1** Relay, mounted in a socket, is connected to the power of the vacuum source and closes a contact that activates the **yellow Motor L.E.D.** Light on the 6280 System Monitor. It also tells the 6280 System Monitor that the proper vacuum has been achieved, within a prescribed time period, with a signal from the 9800-1 Differential Pressure Switch.

The **1005W** Solid State Relay senses the activation of product pump and transfers that signal to whichever vacuum source is being utilized at the site.

The System Monitor Control Box should be mounted near the Submerged Pump Control Relays and near a 110V standard electrical outlet for the 12VDC plug-in power supply. It should also be accessible to the electrical conduits from the 9800-1 Differential Pressure Switch and the 6275 Vent Sensor Assembly.

**Executive Order G-70-187
Exhibit 2
Figure 5C**

6299

(INTRINSICALLY SAFE MODULE)

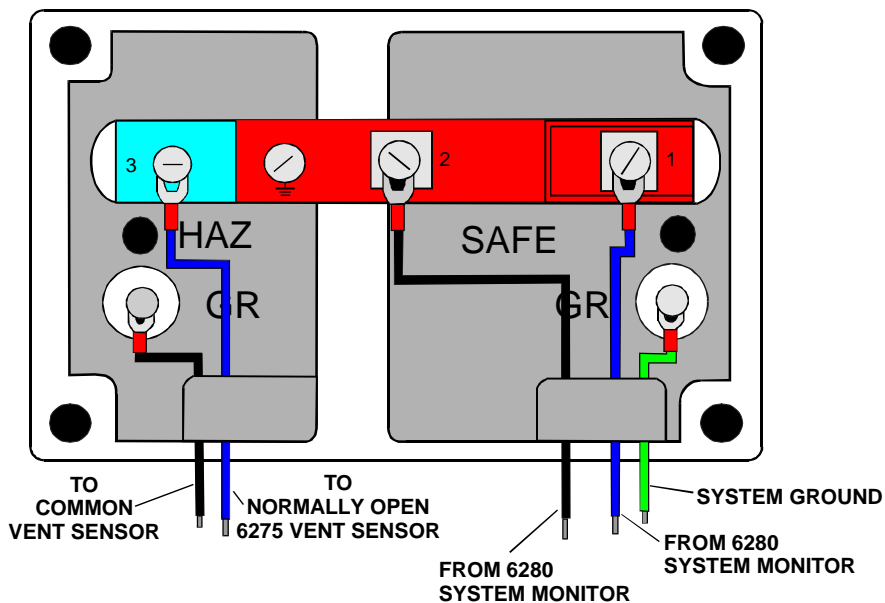

6299 Intrinsically Safe Module. (OPTIONAL) If used, is wired as follows: Mount the unit horizontally, near the pump relays and the **System Monitor Control Box (SMCB)**, with the "HAZARD" and "SAFE" openings down. The conduit wiring (16 AWG, NEC Class 1, 600VAC) passes through two hazardous classified areas and must be sealed per the NEC on each end. Follow usual burial instructions per the NEC for getting the wires to the **6275 Vent Sensor**. Intrinsically safe wires require a dedicated, sealed conduit and cannot be run in the same conduit with any other type wire or voltage. The two signal wires from the control box (**SMCB**) which feed the IS module enter through the "SAFE" conduit opening and must be dressed to stay on that side of the built-in barrier. The GROUND wire also passes through this conduit. This ground wire has to be hard wired back to the service entrance ground. The conduit of these three wires does *not* need to be sealed. The two wires which go to the vent monitor leave the IS module through the "HAZARD" side conduit and must also be dressed to stay on their side of the barrier. This conduit *does have to be sealed* in the usual manner for a "HAZARDOUS LOCATION".

**Executive Order G-70-187
Exhibit 2
Figure 5D**

**9800-1
(VACUUM MONITOR PRESSURE SWITCH)**

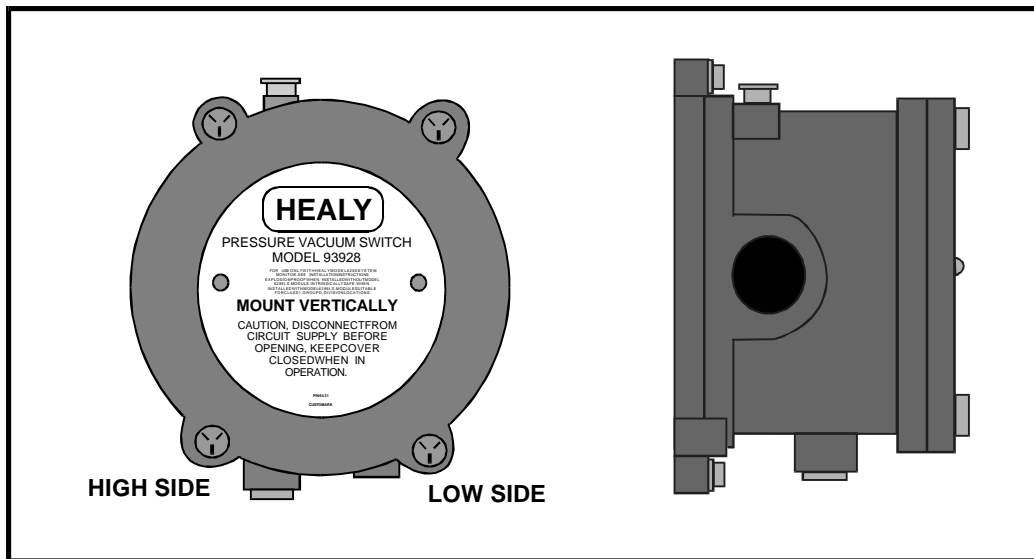

9800-1 Vacuum Monitor Pressure Switch. The 9800-1 Vacuum Switch is mounted on the Phase II Vapor Return line from the gasoline dispensers near or on the vacuum source. Two wires (16 or 18 AWG) from the **SMCB** exit the building through a sealed conduit (per NEC). These wires must be 600 volt rated, Class 1 type insulation. They connect to the switch terminals common (COM.) and normally open (NO) inside the 9800-1 Vacuum Switch. See Healy Systems wiring diagram 9200-6308 (REV 4) sheets 1 and 2 for general layout and installation requirements.

Executive Order G-70-187

Exhibit 2

Figure 5E

Vent Piping Detail

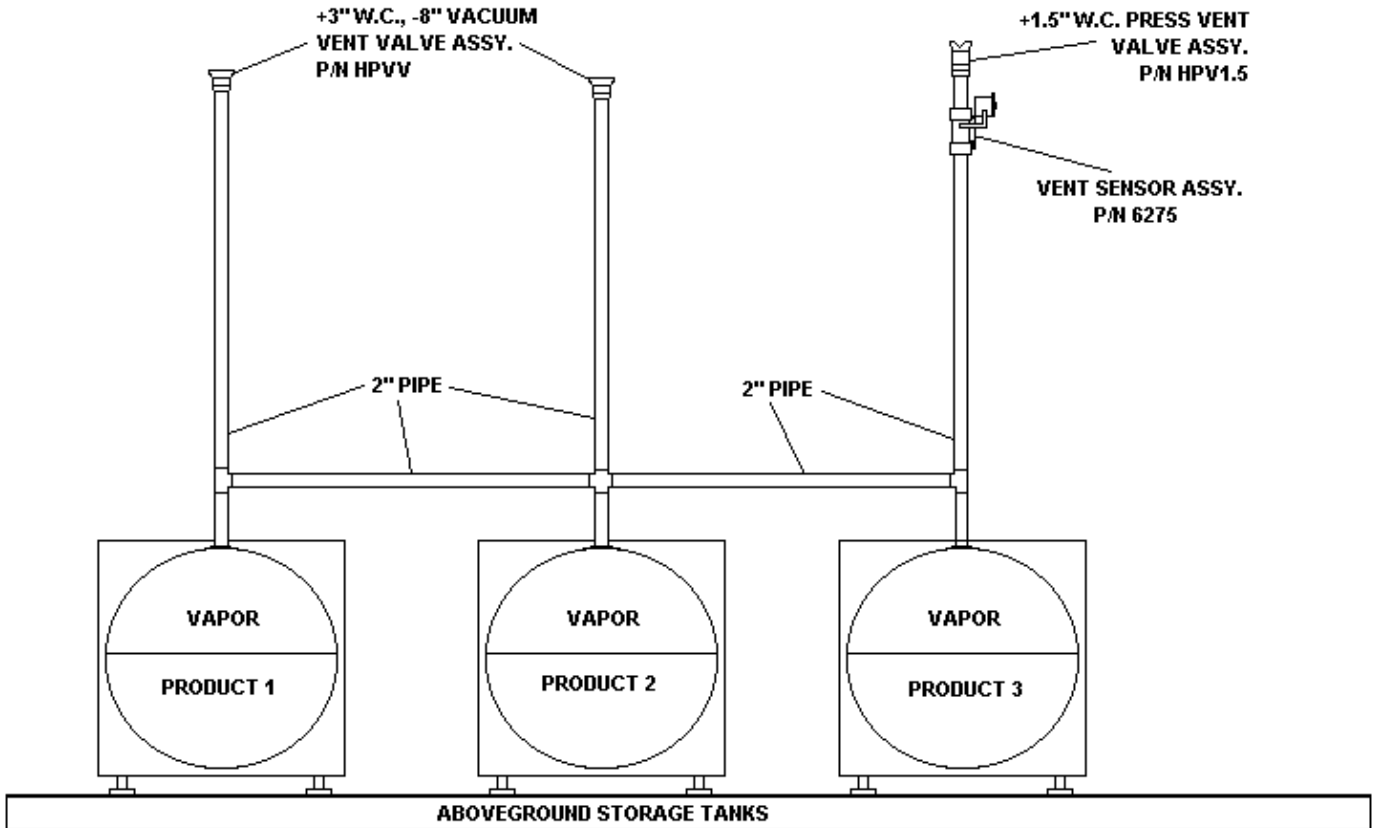

Executive Order G-70-187 Exhibit 2 Figure 5F

Vent Manifold Assembly

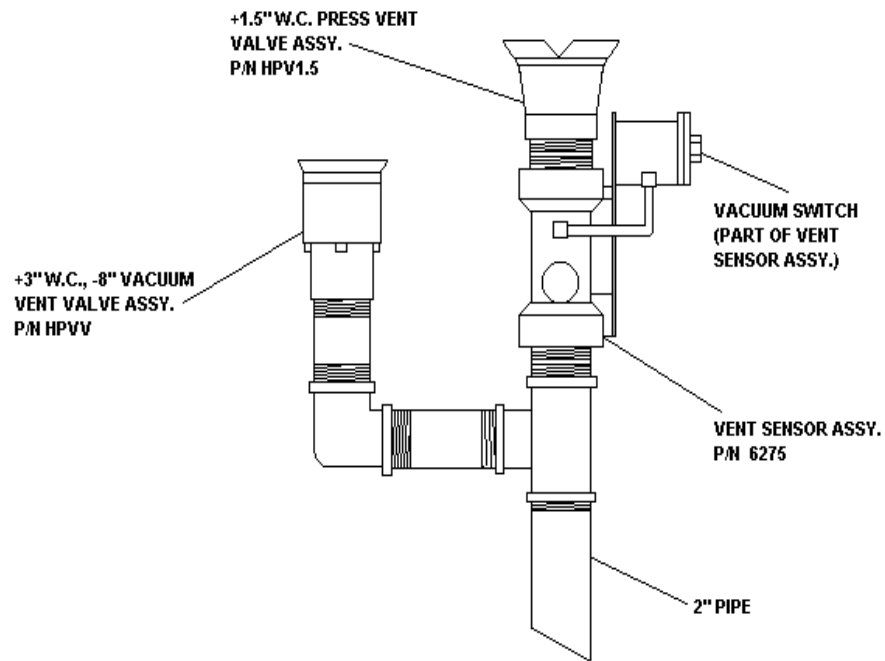

Executive Order G-70-187
Exhibit 2
Figure 5G

6275
(SYSTEM MONITOR VENT SENSOR)

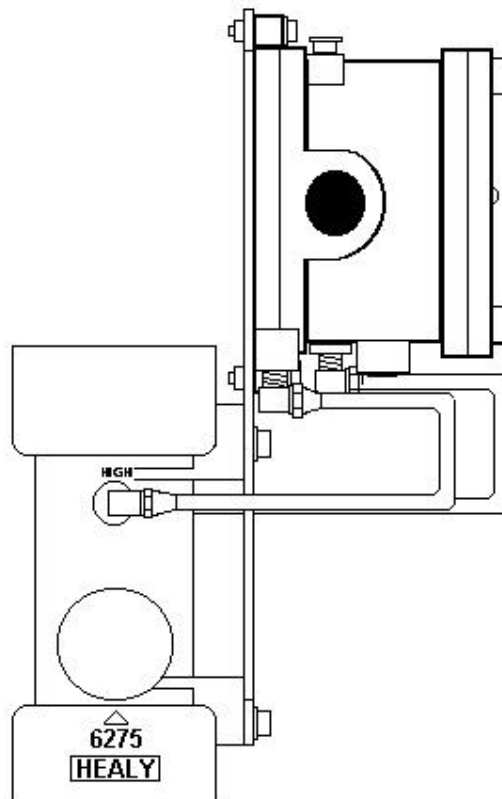

6275 System Monitor Vent Sensor. The 6275 Vent Sensor is mounted on top of the manifolded vent pipes below the +1.5" W.C. Pressure Vent Valve (P/N #HPV1.5) (see Exhibit 2 Figures 5E and 5F). Two wires (16 or 18 AWG) from the SMCB exit the building through a sealed conduit (per NEC). These wires must be 600 volt rated, Class 1 type insulation. They connect to the switch terminals common (COM.) and normally open (NO) inside the 6275 Vent Sensor Switch which is an integral part of the Vent Sensor Assembly. See Healy Systems wiring diagram 9200-6308 (REV 4) sheets 1 and 2 for general layout and installation requirements.

Executive Order G-70-187 Exhibit 2 Figure 6

MONITOR MAINTENANCE LOG SHEET

FACILITY			SUPERVISOR / CONTACT NAME		
ADDRESS			() FACILITY PHONE NUMBER		
CITY	STATE	ZIP CODE	INSTALLATION DATE		

Date & Time of Alarm	Type of Alarm	Date & Time Maintenance Called	Date Maintenance Performed	Maintenance Contractor: Phone: ()
				Maintenance Performed
Date:	<input type="checkbox"/> Vacuum:	Date:	Date:	A. Test(s) Conducted:
Time:	<input type="checkbox"/> Vent:	Time:		
Comments:				B. Test Results: (Attach Additional Sheets If Needed)
				C. Component(s) Repaired or Replaced:

Executive Order G-70-187

Exhibit 3

STATIC PRESSURE INTEGRITY TEST ABOVEGROUND STORAGE TANKS

1 Applicability

This test procedure is used to quantify the vapor tightness of vapor recovery systems installed at gasoline dispensing facilities (GDF) equipped with vacuum assist systems which require pressure/vacuum (P/V) valves. Systems equipped with a P/V valve(s) allowed to have a designed cracking pressure less than 2.5 inches H₂O shall be bagged to eliminate any flow contribution through the valve assembly from the test results. The valve/vent pipe connection, however, shall remain unobstructed during this test.

2 Principle

- 2.1** The entire vapor recovery system is pressurized with nitrogen to two (2.0) inches H₂O. The system pressure is then allowed to decay and the pressure after five (5) minutes is compared with an allowable value. The minimum allowable five-minute final pressure is based on the system ullage and pressure decay equations. For the purpose of compliance determination, this test shall be conducted after installation of all Phase I and Phase II components, including P/V valves, and all back-filling and paving has been completed.
- 2.2** For GDF equipped with a coaxial Phase I system, this test shall be conducted at a Phase II vapor riser. For GDF which utilize a two-point Phase I system, this test may be conducted at either (1) a Phase II vapor riser, (2) a Phase I vapor coupler or (3) an unused storage tank port provided that the vapor coupler poppet valve is leak free as determined by the method set forth in Section 6.7. If the vapor poppet valve is leak free, it is recommended that this test be conducted at the Phase I vapor coupler or an unused storage tank port.

3 Range

- 3.1** If mechanical pressure gauges are employed, the full-scale range of the pressure gauges shall be 0-2.0, 0-1.0, and 0-0.50 inches H₂O column. Maximum incremental graduations of the pressure gauge shall be 0.05 inches H₂O and the minimum accuracy of the gauge shall be three percent of full scale. The minimum diameter of the pressure gauge face shall be 4 inches. A 0-2 inches H₂O inclined manometer, or equivalent, may be used provided that the minor scale divisions do not exceed 0.02 inches H₂O.
- 3.2** If an electronic pressure measuring device is used, the full-scale range of the device shall not exceed 0-10 inches H₂O with a minimum accuracy of 0.5 percent of full-scale. A 0-20 inches H₂O device may be used, provided the equivalent accuracy is not less than 0.25 percent of full scale.
- 3.3** The minimum and maximum nitrogen feed-rates, into the system, shall be one (1) and five (5) CFM, respectively.

4 Interferences

- 4.1 Introduction of nitrogen into the system at flowrates exceeding five (5) CFM may bias the results of the test toward non-compliance. Only gaseous nitrogen shall be used to conduct this test. Air, liquefied nitrogen, helium, or any gas other than nitrogen **shall not be used** for this test procedure.
- 4.2 The results of this Static Pressure Integrity Test shall not be used to verify compliance if an Air to Liquid Volumetric Ratio Test (Test Procedure TP-201.5 or equivalent) was conducted within the 24 hours prior to this test.

Figure 3-1

"T" Connector Assembly

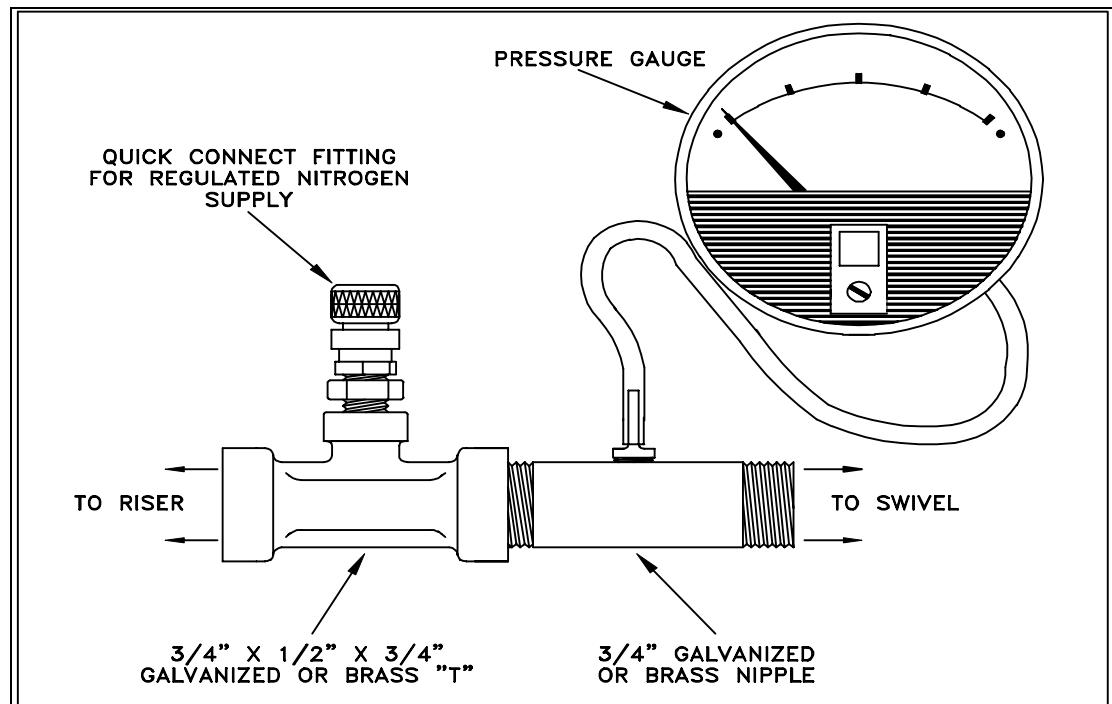

5 Apparatus

- 5.1** Nitrogen. Use commercial grade nitrogen in a high-pressure cylinder, equipped with a two-stage pressure regulator and a one-psig pressure relief valve.
- 5.2** Pressure Measuring Device. Use 0-2.0, 0-1.0, and 0-0.50 inches H₂O pressure gauges connected in parallel, a 0-2 inches H₂O manometer, or an electronic pressure measuring device to monitor the pressure decay in the vapor recovery system. The pressure measuring device shall, at a minimum, be readable to the nearest 0.05 inches H₂O.
- 5.3** "T" Connector Assembly. See Figure 3-1 for example.
- 5.4** Vapor Coupler Integrity Assembly. Assemble OPW 633-A, 633-B, and 634-A adapters, or equivalent, as shown in Figure 3-2. If the test is to be conducted at the storage tank Phase I vapor coupler, this assembly shall be used prior to conducting the static leak test in order to verify the pressure integrity of the vapor poppet. The internal volume of this assembly shall not exceed 0.1 cubic feet.

Figure 3-2

Vapor Coupler Integrity Assembly

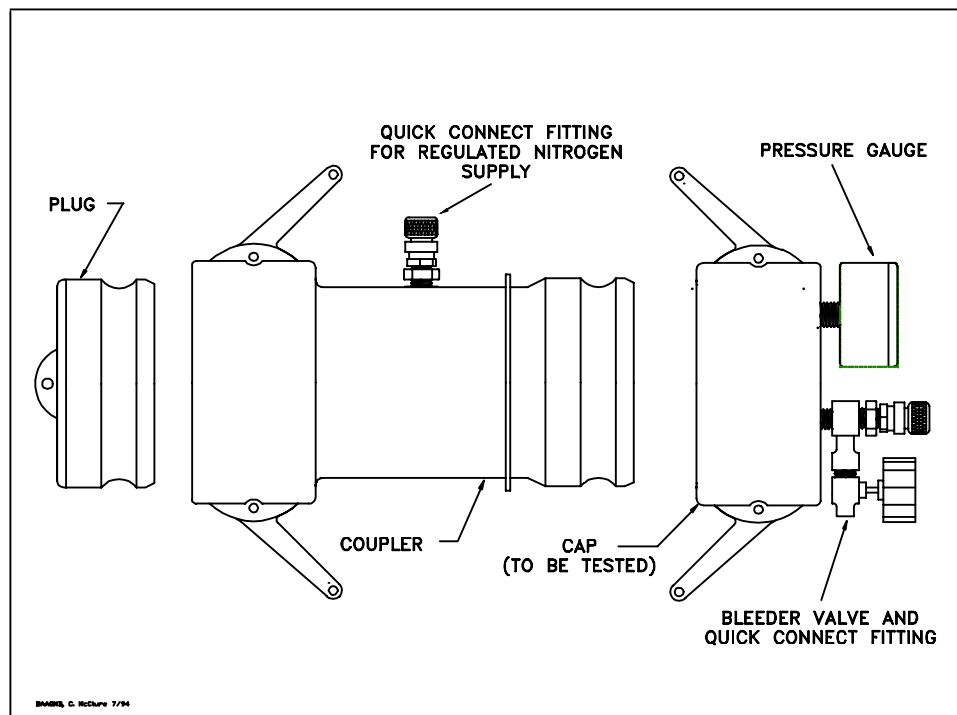

- 5.5** Vapor Coupler Test Assembly. Use a compatible OPW 634-B cap, or equivalent, equipped with a center probe to open the poppet, a pressure measuring device to monitor the pressure decay, and a connection for the introduction of nitrogen into the system. See Figure 3-3 for an example.

Figure 3-3

Vapor Coupler Test Assembly

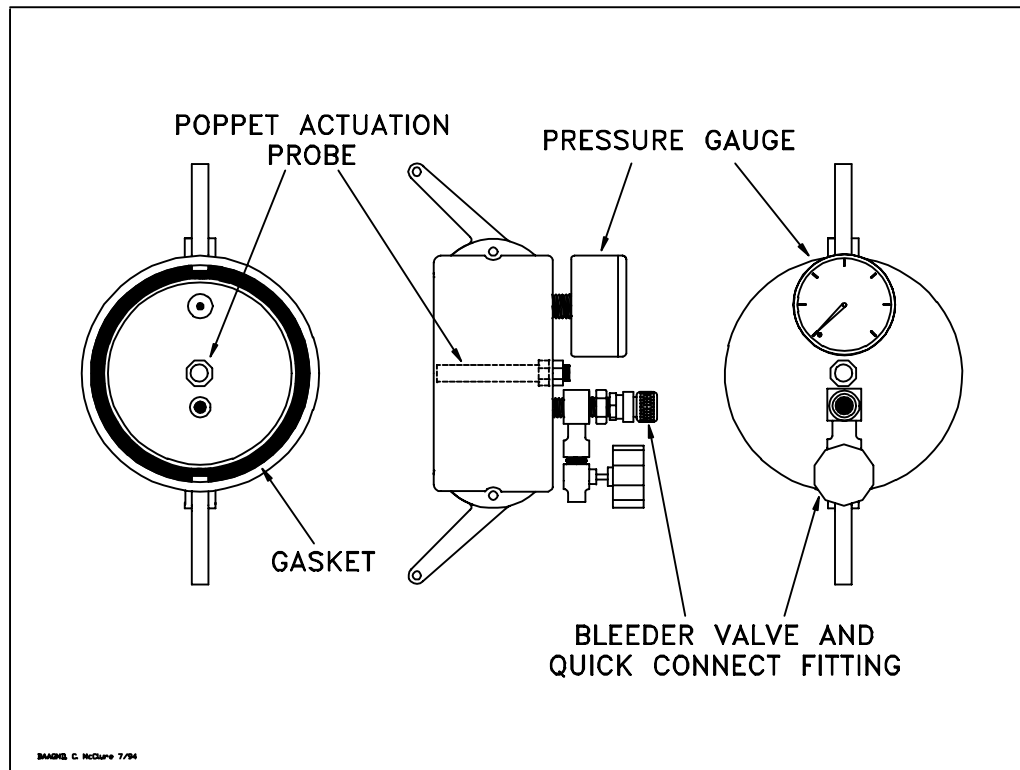

- 5.6 Stopwatch. Use a stopwatch accurate to within 0.2 seconds.
- 5.7 Flowmeter. Use a Dwyer flowmeter, Model RMC-104, or equivalent, to determine the required pressure setting of the delivery pressure gauge on the nitrogen supply pressure regulator. This pressure shall be set such that the nitrogen flowrate is between 1.0 and 5.0 CFM.
- 5.8 Combustible Gas Detector. A Bacharach Instrument Company, Model 0023-7356, or equivalent, may be used to verify the pressure integrity of system components during this test.
- 5.9 Leak Detection Solution. Any liquid solution designed to detect vapor leaks may be used to verify the pressure integrity of system components during this test.

6 Pre-test Procedures

- 6.1 The following safety precautions shall be followed:
- Only nitrogen shall be used to pressurize the system.
 - A one psig relief valve shall be installed to prevent the possible over-pressurizing of the storage tank.
 - A ground strap should be employed during the introduction of nitrogen into the system.

- 6.2** Failure to adhere to any or all of the following time and activity restrictions shall invalidate the test results:
- a.** There shall be no Phase I bulk product deliveries into or out of the storage tank(s) within the three (3) hours prior to the test or during performance of this test procedure.
 - b.** There shall be no product dispensing within thirty (30) minutes prior to the test or during performance of this test procedure.
 - c.** Upon commencement of the thirty minute “no dispensing” portion of this procedure, the headspace pressure in the tank shall be measured. If the pressure exceeds 0.50 inches H₂O, the pressure shall be carefully relieved in accordance with all applicable safety requirements. After the thirty minute “no dispensing” portion of this procedure, and prior to introduction of nitrogen, the headspace pressure shall again be lowered, if necessary, to less than 0.50 inches H₂O.
 - d.** There shall be no Air to Liquid Volumetric Ratio Test (Test Procedure TP-201.5) conducted within the twenty-four (24) hour period immediately prior to this test.
- 6.3** Measure the gallons of gasoline present in each aboveground storage tank and determine the actual capacity of each storage tank from facility records. Calculate the ullage space for each tank by subtracting the gasoline gallonage present from the actual tank capacity. The minimum ullage during the test shall be 25 percent of the tank capacity or 500 gallons for tank sizes greater than 1,000 gallons and 300 gallons for tank sizes equal to or less than 1,000 gallons, whichever is greater. The total ullage shall not exceed 25,000 gallons. These values are exclusive of all vapor piping volumes.
- 6.4** For top mounted two-point Phase I systems, this test shall be conducted with the dust cap removed from the vapor coupler if the test is conducted by pressurizing the system at the Phase II vapor riser or an unused storage tank port. For remote vapor return systems, this test shall be conducted at the Phase II vapor riser or an unused storage tank port with all valves and caps on the vapor return line in place.
- 6.5** For coaxial Phase I systems, this test shall be conducted by pressurizing the system at the Phase II vapor riser or an unused storage tank port with the dust cap removed from the Phase I coupler. This is necessary to insure the vapor tightness of the Phase I vapor poppet.
- 6.6** If the Phase I spill containment box (when installed) is equipped with a drain valve, the valve assembly may be cleaned and lubricated prior to the test. This test shall, however, be conducted with the drain valve installed and the manhole cover removed
- 6.7** If the test is to be conducted at a Phase II vapor riser, disconnect the dispenser end of one vapor recovery hose and install the "T" connector assembly (see Figure 3-1). Connect the nitrogen gas supply (do not use air) and the pressure measuring device to the "T" connector. For those Phase II systems utilizing a dispenser mounted remote vapor check valve, the “T” connector assembly shall be installed on the vapor riser side of the check valve.
- 6.8** If this test is to be conducted at the Phase I vapor coupler on a two-point Phase I system, the procedures set forth in subsections 6.7.1 and 6.7.2 shall be successfully completed prior to testing. The static pressure integrity test shall not be conducted at the Phase I coupler at facilities equipped with coaxial Phase I systems.
- a.** Connect the Vapor Coupler Integrity Assembly to the Phase I vapor coupler. Connect the Vapor Coupler Test Assembly. Connect the nitrogen supply to the assembly and carefully pressurize the internal volume of the assembly to two (2.0) inches H₂O. Start the stopwatch. Record the final pressure after one minute.

- b. If the pressure after one minute is less than 0.25 inches H₂O, the leak rate through the Phase I vapor poppet precludes conducting the static leak test at this location. If the pressure after one minute is greater than or equal to 0.25 inches H₂O, the static leak test may be conducted at this location. This criteria assures a maximum leak rate through the Phase I vapor poppet of less than 0.0004 cubic feet per minute.
 - c. Disconnect the Vapor Coupler Integrity Assembly from the Phase I vapor coupler. If the requirements of subsection 6.7.2 were met, connect the Vapor Coupler Test Assembly to the Phase I vapor coupler.
 - d. As an alternate to the requirements of subsections 6.7.1 through 6.7.3, leak detection solution may be used to verify the absence of vapor leaks through the Phase I vapor poppet on two-point Phase I systems. This alternative leak check is valid only for two-point Phase I systems in which tanks are manifolded. The manifold may be at the vent pipes. Pressurize the system to two (2) inches H₂O and use the leak detection solution to verify a zero leak (absence of bubbles) condition at one of the vapor poppets on the Phase I system.
- 6.9** All pressure measuring device(s) shall be bench calibrated using either a reference gauge or incline manometer. Calibration shall be performed at 20, 50, and 80 percent of full scale. Accuracy shall be within two percent at each of these calibration points. Calibrations shall be conducted on a frequency not to exceed 90 days.
- 6.10** Use the flowmeter to determine the nitrogen regulator delivery pressures which correspond to nitrogen flowrates of 1.0 and 5.0 CFM. These pressures define the allowable range of delivery pressures acceptable for this test procedure. Also record which regulator delivery pressure setting, and the corresponding nitrogen flowrate that will be used during the test. As an alternative, the flowmeter may be connected, in-line between the nitrogen supply regulator and Vapor Coupler Test Assembly, during the test.
- 6.11** Use Equation 9.2 to calculate the approximate time required to pressurize the system ullage to the initial starting pressure of two (2.0) inches H₂O. This will allow the tester to minimize the quantity of nitrogen introduced into those systems which cannot comply with the static leak standards.
- 6.12** Attach the Vapor Coupler Test assembly to the Phase I poppet or the "T" connector assembly to the Phase II vapor riser. Read the initial pressure of the storage tank and aboveground piping. If the initial pressure is greater than 0.5 inches H₂O, carefully bleed off the pressure, in accordance with all applicable safety procedures, in the storage tank and aboveground piping to less than 0.5 inches H₂O column.

7 Testing

- 7.1** Open the nitrogen gas supply valve and set the regulator delivery pressure within the allowable range determined in Section 6.9, and start the stopwatch. Pressurize the vapor system (or subsystem for individual vapor return line systems) to **at least 2.2 inches H₂O** initial pressure. It is critical to maintain the nitrogen flow until the pressure stabilizes, indicating temperature and vapor pressure stabilization in the tanks. Check the test equipment using leak detecting solution or a combustible gas detector to verify that all test equipment is leak tight.
- a. If the time required to achieve the initial pressure of two (2.00) inches H₂O exceeds twice the time derived from Equation 9.2, stop the test and use a liquid leak detector, or a combustible gas detector, to find the leak(s) in the system. Failure to achieve the initial starting pressure within twice the time derived from Equation 9.2 demonstrates the inability of the system to meet the performance criteria. Repair or replace the faulty component(s) and restart the test pursuant to Section 7.1.

- 7.2** Close and disconnect the nitrogen supply. Start the stopwatch when the pressure has decreased to the initial starting pressure of two (2.0) inches H₂O.
- 7.3** At one-minute intervals during the test, record the system pressure. After five minutes, record the final system pressure. See Table 3-I (or Equation 9.1) to determine the acceptability of the final system static pressure results. For intermediate values of ullage in Tables 3-I, linear interpolation may be employed.
- 7.4** If the system failed to meet the criteria set forth in Table 3-I (or Equation 9-2), re-pressurize the system and check all accessible vapor connections using leak detector solution or a combustible gas detector. If vapor leaks in the system are encountered, repair or replace the defective component and repeat the test. Potential sources of leaks include nozzle check valves, pressure/vacuum relief valves, containment box drain valve assemblies, and plumbing connections at the risers.
- 7.5** After the remaining system pressure has been relieved, remove the "T" connector assembly and reconnect the vapor recovery hose, if applicable.
- 7.6** If the vapor recovery system utilizes individual vapor return lines, repeat the leak test for each gasoline grade. Avoid leaving any vapor return line open longer than is necessary to install or remove the "T" connector assembly.
- 7.7** If the containment box has a cover-actuated drain valve, repeat the test with the cover in place. In these cases clearly specify, on Form 3-1, which results represent the pressure integrity with and without the cover in place.

8 Post-Test Procedures

Use Table 3-I, or Equation 9.1 to determine the compliance status of the facility by comparing the final five-minute pressure with the minimum allowable final pressure.

9 Calculations

- 9.1** The minimum allowable five-minute final pressure, with an initial pressure of two (2.0) inches H₂O, shall be calculated as follows:

[Equation 9-1]

$$P_f = 2e^{\frac{-500.887}{V}} \quad \text{if } N = 1-6$$

$$P_f = 2e^{\frac{-531.614}{V}} \quad \text{if } N = 7-12$$

$$P_f = 2e^{\frac{-562.455}{V}} \quad \text{if } N = 13-18$$

$$P_f = 2e^{\frac{-593.412}{V}} \quad \text{if } N = 19-24$$

$$P_f = 2e^{\frac{-624.483}{V}} \quad \text{if } N > 24$$

Where:

- N = The number of affected nozzles. For manifolded systems, N equals the total number of nozzles. For dedicated plumbing configurations, N equals the number of nozzles serviced by the tank being tested.
- P_f = The minimum allowable five-minute final pressure, inches H₂O
- V = The total ullage affected by the test, gallons
- E = A dimensionless constant approximately equal to 2.718
- 2 = The initial starting pressure, inches H₂O

- 9.2** The minimum time required to pressurize the system ullage from zero (0) to two (2.0) inches H₂O gauge pressure shall be calculated as follows:

$$t_2 = \frac{V}{[1522] F} \quad \text{[Equation 9-2]}$$

Where:

- t_2 = The minimum time to pressurize the ullage to two inches H₂O, minutes
- V = The total ullage affected by the test, gallons
- F = The nitrogen flowrate into the system, CFM
- 1522 = The conversion factor for pressure and gallons

- 9.3** If the policy of the local District requires an allowable tolerance for testing error, the minimum allowable five-minute final pressure, including testing error, shall be calculated as follows:

$$P_{f-E} = 2 - \left[1 + \left(\frac{E}{100} \right) \right] [408.9 - (P_f + 406.9)] \quad \text{[Equation 9-3]}$$

Where:

- P_{f-E} = The minimum allowable five-minute final pressure including allowable testing error, inches H₂O
- E = The allowable testing error, percent
- P_f = The minimum allowable five-minute final pressure calculated in Equations 9-1 or 9-2, inches H₂O
- 2 = The initial starting pressure, inches H₂O
- 408.9 = Atmospheric pressure plus the initial starting pressure, inches H₂O
- 406.9 = Atmospheric pressure, inches H₂O

10 **Reporting**

The calculated ullage and system pressures for each five-minute vapor recovery system test shall be reported as shown in Form 3-1. Be sure to include the Phase I system type (two-point or coaxial), the Phase II system type, whether the system is manifolded, and the one-minute pressures during the test.

Executive Order G-70-187

TABLE 3-1

Pressure Decay Leak Rate Criteria
Initial Pressure of 2 inches of H₂O
Minimum Pressure After 5 Minutes, inches of H₂O

Ullage (Gallons)	Number of Affected Nozzles				
	01-06	07-12	13-18	19-24	>24
500	0.73	0.69	0.65	0.61	0.57
550	0.80	0.76	0.72	0.68	0.64
600	0.87	0.82	0.78	0.74	0.71
650	0.93	0.88	0.84	0.80	0.77
700	0.98	0.94	0.90	0.86	0.82
750	1.03	0.98	0.94	0.91	0.87
800	1.07	1.03	0.99	0.95	0.92
850	1.11	1.07	1.03	1.00	0.96
900	1.15	1.11	1.07	1.03	1.00
950	1.18	1.14	1.11	1.07	1.04
1,000	1.21	1.18	1.14	1.10	1.07
1,200	1.32	1.28	1.25	1.22	1.19
1,400	1.40	1.37	1.34	1.31	1.28
1,600	1.46	1.43	1.41	1.38	1.35
1,800	1.51	1.49	1.46	1.44	1.41
2,000	1.56	1.53	1.51	1.49	1.46
2,200	1.59	1.57	1.55	1.53	1.51
2,400	1.62	1.60	1.58	1.56	1.54
2,600	1.65	1.63	1.61	1.59	1.57
2,800	1.67	1.65	1.64	1.62	1.60
3,000	1.69	1.68	1.66	1.64	1.62
3,500	1.73	1.72	1.70	1.69	1.67
4,000	1.76	1.75	1.74	1.72	1.71
4,500	1.79	1.78	1.77	1.75	1.74
5,000	1.81	1.80	1.79	1.78	1.77
6,000	1.84	1.83	1.82	1.81	1.80
7,000	1.86	1.85	1.85	1.84	1.83
8,000	1.88	1.87	1.86	1.86	1.85
9,000	1.89	1.89	1.88	1.87	1.87
10,000	1.90	1.90	1.89	1.88	1.88
15,000	1.93	1.93	1.93	1.92	1.92
20,000	1.95	1.95	1.94	1.94	1.94
25,000	1.96	1.96	1.96	1.95	1.95

Note: For manifolded Phase II Systems, the "Number of Affected Nozzles" shall be the total of all gasoline nozzles. For dedicated return configurations, the "Number of Affected Nozzles" shall be the total of those nozzles served by the tank being tested.

**Executive Order G-70-187
Exhibit 3
Form 3-1**

Summary of Source Test Results			
Source Information		Facility Parameters	
GDF Name and Address _____ _____ _____	GDF Representative and Title _____ _____ GDF Phone No. () _____	PHASE I SYSTEM TYPE (Check One) Two Point <input style="float: right;" type="checkbox"/> Coaxial <input style="float: right;" type="checkbox"/> Coaxial with Spill Prevention <input style="float: right;" type="checkbox"/>	
Permit Conditions _____	Source: GDF Vapor Recovery System GDF # _____ A/C # _____	PHASE II SYSTEM TYPE <input style="float: right;" type="checkbox"/> Healy 400 ORVR Manifolded? Y or N	
Operating Parameters: Number of Nozzles Served by Tank #1 _____ Number of Nozzles Served by Tank #3 _____ Number of Nozzles Served by Tank #2 _____ Total Number of Gas Nozzles at Facility _____			
Applicable Regulations:		FOR OFFICE USE ONLY:	

Source Test Results and Comments:

TANK #:	1	2	3	TOTAL
1. Product Grade	_____	_____	_____	_____
2. Actual Tank Capacity, Gallons	_____	_____	_____	_____
3. Gasoline Volume, Gallons	_____	_____	_____	_____
4. Ullage, Gallons (#2 -#3)	_____	_____	_____	_____
5. Phase I System Type	_____	_____	_____	_____
6. Initial Test Pressure, Inches H ₂ O (2.0)	_____	_____	_____	_____
7. Pressure After 1 Minute, Inches H ₂ O	_____	_____	_____	_____
8. Pressure After 2 Minutes, Inches H ₂ O	_____	_____	_____	_____
9. Pressure After 3 Minutes, Inches H ₂ O	_____	_____	_____	_____
10. Pressure After 4 Minutes, Inches H ₂ O	_____	_____	_____	_____
11. Final Pressure After 5 Minutes, Inches H₂O	_____	_____	_____	_____
12. Allowable Final Pressure from Table 3-1	_____	_____	_____	_____
13. Test Status [Pass or Fail]	_____	_____	_____	_____

Test Conducted by: _____	Test Company Name _____ Address _____ City _____	Date and Time of Test: Run A: _____ Run B: _____ Run C: _____
--------------------------	---	--

Executive Order G-70-187

Exhibit 4

Vapor Return Line Vacuum Integrity Test for the Healy Model 400 ORVR System

1 Applicability

This test procedure is used to verify the vapor tightness of the portion of the Healy system which is subjected to relatively high levels of vacuum in the vapor return lines. A defective vapor valve, or any other defect which compromises the integrity of the vapor lines from the nozzle to the central vacuum unit, may cause the ingestion of large amounts of air. Excess air in the storage tanks will cause significant vent emissions when the pressure exceeds the pressure setting of the P/V valve. Ingested air will also cause the evaporation of gasoline in the storage tanks and may result in observable product shrinkage.

Note: This test is required in addition to, and not as an alternative for, the static pressure decay test in [Exhibit 3](#).

2 Principle

The vapor lines from the nozzle to the central vacuum unit are isolated from the aboveground storage tanks by closing the vapor and siphon line ball valves after activating the central vacuum unit. The unit is turned off and the vacuum is allowed to decay. The value is compared with an allowable value.

3 Range

- 3.1 If mechanical pressure gauges are employed, the full-scale range of the pressure gauges shall be zero to 100 inches water column (0 - 100" wc), to be sensed as vacuum. Maximum incremental graduations of the pressure gauge shall be 2 inches wc and the minimum accuracy of the gauge shall be three percent of full scale. The minimum diameter of the pressure gauge face shall be four (4) inches.
- 3.2 If an electronic pressure measuring device is used, the full scale range of the device shall not exceed zero to 200 inches water column (0 - 200" wc) with a minimum accuracy of 0.5 percent of full scale.

4 Interferences

Any attempts to dispense product during the test will open the lines being tested and invalidate the results.

5 Apparatus

- 5.1 Pressure Measuring Device. Use a pressure gauge, or an electronic pressure measuring device, set up to measure vacuum, to monitor the decay of the vacuum level in the vapor return lines. The pressure measuring device shall, at a minimum, be readable to 2 inches water column.
- 5.2 Stopwatch. Use a stopwatch accurate to within 0.2 seconds.

6 Pre-Test Procedures

- 6.1 There shall be no product dispensing during the test.
- 6.2 All pressure measuring device(s) shall be bench calibrated using either a reference gauge or incline manometer. Calibration shall be performed at 20, 50 and 80 percent of full scale. Accuracy shall be within two percent at each of these calibration points. Calibrations shall be conducted on a frequency not to exceed 90 days.

- 6.3 Remove the tap or quick-connect cap and install the pressure measuring device. The device shall be installed in the portion of the vapor line to be isolated.

7 Testing

- 7.1 Turn on the central vacuum unit (CVU) by activating a dispenser. The CVU is turned off by replacing the nozzle on the dispenser. Alternatively, the test may be conducted immediately following product dispensing.
- 7.2 Observe the vacuum level on the pressure measuring device. When the vacuum level is stable, or at the end of the dispensing operation, close the vapor and siphon line ball valves to isolate the vapor lines from the storage tanks (refer to Exhibit 2, Figures 2A thru 2D and Figure 3 for the location of the ball valves) and turn off the CVU by replacing the nozzle on the dispenser. If a stable vacuum level is not observed after one minute of CVU operation, or if the stable vacuum level is less than that indicated in Exhibit 2 as within the normal vacuum level for the CVU installed, turn off the CVU and check for problems before proceeding with the test.
- 7.3 Note the initial vacuum level and start the stopwatch. Record the vacuum level at one minute intervals. After five minutes, record the final vacuum level.
- 7.4 Calculate the difference between the final vacuum level and the initial vacuum level to obtain the observed change in vacuum. Note this value as the "measured DP". Estimate the total length of 2 inch diameter vapor return pipe from the dispensers to the CVU. Use this value to obtain the "calculated DP" in equation 4.1. If the "measured DP" is greater than the value obtained by equation 4-1, then a vapor leak is evident and the system has failed. If the vacuum level does not decay more than the allowable level, proceed to Section 8.

Equation 4.1

$$DP = 800/N$$

Where:

N = The approximate length of 2 inch vapor return pipe from the dispensers to the central vacuum unit to the nearest 20 feet .

DP = The observed change in vacuum level in inches of water column during a five minute observation period.

Note: If the station contains 3 inch vapor return pipes, multiply the answer in Equation 4.1 by 0.5. This equation is based on an allowable leak rate of 0.08 gallons per minute.

- 7.5 If the system has failed to meet the criteria set forth in Section 7.4, repair and replace defective components as necessary and repeat the test. Defective nozzles or other components may be diagnosed by bagging with bags containing air and observing collapse of the bags, or by otherwise isolating suspected components.

Note: This is only for diagnostic purposes; the test shall not be conducted with any bagged or isolated components.

- 7.6 If the system contains more than one CVU, repeat for each CVU and associated piping.

8 Post-Test Procedures

- 8.1 Remove the pressure measuring device and plug or cap to ensure that the connection point is leak tight.
- 8.2 Open the valves which were closed to isolate the vapor return lines.

9

Reporting

The observed initial, interim and final vacuum levels observed, the type of pressure measuring device (including range and accuracy and date of last calibration), the number of nozzles associated with the CVU and the measured DP shall be reported.

Executive Order G-70-187

Exhibit 5

Fillneck Vapor Pressure Regulation Fueling Test

1 Applicability

This test procedure is used to verify proper operation of the nozzle boot pressure regulation unique to the Healy Model 400 ORVR nozzle.

2 Principle

The nozzle vapor pressure regulation is verified during refueling into a tight simulated vehicle fuel tank with saturated vapors (Procedure 1) or into an actual non-ORVR equipped vehicle (Procedure 2). Pressure readings are taken with a mechanical gauge during a fueling of at least 5 gallons, excluding the first two gallons and last one gallon dispensed in order to eliminate the interferences due to vapor growth or contraction. A vacuum which exceeds $\frac{1}{2}$ inches wc, or a pressure which exceeds $\frac{1}{4}$ inches wc, except during the excluded beginning and ending gallons, indicates a defective nozzle.

3 Interferences

Vacuum or pressure levels outside of the specified range may occur during the beginning or end of the refueling operation when properly functioning equipment is affected by the following conditions: (1) gasoline dispensed into a vehicle fuel tank which is significantly warmer than the dispensed fuel may cause a vacuum of several inches water column; and, conversely, (2) gasoline dispensed into a vehicle tank which is significantly cooler than the dispensed fuel may temporarily cause a pressure greater than $\frac{1}{4}$ inches water column. The effect of the temperature differential will be most pronounced at the beginning of the fueling operation and tends to gradually disappear toward the end of the fueling operation as fuel and vapor temperatures in the vehicle fuel tank equalize.

4 Apparatus

Mechanical Pressure Gauge - the full scale range of the gauge shall be 1 inch water column pressure to 1 inch water column vacuum (-1.0" wc – +1.0" wc). Maximum incremental graduations of the pressure gauge shall be 0.25 inches wc and the minimum accuracy of the gauge shall be three percent (3%) of full scale. The minimum diameter of the pressure gauge shall be four inches.

4.1 Procedure 1. Use a gauge mounted on the test tank fillneck to measure vapor pressure during fueling of a simulated fuel tank (see Figure 1). Any test tank as approved in Air Resources Board, Source Test Methods, Volume 2, TP-201.5, "Determination (by Volume Meter) of Air to Liquid Volume Ratio of Vapor Recovery Systems of Dispensing Facilities" may be used in lieu of the setup shown in Figure 1.

4.2 Procedure 2. Use a gauge mounted on a stand and placed level on the vehicle during fueling of actual vehicles (see Figure 2).

- 4.3 All pressure measuring device(s) shall be bench calibrated using either a reference gauge or an inclined manometer. Calibration shall be performed at 20, 50 and 80 percent of full scale. Accuracy shall be within two percent (2%) at each calibration point. Instrument Calibrations shall be conducted and a certification report filed periodically every 90 days (or less).

5 Pre-Test Procedures

Verify that the system vacuum source is operating in the 65" to 85" WC operating range. No tears or holes are allowed in or on the nozzle boot or face seal.

Ensure that the high vacuum vapor return lines are tight (see Exhibit 4).

5.1 **Procedure 1 – simulated vehicle fuel tank** (Figure 1).

- a. Position test tank next to dispenser nozzle being tested.
- b. Dispense 1-2 gallons of gasoline into test tank.
- c. Remove nozzle and replace fill cap.
- d. Roll tank back and forth vigorously for thirty seconds to splash saturate the vapor head space in the tank.

5.2 **Procedure 2 – Torus Pressure Test with actual vehicle** (Figure 2).

- a. Place the gauge assembly on the vehicle in a level position.

6 Testing

6.1 **Procedure 1**

- a. Remove the fillpipe cap and insert nozzle, making a seal between the nozzle boot and the test tank fillpipe opening. Dispense gasoline (minimum 5 gallons).
- b. Observe pressure gauge during fueling.
- c. Repeat test for additional nozzles. Drain test tank as necessary.

6.2 **Procedure 2**

- a. Remove the fillpipe cap and position the torus centered over the vehicle fillpipe. Insert nozzle, making a seal between the nozzle boot and the torus and between the torus and fillpipe. Dispense gasoline (minimum 5 gallons).
- b. Observe pressure gauge during fueling.
- c. Repeat test for additional nozzles.

7 Reporting

Record observed operating levels measured for each nozzle tested along with type and model of pressure measuring device used including: range, accuracy and date of last calibration.

Exhibit 5
Figure 1

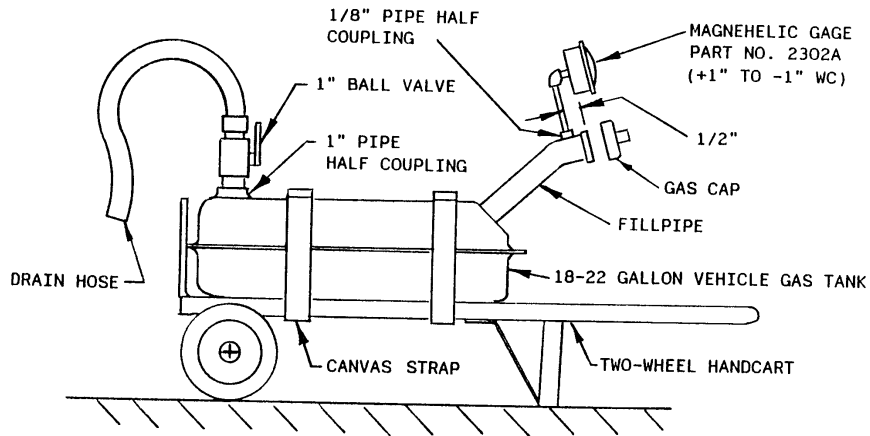
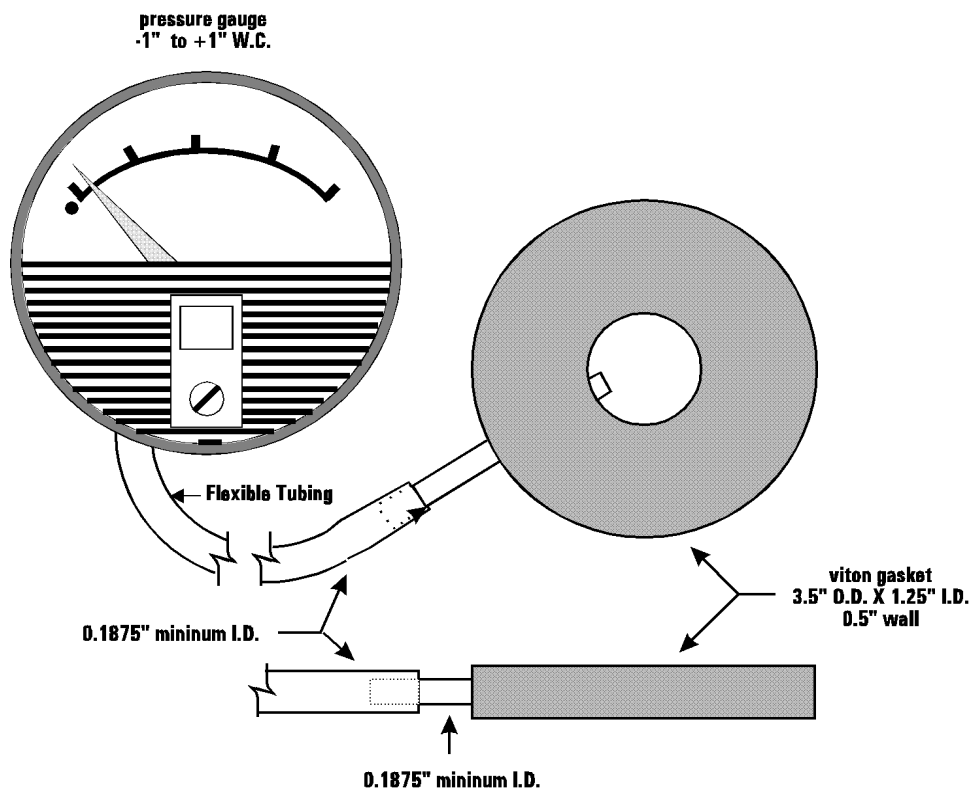

Exhibit 5
Figure 2



EXECUTIVE ORDER G-70-187

EXHIBIT 6

**TEN GALLON PER MINUTE LIMITATION
COMPLIANCE VERIFICATION PROCEDURE**

Compliance with the 10 gallon per minute flowrate limitation shall be determined with the following methodology. It is recommended that the maximum dispensing rate through each nozzle/hose assembly be verified.

1) The facility uses identical models of hoses, nozzles, and breakaways:

Dispense gas into a vehicle or approved container. Dispensing shall be conducted in the “hand-held, wide-open” mode. Using a stopwatch accurate to at least 0.2 seconds, begin timing the dispensing rate after at least one gallon has been dispensed. This one gallon buffer is necessary due to the “slow-start” nature of some dispensers. Determine the time required to dispense 2, 3, 4, or 5 gallons of gasoline. The facility shall be deemed in compliance with the 10 gallon per minute limitations if the elapsed time meets, or exceeds, the times shown in Table 1. If the dispensing rate exceeds the allowable limit, a CARB-certified flow limiting device shall be installed.

2) The facility uses different models of hoses, nozzles, or breakaways

Due to potential differences in pressure drops through the various components, each of the nozzle/hose assemblies shall be tested for maximum dispensing rates. Using the same criteria as above, determine the maximum dispensing rate through each nozzle/hose assembly. If the maximum dispensing rate exceeds the 10 gpm limit, a CARB-certified flow limiting device shall be installed.

**Table 1
Verification of 10 gpm**

Product Dispensed, gallons	Minimum Allowable Time, seconds
2.0	11.8
3.0	17.7
4.0	23.6
5.0	29.5

Note: The times have been corrected to allow for the accuracy of the measurement.