

California Environmental Protection Agency

---



**ARB Approved**

**Installation, Operation, and Maintenance Manual**

**For the OPW Phase I Vapor Recovery System  
As Certified by Executive Order VR-102-Q**

NOTICE:

The **ARB Approved Installation, Operation and Maintenance Manual for the OPW Phase I EVR System** describes the tools and methods required to install the OPW Phase I EVR System. Unless specified otherwise, only technicians that are trained and certified by OPW (i.e. OPW Certified Technicians) are able to perform installation, maintenance or repairs of components manufactured by OPW or the warranty will be void. A list of OPW Certified Technicians can be viewed at <http://www.opw-fc.com> .

To schedule a training class, OPW can be contacted at the following:

OPW Fueling Components  
Phone: 1-800-422-2525  
Web: [www.opw-fc.com](http://www.opw-fc.com)

It is the responsibility of each OPW Certified Technician to be familiar with the current requirements of state, federal and local codes for installation and repair of gasoline dispensing equipment. It is also the responsibility of the OPW Certified Technician to be aware of all necessary safety precautions and site safety requirements to assure a safe and trouble free installation.

Only technicians that are trained and certified by FFS (i.e. FFS Certified Technicians) are able to perform installation, maintenance or repairs of components manufactured by FFS or the warranty will be void. A list of FFS Certified Technicians can be viewed at <http://www.franklinfueling.com/service/>.

To schedule a training class, FFS can be contacted at the following:

Enhanced Vapor Recovery Systems  
Franklin Fueling Systems  
Phone: 800-225-9787  
Email: [techserve@franklinfueling.com](mailto:techserve@franklinfueling.com)

It is the responsibility of each FFS Certified Technician to be familiar with the current requirements of state, federal and local codes for installation and repair of gasoline dispensing equipment. It is also the responsibility of the FFS Certified Technician to be aware of all necessary safety precautions and site safety requirements to assure a safe and trouble free installation.

In addition to the requirements included in this manual, the contractor is responsible for providing the warranty tag, included with each component, to the service station owner/operator at the time of installation.

## Table of Contents

### OPW Installation, Operating and Maintenance Manual

<u>Equipment</u>	<u>Manufacturer/Model Number</u>	<u>Page</u>
Summary of Guidelines for Maintenance Activities		5
Equipment Installation Checklist		8
Typical Installation (Product Side)		11
Typical Installation (Vapor Side)		12
Typical OPW/POMECO Double Fill Configuration		13
Typical Remote Fill Spill Container Configuration		14
Typical Remote Fill Tank Top Configuration		15
Typical Remote Fuel Additive Configuration		16
Spill Containers	OPW 1-2100 Series	17
	OPW 1-2200 Series	21
	OPW 1-3100 Series	26
Replacement Drain Valve Kit	OPW 1DK-2100	31
Replacement Drain Plug	OPW 1DP-2100	34
Dust Caps	OPW 634TT-EVR (product)	38
	OPW 1711T-EVR (vapor)	
	OPW 634LPC (product)	40
	OPW 1711LPC (vapor)	
	CompX CSP1-634LPC (product)	42
	CompX CSP3-1711LPC (vapor)	
	CompX CSP2-634LPC (product)	
	CompX CSP4-1711LPC (vapor)	
Product Adaptor	OPW 61SALP	44
Vapor Adaptor	OPW 61VSA	47

<b>Jack Screw Kit</b>	OPW 61JSK-4410, -44CB	<b>50</b>
	OPW 71JSK-44MA	
	OPW 61JSK-4RMT	<b>56</b>
	OPW 71JSK-4RMT	
	OPW 61JSK-4410 (206206 Rev. C)	<b>60</b>
<b>Face Seal Adaptor</b>	OPW FSA-400	<b>64</b>
	OPW FSA-400-S	
<b>Drop Tube</b>	OPW 61T (various lengths)	<b>67</b>
<b>Drop Tube Overfill Prevention Device<sup>1</sup></b>	OPW 61SO	<b>69</b>
	OPW 71SO/71SO Testable	<b>78</b>
<b>Multi-port</b>	(Installation Instructions)	<b>98</b>
<b>Fibrelite Multiport</b>	(Installation Instructions)	<b>104</b>
<b>Tank Bottom Protector<sup>1</sup></b>	OPW/Pomeco 6111-1400	<b>131</b>
<b>Pressure/Vacuum Vent Valve</b>	OPW 723V	<b>134</b>
	Husky 5885	<b>138</b>
	FFS PV-Zero	<b>141</b>
<b>Tank Gauge Port Adaptor and Cap</b>	Morrison Brothers 305XPA1100AKEVR (cap and adaptor kit)	<b>153</b>
	Morrison Brothers 305-0200AAEVR (replacement adaptor)	
	Morrison Brothers 305XP-110ACEVR (replacement cap)	
	Veeder-Root 312020-952 (cap & adaptor)	<b>154</b>
	OPW 62M Cap and Adaptor	<b>155</b>
<b>Fuel Lock</b>	McGard FS1 – Stick Only Fuel Lock (125007)	<b>158</b>
	McGard FS2 – Stick/Sampling Fuel Lock (125008)	
<b>Bladder Plug</b>	McGard PSI104	<b>160</b>

<sup>1</sup> If these components are installed or required by regulations of other agencies, only those components and model numbers specified above shall be installed or used.

## Summary of Guidelines for Maintenance Activities Required of the OPW Phase I Vapor Recovery System <sup>1</sup>

Component	Interval <sup>2</sup>	Maintenance To Be Performed
<b>Pressure/Vacuum Vent Valve</b>		
Husky 5885	Annual	<ol style="list-style-type: none"> <li>1. Remove screws that hold top cover on.</li> <li>2. Remove any debris that might be sitting inside the lower cover.</li> <li>3. Check the drain holes in the lower cover for blockage.</li> <li>4. Do not remove the two (2) screens.</li> <li>5. Reinstall the top cover and retaining screws.</li> <li>6. Tighten the screws firmly.</li> </ol>
FFS PV-Zero	Annual	<ol style="list-style-type: none"> <li>1. Visually inspect housing, pipe, fittings and rain cap for obvious signs of damage, missing parts or fluid leaks.</li> <li>2. Visually inspect the rain cap, from ground level, for signs of bird nests or insect activity.</li> <li>3. Every <b>year</b>, drain and inspect the fill fluid per the <b>Fluid Inspection Procedure</b>.</li> </ol>
OPW 723V	Annual	<ol style="list-style-type: none"> <li>1. Remove and inspect filter screens.</li> <li>2. Clean or replace as necessary.</li> <li>3. Test as necessary.</li> </ol>
<b>Spill Containers and Drain Valves</b> OPW "All Models"	Annual	Annually, clean the interior of the container and drain valve. Annually, remove accumulated dirt and grit. If the drain valve becomes clogged, remove the valve, soak in water, and use high-pressure air to clean. If valve is removed, reinstall to its proper position and perform ARB Procedure TP-201.1C or TP-201.1D as applicable.
<b>Dust Caps</b> OPW "All Models"	Annual	Visually inspect the seal in cap and replace if damaged or missing.
CompX "All Models"	Annual	Inspect dust cap seal for nicks, tears or deformations and replace if necessary.
<b>Product Adaptor</b> OPW 61SALP	Annual	Visually inspect the adaptor for large dents, cracks, or deformations. Verify the static torque of the swivel adaptor by performing California ARB test procedure TP-201.1B.

<sup>1</sup> These maintenance requirements shall not circumvent use of the manufacturer's installation and maintenance instructions. Maintenance contractors or owner/operators shall refer to the manufacturers complete installation and maintenance instructions found herein for the OPW Phase I System to ensure that all maintenance and torque requirements are met.

<sup>2</sup> Maintenance must be conducted within the interval specified from the date of installation and at least within the specified interval thereafter.

## Summary of Guidelines for Maintenance Activities Required of the OPW Phase I Vapor Recovery System <sup>2</sup>

<b>Component</b>	<b>Interval<sup>2</sup></b>	<b>Maintenance To Be Performed</b>
<b>Vapor Adaptor</b> OPW 61VSA	Annual	Visually inspect the adaptor for large dents, cracks, or deformations. Check the vapor poppet for damage and ensure that the poppet seats evenly with the adaptor. Clean out any foreign objects from the vapor poppet's seal and seal surface if necessary. Test the poppet seal by applying a soap solution to the poppet while the underground storage tank is under a positive gauge pressure of at least 2.00 inches W.C and inspect for the presence of bubbles. If the facility continuously operates under vacuum, a bag test may be used by sealing a clear plastic bag to the adaptor's sides. If no bubbles appear at the poppet under positive pressure or the bag test shows no signs of the bag collapsing, no further maintenance is required. If bubbles appeared around the poppet seal or the bag collapsed, replace the poppet components and re-test. Verify the static torque of the swivel adaptor by performing California ARB test procedure TP-201.1B.
<b>Jack Screw Kit</b> OPW 61JSK OPW 71JSK	Annual	Visually inspect the Jack Screw for proper alignment and installation.
<b>Face Seal Adaptor</b> OPW FSA-400 OPW FSA-400-S	None	No maintenance is required for this product.
<b>Drop Tubes</b> OPW 61T	Annual	Visually inspect Drop Tube to see if it is installed and ensure that the bottom of tube is within 6 inches of the bottom of tank. Test the drop tube seal with ARB procedure TP-201.1C or TP-201.1D as applicable. If the drop tube seal passes testing, no further maintenance is required. If the drop tube seal fails testing, replace the drop tube seal with OPW P/N: H11931M for 4" Tubes. Re-test the drop tube seal with ARB procedure TP-201.1C or TP-201.1D as applicable.

<sup>2</sup> These maintenance requirements shall not circumvent use of the manufacturer's installation and maintenance instructions. Maintenance contractors or owner/operators shall refer to the manufacturers complete installation and maintenance instructions found herein for the OPW Phase I System to ensure that all maintenance and torque requirements are met.

<sup>2</sup> Maintenance must be conducted within the interval specified from the date of installation and at least within the specified interval thereafter.

### Summary of Guidelines for Maintenance Activities Required of the OPW Phase I Vapor Recovery System <sup>3</sup>

Component	Interval <sup>2</sup>	Maintenance To Be Performed
<b>Drop Tube Overfill Prevention Device</b> OPW 61SO	Annual	Annually, inspect the flapper in the 61SO to see that it is open by looking down the drop tube opening. Test the 61SO drop tube seals with ARB procedure TP-201.1D. If the drop tube passes testing, no further maintenance is required. If the drop tube fails testing, replace the drop tube seal with OPW P/N: H11931M for 4" Tubes. Re-test the 61SO drop tube with ARB procedure TP-201.1D. If this does not correct the leak, the 61SO needs to be replaced.
OPW 71SO/71SO Testable	Annual	Annually, inspect the flapper in the 71SO/71SO Testable to see that it is open by looking down the drop tube opening. Test the 71SO/71SO Testable drop tube seals with ARB procedure TP-201.1D. If the drop tube seal passes testing, no further maintenance is required. If the drop tube fails testing, replace the drop tube seal with OPW P/N: H11931M for 4" Tubes. Re-test the 71SO drop tube with ARB procedure TP-201.1D. The lower tube o-ring seal OPW P/N: H14840M can also be replaced. If this does not correct the leak the 71SO/71SO Testable needs to be replaced.
<b>Tank Bottom Protector</b> OPW/POMECO 6111-1400	None	No maintenance is required for this product.
<b>Tank Gauge Port Components</b> <b>OPW 62M</b> Morrison Brothers 305 Veeder-Root 312020-952	Annual	Visually inspect cap to see that it is not missing any seals and is properly installed.

<sup>3</sup> These maintenance requirements shall not circumvent use of the manufacturer's installation and maintenance instructions. Maintenance contractors or owner/operators shall refer to the manufacturers complete installation and maintenance instructions found herein for the OPW Phase I System to ensure that all maintenance and torque requirements are met.

<sup>2</sup> Maintenance must be conducted within the interval specified from the date of installation and at least within the specified interval thereafter.

**OPW  
EVR Phase I Equipment  
Installation Check List**

Site Identification Information

Site Address:

---

---

---

Installing Company: \_\_\_\_\_

Certified Technician Number: \_\_\_\_\_

Technician's Name **(Print Clearly)**: \_\_\_\_\_

Technician's Signature: \_\_\_\_\_

Date of Installation: \_\_\_\_\_



## OPW EVR Phase I Equipment Installation Check List

**Components Installed**

OPW 1-Series EVR Fill Spill Containment Bucket	Yes ___	No ___
OPW 1-Series EVR Vapor Spill Containment Bucket	Yes ___	No ___
OPW FSA-400, or FSA-400-S Threaded Riser Adaptor (Face Seal Adaptor)		
On Fill Riser (Required)	Yes ___	No ___
On Tank Probe Riser (Required)	Yes ___	No ___
On Vapor Riser (Optional)	Yes ___	No ___
OPW 61SO Series Overfill Prevention Valve	Yes ___	No ___
OPW 71SO/71SO Testable Series Overfill Prevention Valve	Yes ___	No ___
OPW 61T Series Straight Drop Tube	Yes ___	No ___
OPW 61JSK Jack Screw Assembly		
61JSK-4410 (Use with composite base spill bucket)	Yes ___	No ___
61JSK-44CB (Use with cast iron base spill bucket)	Yes ___	No ___
61JSK-4RMT (Only used on Remote-Fill Applications)	Yes ___	No ___
71JSK-44MA (For use with E85 fueling facilities)	Yes ___	No ___
71JSK-4RMT (For use with E85 fueling facilities)	Yes ___	No ___
OPW 61VSA Vapor Swivel Adaptor	Yes ___	No ___
OPW 61SALP Fill Swivel Adaptor	Yes ___	No ___
OPW 634TT Top Seal EVR Fill Cap	Yes ___	No ___
OPW 1711T Top Seal EVR Vapor Cap	Yes ___	No ___
OPW 634LPC Low Profile Top Seal EVR Fill Cap	Yes ___	No ___
OPW 1711LPC Low Profile Top Seal EVR Vapor Cap	Yes ___	No ___
CompX CSP1-634LPC TuBAR Tank Commander Fill Cap	Yes ___	No ___
CompX CSP3-1711LPC TuBAR Tank Commander Vapor Cap	Yes ___	No ___
CompX CSP2-634LPC Padlock Tank Commander Fill Cap	Yes ___	No ___
CompX CSP4-1711LPC Padlock Tank Commander Vapor Cap	Yes ___	No ___
OPW 233 Extractor	Yes ___	No ___
OPW 53VML Ball Float Vent Valve	Yes ___	No ___
OPW 30MV Ball Float Vent Valve	Yes ___	No ___
OPW 62M Monitoring Probe Caps	Yes ___	No ___

**Installation Acknowledgment**

Installed OPW FSA-400 (-S) Threaded Riser Adaptor (Face Seal Adaptor) on fill riser and tightened to \_\_\_\_\_ ft. lb.  
 Thread sealant compound used \_\_\_\_\_

Installed OPW FSA-400 (-S) Threaded Riser Adaptor (Face Seal Adaptor) on tank probe riser and tightened to \_\_\_\_\_ ft. lb.  
 Thread sealant compound used \_\_\_\_\_

**Optional**

Installed OPW FSA-400 (-S) Threaded Riser Adaptor (Face Seal Adaptor) on vapor riser and tightened to \_\_\_\_\_ ft. lb.  
 Thread sealant compound used \_\_\_\_\_

Installed OPW 2100 Series \_\_\_\_\_, 3100 Series \_\_\_\_\_, or 500 Series \_\_\_\_\_ Fill spill containment bucket onto FSA-400 attached to fill riser and tightened to \_\_\_\_\_ ft. lb.  
 Thread sealant compound used \_\_\_\_\_

Installed OPW 2100 Series \_\_\_\_\_, 3100 Series \_\_\_\_\_, or 500 Series \_\_\_\_\_ vapor spill containment bucket onto vapor riser and tightened to \_\_\_\_\_ ft. lb.

Thread sealant compound used \_\_\_\_\_

Assembled OPW 61SO Series overfill prevention valve

Used OPW supplied epoxy Yes \_\_\_ No \_\_\_

Applied epoxy: To upper 1" inside of top tube, under cinch head bolts and lock washers, on threads of valve body at lower tube connection. Yes \_\_\_ No \_\_\_

Allowed epoxy to cure for 24 hours before exposure to fuel or vapor Yes \_\_\_ No \_\_\_

Installed OPW 61SO Series overfill prevention valve into fill spill containment bucket.

Yes \_\_\_ No \_\_\_

Assembled OPW 71SO/71SO Testable Series overfill prevention valve Yes \_\_\_ No \_\_\_

Installed OPW 71SO/71SO Testable Series overfill prevention valve into fill spill containment bucket

Yes \_\_\_ No \_\_\_

**Alternative to 61SO**

Installed OPW 61T Straight Drop Tube into fill spill containment bucket. Yes \_\_\_ No \_\_\_

Installed OPW 61JSK Jack Screw assembly on top of 61SO Series overfill prevention valve or on top of 61T Series Straight Drop Tube. Yes \_\_\_ No \_\_\_

Lock-Tite applied to screws Yes \_\_\_ No \_\_\_

Screws tightened to \_\_\_\_\_ ft. lb.

Installed faced off 4" NPT pipe nipple in fill spill containment bucket and tightened nipple to \_\_\_\_\_ ft. lb.

Thread sealant compound used \_\_\_\_\_

Tool used to install nipple \_\_\_\_\_

Installed faced off 4" NPT pipe nipple in vapor spill containment bucket and tightened nipple to \_\_\_\_\_ ft. lb.

Thread sealant compound used \_\_\_\_\_

Tool used to install nipple \_\_\_\_\_

Installed OPW 61 SALP Fill Swivel Adaptor onto faced off 4" NPT pipe nipple in fill spill containment bucket and tightened fill adaptor to \_\_\_\_\_ ft. lb.

Thread sealant compound used \_\_\_\_\_

Tool used to install nipple \_\_\_\_\_

Installed OPW 61 VSA Vapor Swivel Adaptor onto faced off 4" NPT pipe nipple in vapor spill containment bucket and tightened vapor adaptor to \_\_\_\_\_ ft. lb.

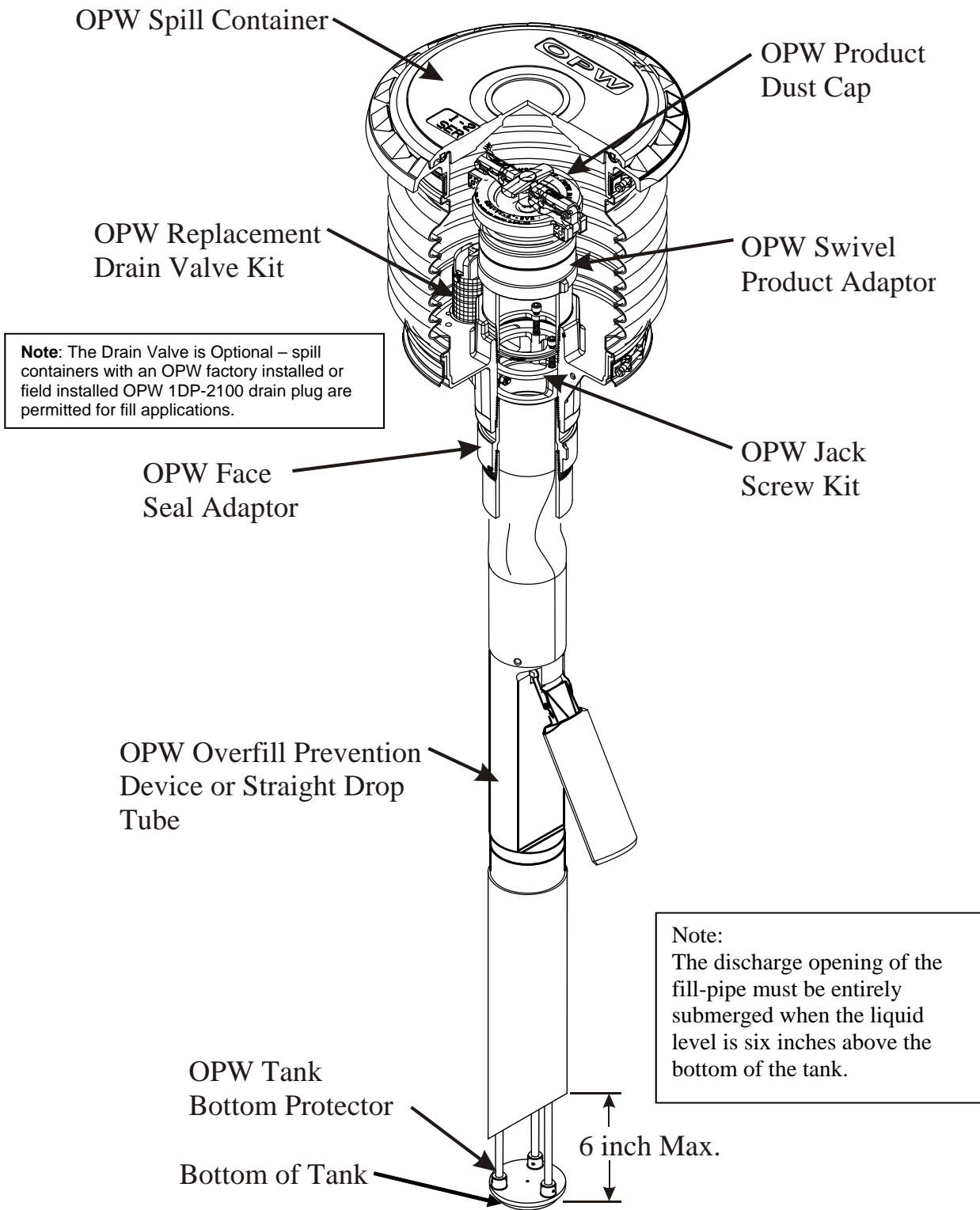
Thread sealant compound used \_\_\_\_\_

Tool used to install nipple \_\_\_\_\_

OPW 61 SA-Tool used to install OPW components Yes \_\_\_ No \_\_\_

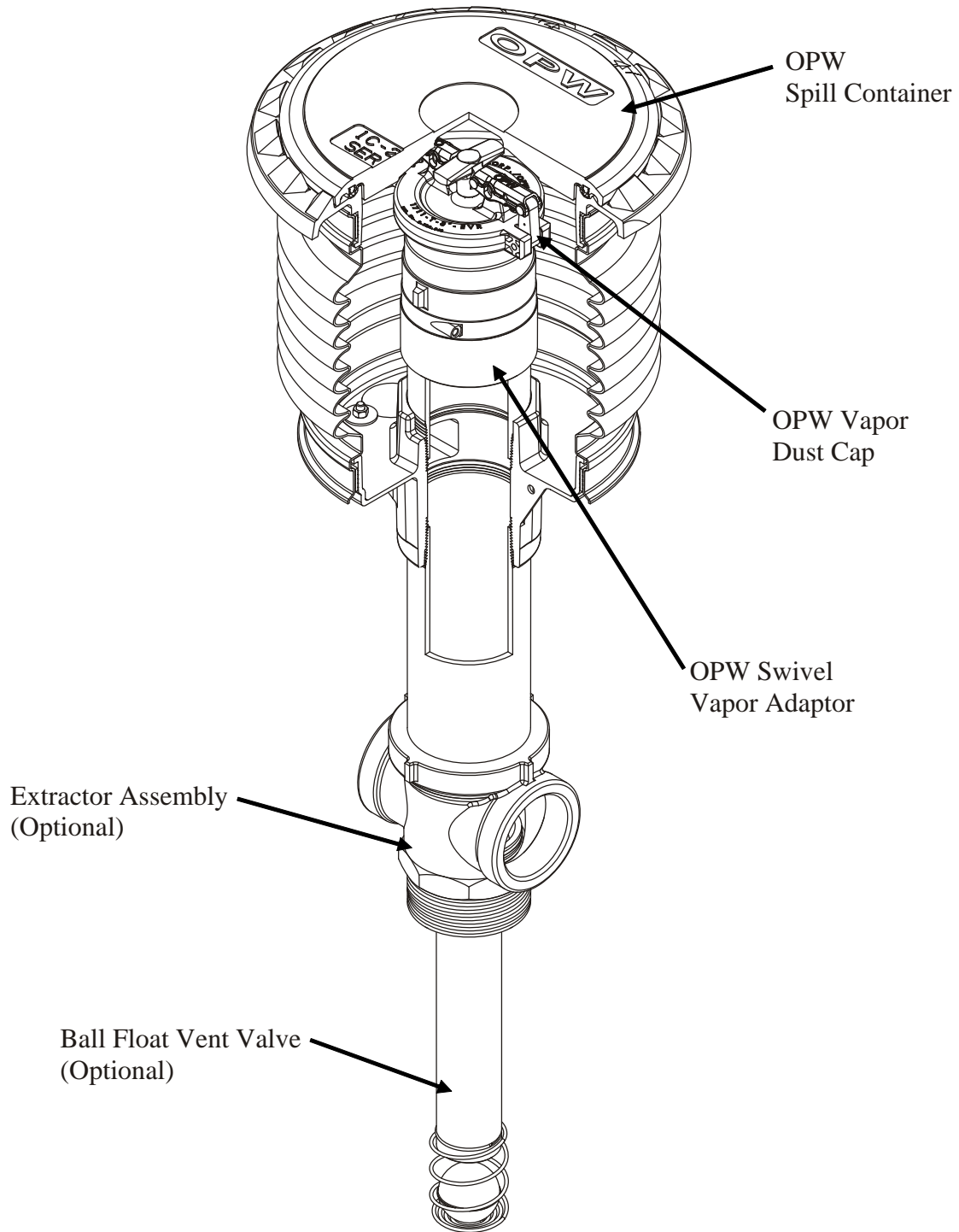
---

### Typical Product Installation Using OPW System<sup>4</sup>

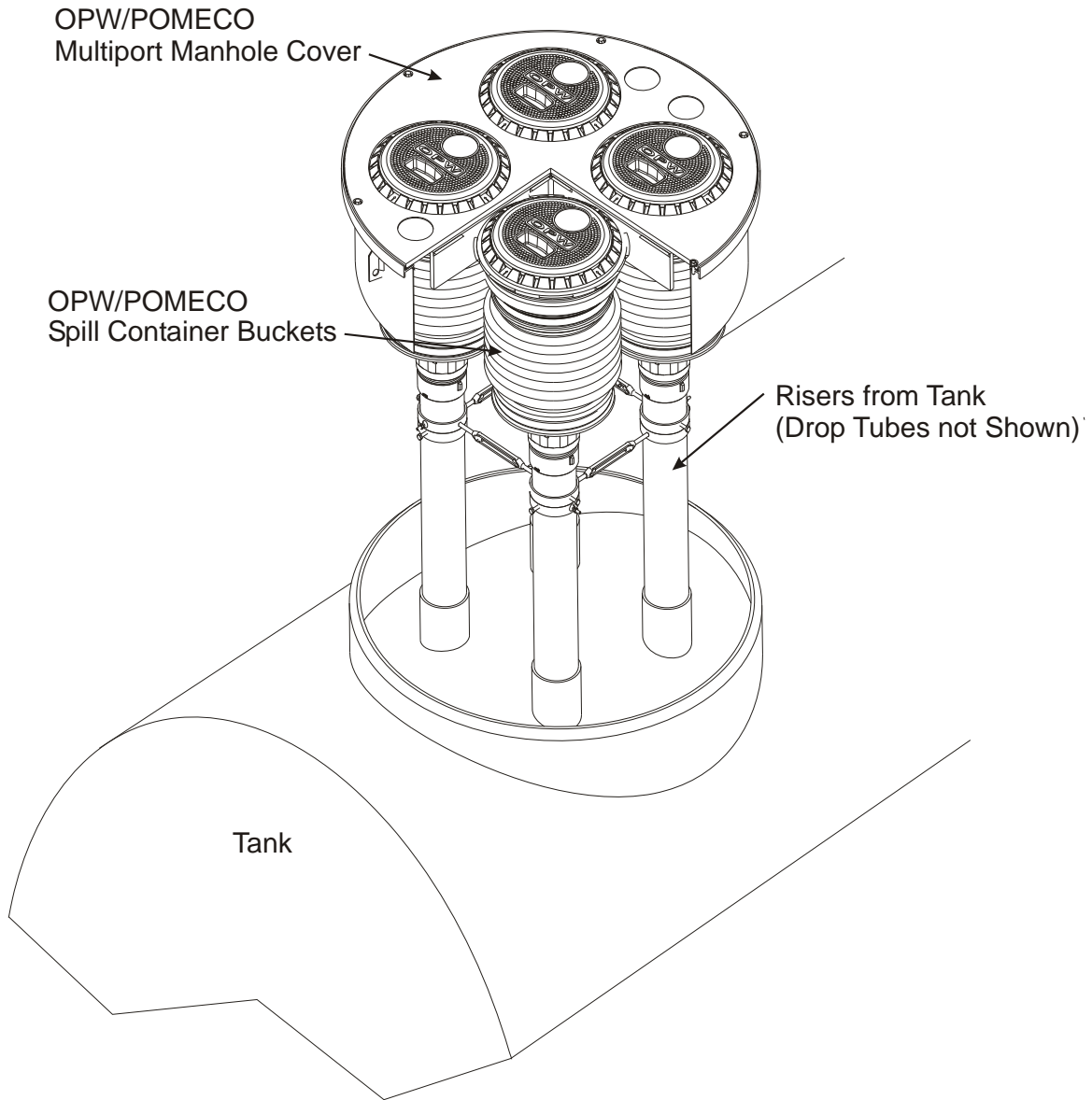


<sup>4</sup> McGard FL1 or FL2 Fuel Lock (Optional - Not Pictured), if installed, would be positioned inside the riser seal (or pipe nipple) below the rotatable adaptor.

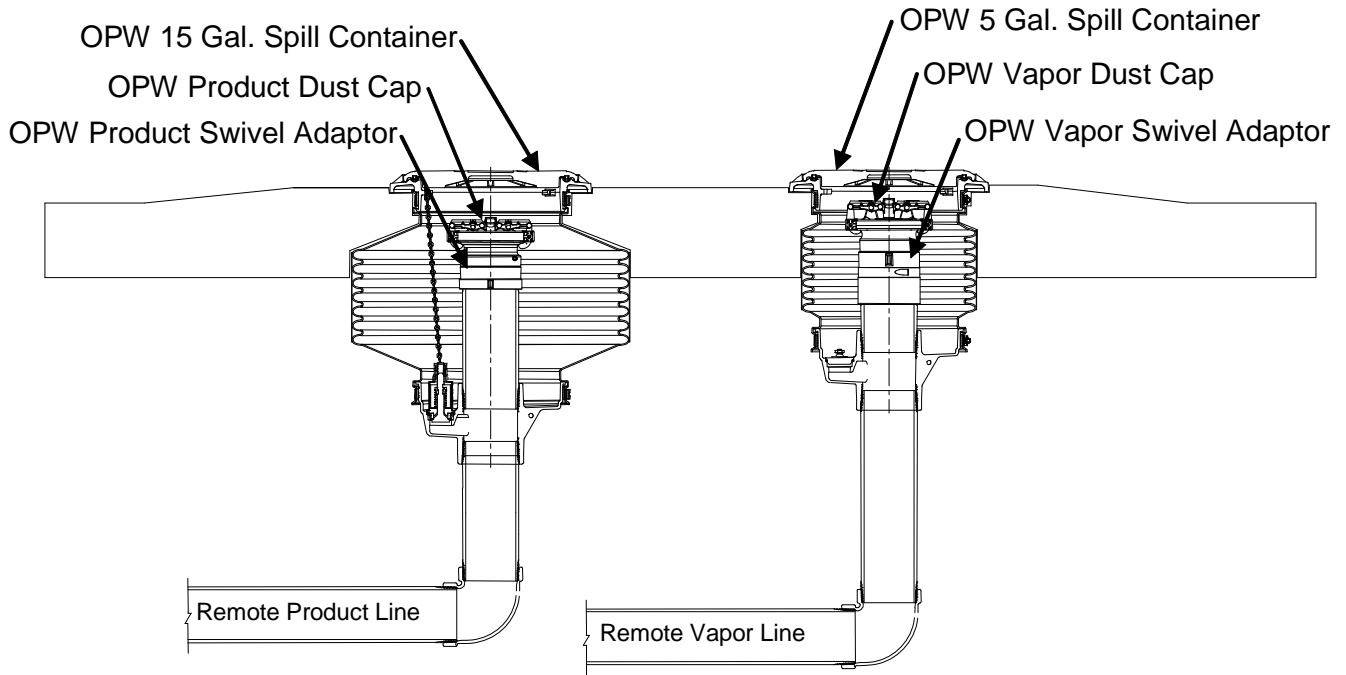
### Typical Vapor Installation Using OPW System



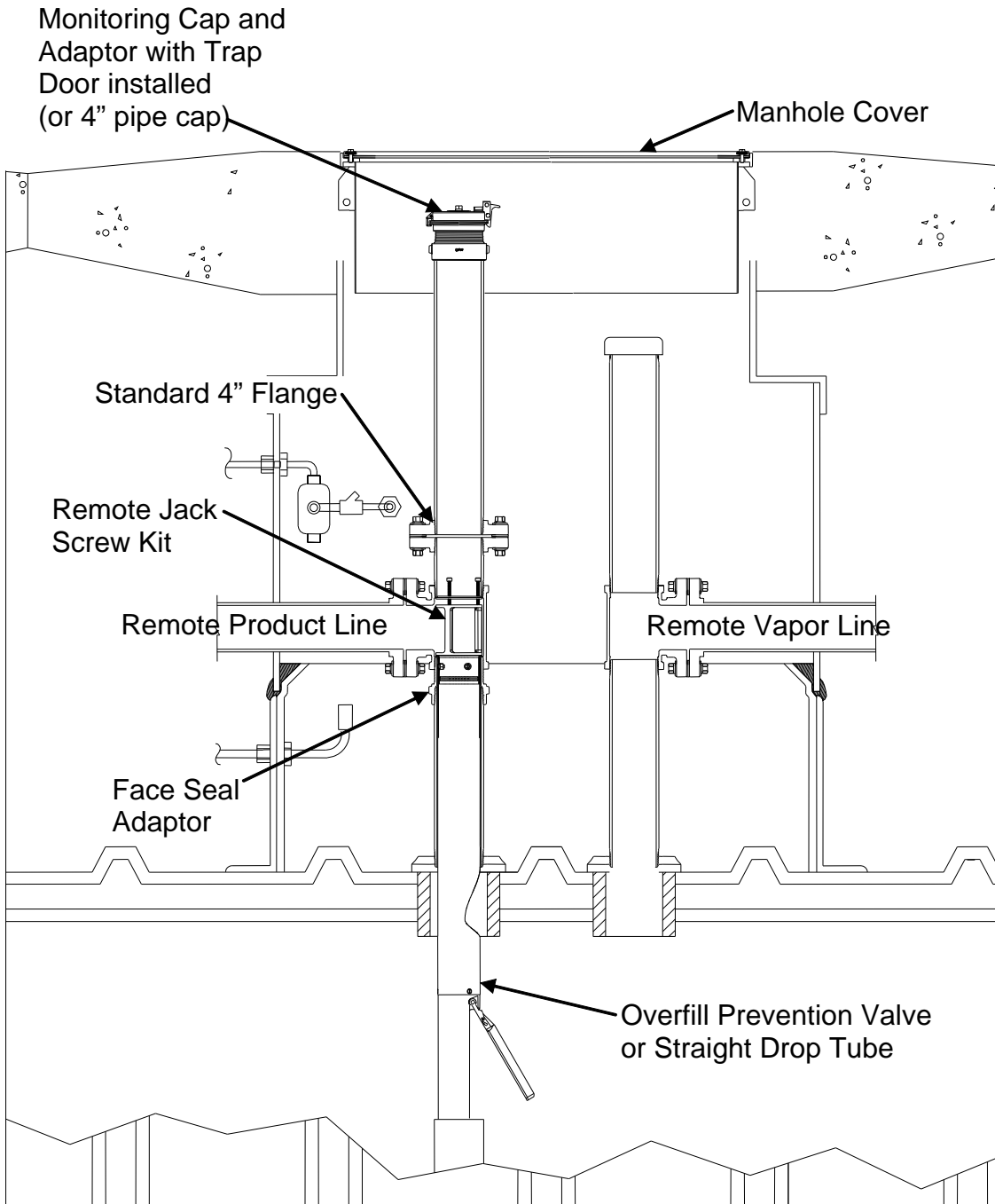
### Typical OPW/POMECO Double Fill Configuration



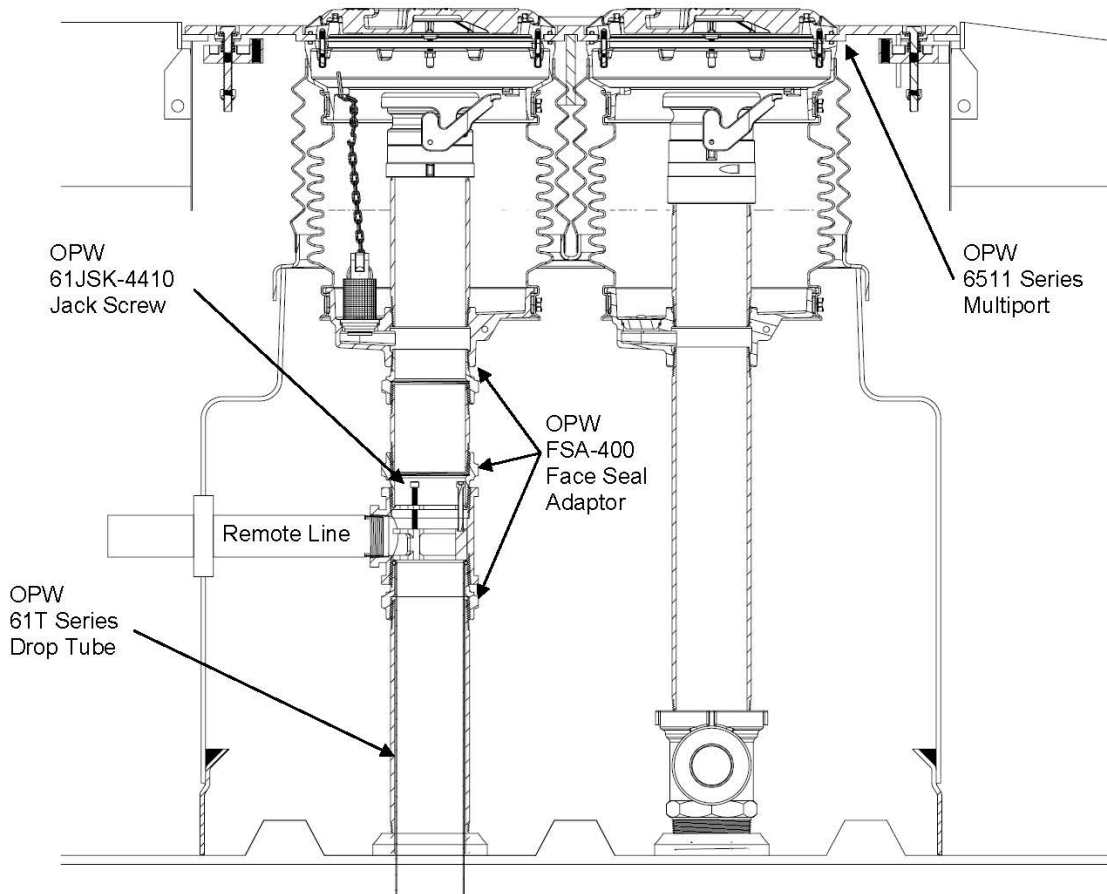
### Typical OPW Remote-Fill Access Point Configuration



### Typical OPW Remote-Fill Tank Top Configuration



### Typical OPW Remote Fuel Additive Configuration







## Installation and Maintenance Instructions OPW 1-2100 Series Thread-On Grade Level Spill Containers

**IMPORTANT:** Please read these warnings and assembly instructions completely and carefully before starting. Failure to do so may cause product failure, or result in environmental contamination due to liquid leakage into the soil, creating hazardous spill conditions.

**IMPORTANT:** The OPW 1-2100 Spill Container is pre-assembled for your convenience and ease of installation. Check to make sure the unit is intact and undamaged and all parts have been supplied. Never substitute parts for those supplied. Doing so may cause product failure.

**WARNING-DANGER:** Using electrically operated equipment near gasoline or gasoline vapors may result in a fire or explosion, causing personal injury and property damage. Be sure that the working area is free from such hazards, and always use proper precautions.

**NOTE:** At all times when product is in the storage tank keep the riser pipe capped, so the vapors cannot escape into the environment.

**Notice:** FlexWorks by OPW, Inc., VAPORSAVER™ and all other OPW products must be used in compliance with all applicable federal, state, provincial and local laws, rules and regulations. Product selection is the sole responsibility of the customer and/or its agents and must be based on physical specifications and limitations, compatibility with the environment and material to be handled. All illustrations and specifications in this literature are based on the latest production information available at the time of publication. Prices, materials and specifications are subject to change at any time, and models may be discontinued at any time, in either case, without notice or obligation.

This section intentionally left blank

**1-2100 Series Performance Specifications:**

This Spill Container drain valve has been manufactured and tested to the following California specifications: Leak Rate to be less than or equal to 0.17 CFH @ 2.0 " W.C.

**Torque Specification:**

**Spill Container 4" NPT**, 125 ft-lbs minimum to 250 ft- lbs maximum.

**4" Nipple, 4" NPT**, 125 ft-lbs minimum to 250 ft-lbs maximum.

**Drain Valve clamps:** 5/16-18 UN thread, 11.5 ft-lbs minimum to 13.5 ft-lbs maximum.

**OPW No. 1-2100 SERIES GRADE LEVEL SPILL CONTAINER INSTALLATION INSTRUCTIONS**

**Step 1:**

Per California SB-989, all metal must be protected from direct contact with the elements. Coat stainless steel band clamps with the following approved coatings. OPWSL-1100, 3M Underseal 08883 or Polyguard Mastic CA-9. Only the threaded hardware needs to be coated in the field.

**Step 2:** (See Figure 1 & 2)

Set riser pipe. "L" is the distance between the top of the riser pipe and finish grade.

<u>Model Series</u>	<u>"L" Dimension</u>
1-2100, 5 Gal. (Comp. Base)	L=15" (40cm)
1-2100E, 7.5 Gal (Comp. Base)	L=21" (50cm)
1-2115, 15 Gal. (Comp. Base)	L=20" (51cm)
1-2100C, 5 Gal (Cast Iron Base)	L=14 1/2" (37cm)
1-2100EC, 7.5 Gal (Cast Iron Base)	L=18 1/2" (47cm)
1-2115C, 15 Gal (Cast Iron Base)	L=18 1/2" (47cm)

**Note: The "L" dimensions below factors in a 1" slope to grade.**

**NOTE: If using OPW FSA-400, add 3-1/4" to Dimension "L". If using OPW FSA-400-S, add 1-3/4 to Dimension "L".**

**NOTE: FSA-400-S will only work with Cast Iron Base.**

**Step 3:**

Deburr and thoroughly clean riser pipe. Apply pipe dope to riser threads. Pipe dope to be a non-

This section intentionally left blank.

**\*\* Date of manufacture on this product is located on the mounting ring of the bucket.**

In California it is prohibited to use spill container drain valves on spill containers that are exclusively used for vapor return risers. Install only 1-2100 Series Thread-On spill container models equipped with a drain plug.

hardening, gasoline resistant pipe thread seal compound.

**Step 4:**

Install OPW FSA-400 Face Seal Adapter onto riser using the OPW 61SA-TOOL. Torque to 125 ft-lbs min. to 250 ft-lbs max. (4" NPT). Apply pipe dope to FSA-400. Pipe dope should be a non-hardening, gasoline resistant pipe thread seal compound.

**Step 5:**

Install spill container by rotating the mounting ring until hand tight.

**NOTE: Do not attempt to completely tighten the container by using the mounting ring.**

**Step 6:**

Finish tightening the spill container with the OPW 61SA-TOOL. Torque to 125 ft-lbs min. to 250 ft. Lbs. max. (4" NPT)

**NOTE: Ground riser pipe to nearest grounding rod.**

**Step 7:** (See Figure 2)

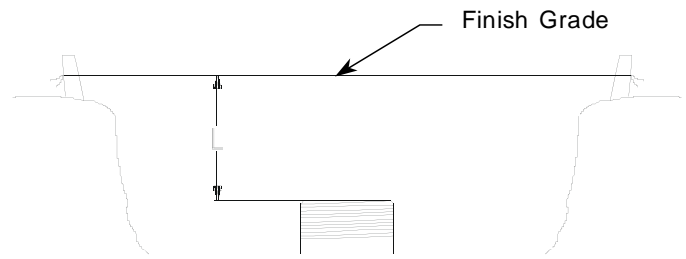
Apply pipe dope to nipple and install. Pipe dope to be a non-hardening, gasoline resistant pipe thread seal compound. Use only factory made nipples. Nipples must be cut square and deburred. Torque to 125 ft-lbs min. to 250 ft-lbs max. (4" NPT). Torque value is based on rotation at the center of pipe. For standard cover models install adaptor and dust cap. For sealable cover (1SC) models, install a standard 4" pipe cap to support adjustment system. (Adaptor and dust cap must be installed in sealable cover (SC) models after concrete has dried.

**NOTE: Nipple length is determined by measuring from the bottom of the threaded portion of the base to the bottom of the cover. Then subtract 2" for clearance, height of adaptor and height of cap. Range of nipple lengths that can be used in all of the OPW spill containers: 4" minimum to 14" maximum.**

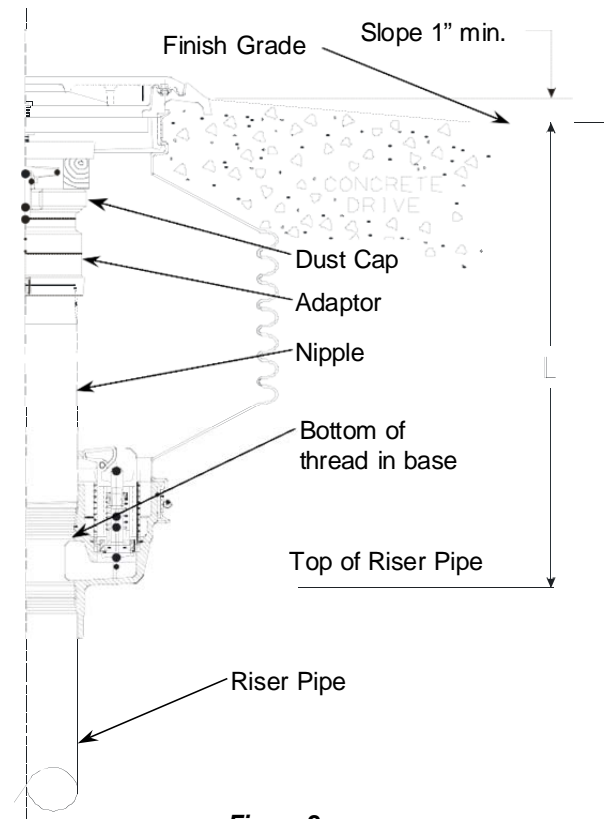
**Step 8:** (See Figure 3 & 4)

Install adjusting system (sold separately, part number H12267) beneath tabs on mounting ring. See Figure 3 for standard cover models. See Figure 4 for sealable cover models. Add shims as needed and adjust with screw. (Shims must be cut to size for sealable cover models.) The height can be increased up to 1" (2.5cm).

**NOTE: The adjustment should not be more than 1" from the initial length of the unit.**



**Figure 1**



**Figure 2**

**Step 9:**

Upon preliminary installation perform the California Test Procedures TP-201.1C or equivalent. Their Test Procedures will check the seals between the drain valve, nipple and rotatable adapter. To test the spill containers base and bellows fill the container with water. A drop in the water level of 1/16" or greater after one hour means that a leak exists. To determine where the leak is, look for a steady stream of bubbles coming from one of the joints or water leaking on the outside of the bucket. **NOTE: Do not drain the water into the UST after the test is complete. Water must be disposed of per local requirements for hazardous waste. If the leak cannot be corrected the spill container should be replaced with another.**

**Step 10:** (See Figure 2)

Before pouring concrete, place plastic over the cover and mounting ring protecting them from concrete

splash. Double check that the unit is level and at proper grade height. Pour concrete per figure 2. Ramp or dome the concrete away from the mounting ring. There should be a minimum of 1" slope to finish grade. The concrete surface should start at the bottom edge of the watershed slots and tapered down to grade level.

**NOTE: Do not stand on spill container before concrete sets up.**

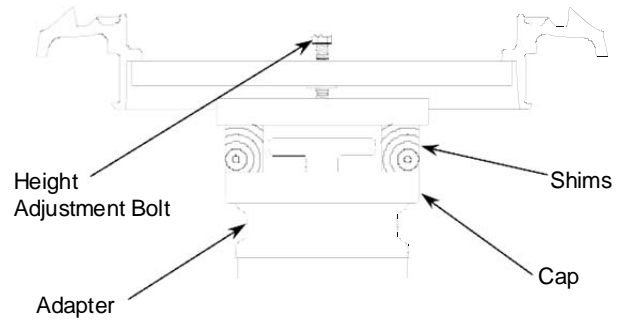
Remove plastic from cover after concrete has dried. Remove adjustment system. Adaptor and tight fill cap can now be installed in sealable cover models. Re-test the spill containers for leaks as described in step 9, after the concrete has set up.

**OPERATION AND MAINTENANCE:**

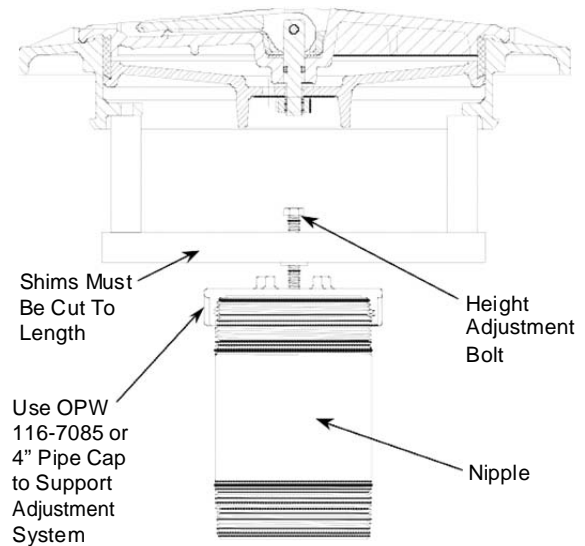
**Annually:** Inspect and clean the interior of the spill container and drain valve screen. Remove accumulated dirt and grit. Test the drain valve using CARB procedure TP-201.1C or TP-201.1D. If the drain valve passes testing no further maintenances

required. If the drain valve fails testing, remove the valve, soak in water and use high-pressure air, if needed, to clean. Reinstall the drain valve to its proper position and test the valve with CARB procedure TP-201.1C or TP-201.1D. If problems persist, replace the drain valve with P/N 1DK-2100-EVR (specified torque 11.5 ft-lbs min to 13.5 ft-lbs max, 5/16-18 UN thread). The sealable cover (1SC) adjustment nut is set at the factory, but due to environmental conditions it may be necessary to adjust it to either improve sealing or ease cover removal.

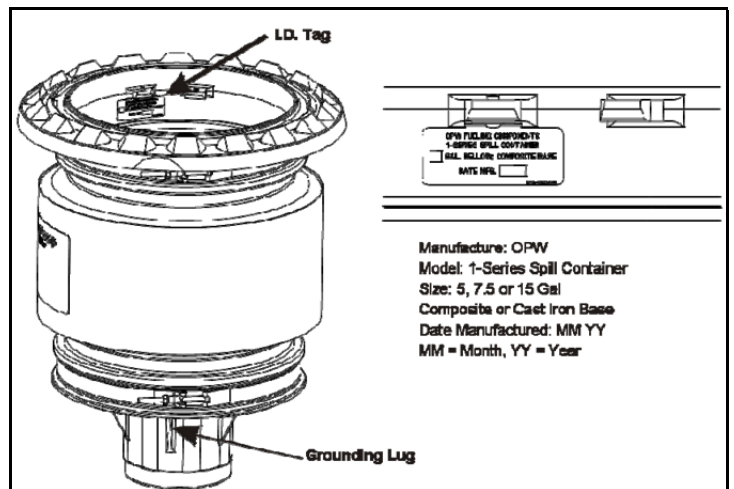
**IMPORTANT: Leave these instructions with the Station Operator.**



**Figure 3 - Standard Cover Model Height Adjustment**



**Figure 4 - Sealable Cover Model Height Adjustment**



3250 US 70 Business West  
 Smithfield, NC 27577  
 Customer Service: 1-(800) 422-2525  
 Technical Service and Questions:  
 1-(877) OPW-TECH  
 www.opwglobal.com





## OPW 1-2200 Series Thread-On Single Wall Grade Level Spill Containers with Replaceable Bellows Installation and Maintenance Instructions

Please read these warnings and assembly instructions completely and carefully before starting. Failure to do so may cause product failure, or result in environmental contamination due to liquid leakage into the soil, creating hazardous spill conditions.

**IMPORTANT:** The OPW 1-2200 Spill Container is preassembled for your convenience and ease of installation. Check to make sure the unit is intact and undamaged and all parts have been supplied. Never substitute parts for those supplied. Doing so may cause product failure.

**WARNING-DANGER:** Using electrically operated equipment near gasoline or gasoline vapors may result in a fire or explosion, causing personal injury and property damage. Be sure that the working area is free from such hazards, and always use proper precautions.

**NOTE:** Keep the riser pipe capped at all times when product is in the storage tank, so the vapors cannot escape into the environment.

**Notice:** OPW products must be used in compliance with applicable federal, state, and local laws and regulations. Product selection should be based on physical specifications and limitations and compatibility with the environment and material to be handled. All illustrations and specifications in this literature are based on the latest production information available at the time of publication. Prices, materials, and specification are subject to change at any time, and models may be discontinued at any time, in either case, without notice or obligation.

### OPW STANDARD PRODUCT WARRANTY TAG

Notice: FlexWorks by OPW, Inc., VAPORSAVER™ and all other OPW products must be used in compliance with all applicable federal, state, provincial and local laws, rules and regulations. Product selection is the sole responsibility of the customer and/or its agents and must be based on physical specifications and limitations, compatibility with the environment and material to be handled. All illustrations and specifications in this literature are based on the latest production information available at the time of publication. Prices, materials and specifications are subject to change at any time, and models may be discontinued at any time, in either case, without notice or obligation.

OPW warrants solely to its customer (the initial purchaser and any subsequent purchasers within the warranty period) that the following products sold by OPW will be free from defects in materials and workmanship under normal use and conditions for the periods indicated:

PRODUCT	WARRANTY PERIOD
FlexWorks Primary Pipe	10 years from date of manufacture
All Products and replacement parts installed in the State of California Certified to California CP-201 and/or CP-206 Standards*	1 year from date of installation (proof of purchase from certified contractors/technicians required) OPW warrants ongoing compliance with the standards and specifications for the duration of the warranty period required by the State of California; this limited warranty is under the condition the equipment was installed and maintained by trained and certified contractors/technicians unless noted in Installation Manual.
All other Products and replacement parts	1 year from date of manufacture**
*Products certified to California CP-201 and/or CP-206 Standards have been factory tested and met all applicable performance standards and specifications and will have an OPW registration card enclosed/attached to the product.	

OPW's exclusive obligation under this limited warranty is, at its option, to repair, replace or issue credit (in an amount not to exceed the list price for the product) for future orders for any product that may prove defective within the applicable warranty period. (Parts repaired or replaced under warranty are subject to prorated warranty coverage for remainder of the original warranty period). Complete and proper warranty claim documentation and proof of purchase required. All warranty claims must be made in writing and delivered during the applicable warranty period to OPW at OPW 9393 Princeton-Glendale Road Hamilton, Ohio, USA 45011, Attention: Customer Service Manager. No products may be returned to OPW without its prior written authority.

This limited warranty shall not apply to any FlexWorks or VAPORSAVER™ product unless it is installed by an OPW attested installer and all required site and warranty registration forms are completed and received by OPW within 60 days of installation. This limited warranty also shall not apply to any FlexWorks, VAPORSAVER™ or other OPW product: unless all piping connections are installed with a nationally-recognized or state-approved leak detection device in each tank and dispenser sump (which are not for storage and from which all discharge hydrocarbons must be removed, and the systems completely cleaned, within 24 hours); unless testable sumps utilize FlexWorks pipe and access fittings; unless a sump inspection log or an EPA recommended/required checklist is maintained and the results are furnished to OPW upon request; and unless OPW is notified within 24 hours of any known or suspected product failure and is provided with un-

restricted access to the product and the site. This limited warranty also shall not apply to any product which has been altered in any way, which has been repaired by anyone other than a service representative authorized by OPW, or when failure or defect is due to: improper installation or maintenance (including, without limitation, failure to follow Flex-Works Quick Reference Manual Installation Guide and all product warning labels); abuse or misuse; violation of health or safety requirements; use of another manufacturer's, or otherwise unauthorized, substances or components; soil or other surface or subsurface conditions; or fire, flood, storm, lightning, earthquake, accident or any other conditions, events or circumstances beyond OPW's control.

THIS LIMITED WARRANTY IS IN LIEU OF ALL OTHER WARRANTIES, EXPRESS OR IMPLIED, AND ALL OTHER WARRANTIES INCLUDING, WITHOUT LIMITATION, THE WARRANTIES OF MERCHANTABILITY AND FITNESS FOR A PARTICULAR PURPOSE, ARE HEREBY EXCLUDED.

OPW shall have no other liability whatsoever, whether based on breach of contract, negligence, gross negligence, strict liability or any other claim, including, without limitation, for special, incidental, consequential or exemplary damages or for the cost of labor, freight, excavation, clean-up, downtime, removal, reinstallation, loss of profit, or any other cost or charges. No person or entity is authorized to assume on behalf of OPW any liability beyond this limited warranty. This limited warranty is not assignable.

**\*\* Date of manufacture on this product is located on the inner ring of the bucket.**

In some states it is prohibited to use spill container drain valves on spill containers that are exclusively used for vapor return risers. Install only 1-2200 Series Thread-On spill container models equipped with a drain plug.

**WARNING:** If the inner ring, lower bellows ring, bellows, or base is removed for any reason, follow the Operation and Maintenance instruction as noted. Replace o-rings and seals and install new ones. Never reuse damaged o-rings or seals as it may result in an improper seal. Only qualified, competent, well-trained technicians should perform maintenance. Common sense and good judgment should always be exercised. The contractor's understanding of all related site conditions prior to starting the project is essential. If the contractor does not have a clear understanding of the required work and site conditions, the contractor is advised to seek clarification prior to starting any portion of the project.

**NOTICE TO DELIVERY DRIVER:** All delivery drivers MUST inspect the inside of the container for water or contaminants other than fuel prior to delivery. If water or contaminants are present, then they MUST be removed before proceeding. Dispose of towels and debris safely and per all applicable local, state, and federal codes. After delivery is complete, the driver MUST drain any excess fuel that may have spilled into the container from their delivery hose.

**1-2200 Series Performance Specifications:** This Spill Container drain valve has been manufactured and tested to the following specifications: Leak Rate to be less than or equal to 0.17 CFH @ 2.0 " W.C.

**Torque Specification:**

Spill Container 4" NPT, 125 ft-lbs minimum to 250 ft-lbs maximum.

4" Nipple: 4" NPT, 125 ft-lbs minimum to 250 ft-lbs maximum.

**NOTE: All 4" NPT threads are to be torqued progressively lower from the tank up.**

Drain Valve clamps: 5/16-18 UN thread, 11.5 ft-lbs minimum to 13.5 ft-lbs maximum.

Nipple Adaptor Bolts: 3/8-16 UN, 20 ft-lbs minimum to 25 ft-lbs maximum.

Inner Ring and Lower Bellows Ring Bolts: 3/8 - 16 UN, 15 ft-lbs minimum to 20 ft-lbs maximum.

**Tools Recommended:**

1-3100-TOOL - Torque Installation Tool

DW-VAC-TEST - Vacuum Test Equipment

SC-TEST-Sealable Test Cover

**OPW 1-2200 SERIES GRADE LEVEL SPILL CONTAINER INSTALLATION INSTRUCTIONS:**

**Step 1:** (See Figures 1 and 2)

Determine riser pipe height. "L" is the distance between the top of the riser pipe and finish grade.

**NOTE: The spill container height (from riser to grade) is L + 1".**

Model Series	"L" Dimension
5 Gal. (Cast Iron Base)	L = 15 5/8" (40 cm)
15 Gal. (Cast Iron Base)	L = 17 3/8" (44 cm)

**Step 2:**

De-burr and thoroughly clean riser pipe. Apply pipe dope to riser threads. Pipe dope is to be a non-hardening, gasoline resistant pipe thread seal compound.

**NOTE: Ground riser pipe to nearest grounding rod.**

**Step 3:**

Install spill container by rotating the mounting ring until hand tight.

**NOTE: Do NOT attempt to completely tighten the container using the mounting ring. Doing so may cause the unit to fail.**

**Step 4: (See Figure 2)**

Finish tightening the spill container base using the wrenching boss or with the 1-3100-TOOL. Torque to 125 ft-lbs min. to 250 ft-lbs max (4" NPT). 1-3100-TOOL can be used to set final torque (see 1-3100-TOOL instructions). **NOTE:** Per PEI RP100 Section 5.11, support the spill container after installing before backfilling.

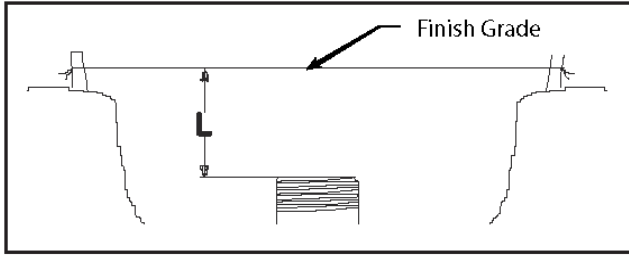


Figure 1

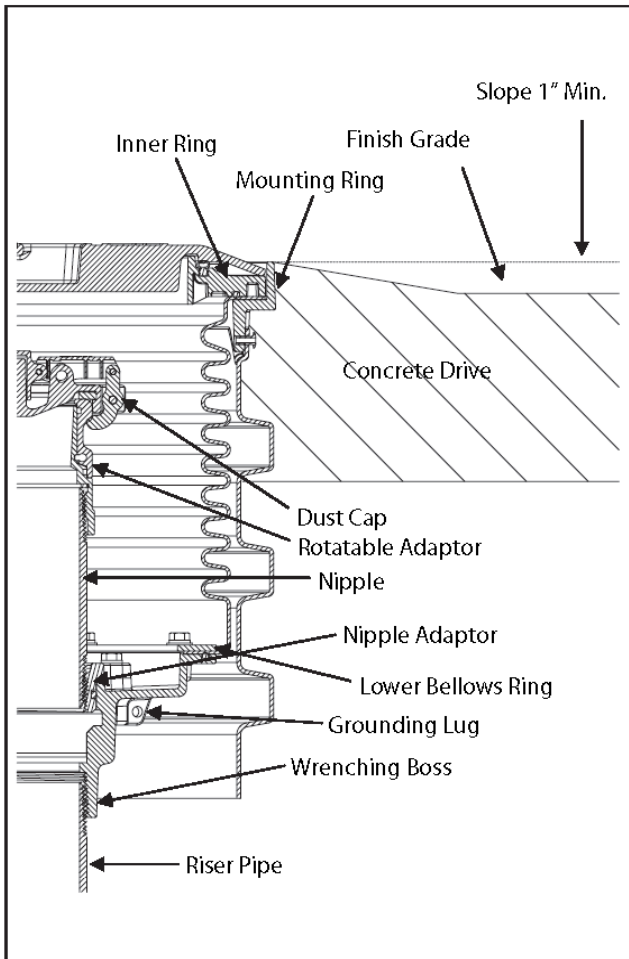


Figure 2

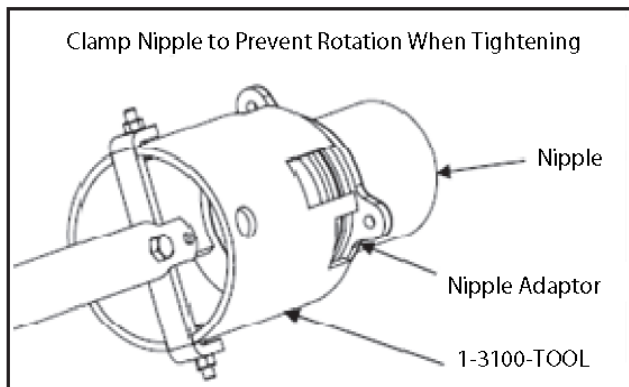


Figure 3

**Step 5: (See Figures 2 & 3)**

Remove Nipple Adaptor from spill container. Apply pipe dope to nipple and install in Nipple Adaptor. Pipe dope is to be a non-hardening, gasoline resistant pipe thread seal compound. Use only factory made nipples. Torque nipple to 125 ft-lbs min. to 250 ft-lbs max. (4" NPT). 1-3100-TOOL can be used to set final torque. Torque value is based on rotation at the center of pipe. For standard covers install rotatable adaptor and dust cap per manufacturers' instructions. For sealable cover (ISC) models, install a standard 4" pipe cap to support adjustment system. (Adaptor and dust cap must be installed in sealable cover (SC) models after concrete has dried. Install drop tube, overfill prevention valve and/or loose jack screw assembly if used (61JSK-44CB) per manufacturers' instructions. Reinstall the Nipple Adaptor in spill container. Torque Nipple Adaptor bolts to 20 ft-lbs minimum to 25 ft-lbs maximum.

**NOTE: Nipple length is determined by measuring from the bottom of the threaded portion of the base to the bottom of the cover. Then subtract 2" minimum for clearance, height of adaptor and height of cap. Range of nipple lengths that can be used in all of the OPW spill containers: 4" min to 9" max. (See Figure 6)**

**Step 6: (See Figures 4 & 8)**

If necessary, the height of the spill container can be adjusted by ±1.5" (3.8cm). If it is necessary to increase height, install adjusting system (sold separately for 5 gallon models, part number H12267) beneath tabs on mounting ring. See Figure 4 for standard cover models and Figure 8 for sealable cover models. Add shims as needed and adjust with screw (shims must be cut to size for sealable cover models).

**NOTE: The adjustment should not be more than 1.5" from the initial length of the unit.**

**Step 7:**

Where applicable, upon preliminary installation perform the CARB Test Procedure TP-201.1C or equivalent. This Test Procedure will check the seals between the drain valve, nipple, bases, and rotatable adapter.

**NOTE: Follow all state and local required testing on the primary and secondary buckets.**

**Step 8: (See Figure 7)**

Verify torque on mounting ring bolts. Torque to be 15 ft-lbs minimum to 20 ft-lbs maximum.

Perform a hydrostatic test on the spill container. To test the spill container base and bellows, fill the container with water. A drop in the water level of 1/8" or greater after one hour means that a leak exists. To determine where the leak is, look for a steady stream of bubbles coming from one of the joints or water leaking on the outside of the bucket. **NOTE: Do not drain the water into the UST after the test is complete. Water must be disposed of per local requirements for hazardous**



**waste. If the leak cannot be corrected the spill container or bellows should be replaced.**

As an alternate to a hydrostatic test a vacuum test can be performed on the spill container. Using OPW DW-VAC-TEST and SC-TEST, perform a vacuum test on the spill container. An initial vacuum of 15" of water should be attained and the spill container must retain a vacuum of at least 12" of water after 5 minutes. (See DW-VAC-TEST Instructions.)

**Step 9: (See Figures 2 & 5)**

Before pouring concrete, place plastic over the cover and Mounting Ring protecting them from concrete splash. Double check that the unit is level and at proper grade height. Pour concrete per Figure 5. Ramp or dome the concrete away from the mounting ring.

There should be a minimum of 1" slope to finish grade.

**NOTE: Do not stand on spill container before concrete sets up.**

Remove plastic from cover after concrete has dried. Remove adjustment system. Re-test the spill containers for leaks as described in Step 8, after the concrete has set up.

**Operation and Maintenance:**

After each fuel delivery, the operator must remove any standing fuel from the container. Fuel can be removed by actuating the drain valve or with a gasoline absorbing disposable towel. If access to drop tube or overfill valve is required remove Nipple Adaptor from primary bucket.

**Weekly:** Perform a visual inspection of the interior of the containment bucket for water or other contaminants. If water or other contaminants are found they must be disposed of with disposable towels. Dispose of towels safely and per all applicable local, state and federal codes. Check that cover is in good condition and properly identified. Replace cover and seal as necessary. Inspect the bucket walls for cracks, bulges or holes. If any exist, have that spill container barricaded and contact maintenance personnel immediately for repairs.

**NOTE: The bellows and base on the spill container can be replaced if damaged.**

**Semiannually:** Follow all state and local required hydrostatic or vacuum testing on the buckets. Inspect and clean the interior of the spill container and drain valve screen. Remove accumulated dirt and grit. Where applicable, test the drain valve using CARB procedure TP-201.1C or TP-201.1D. If the drain valve passes testing no further maintenances required. If the drain valve fails testing, remove the valve, soak in water and use high-pressure air, if needed, to clean. Reinstall the drain valve to its proper position and where applicable, test the valve with CARB procedure TP-201.1C or TP-201.1D. If problems persist, replace the drain valve with P/N 1DK-2100-EVR (specified torque 11.5 ft-lbs min to 13.5 ft-lbs max, 5/16-18 UN thread). The sealable cover (1SC) adjustment nut is set at the factory, but due to environmental conditions it may be necessary to adjust it to either improve sealing or ease cover removal.

**IMPORTANT: Leave these instructions with the Station Operator.**

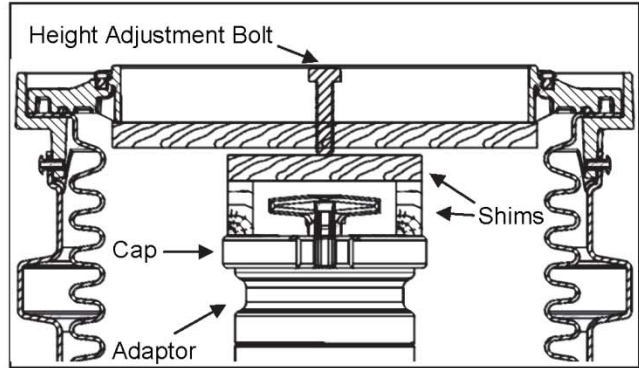


Figure 4

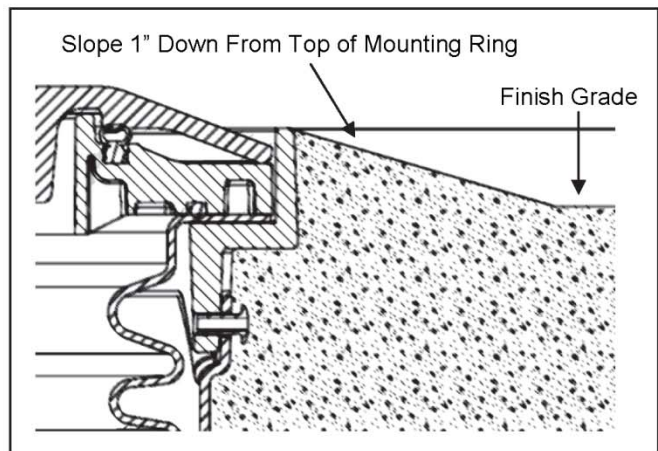


Figure 5

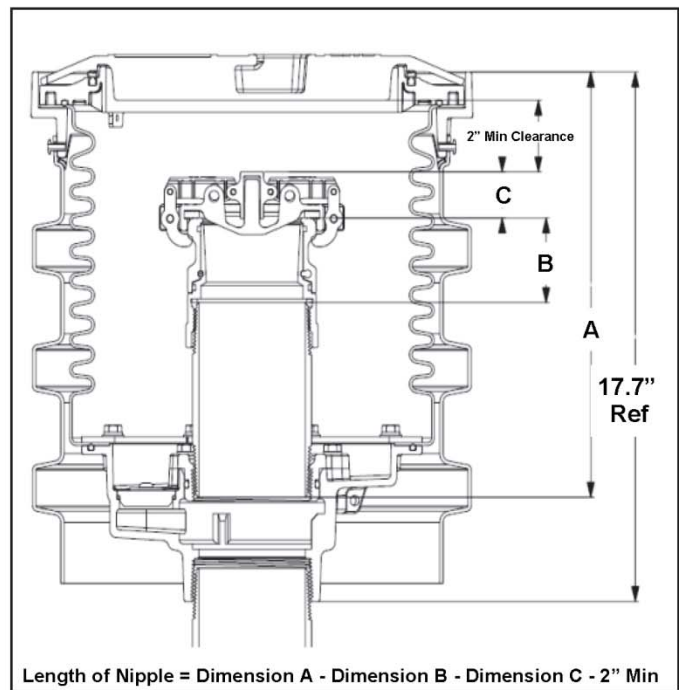


Figure 6

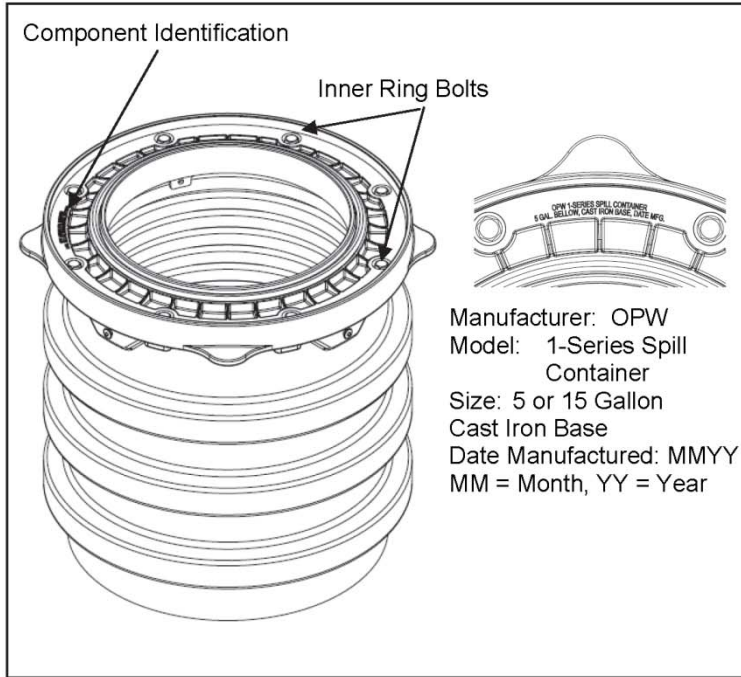


Figure 7

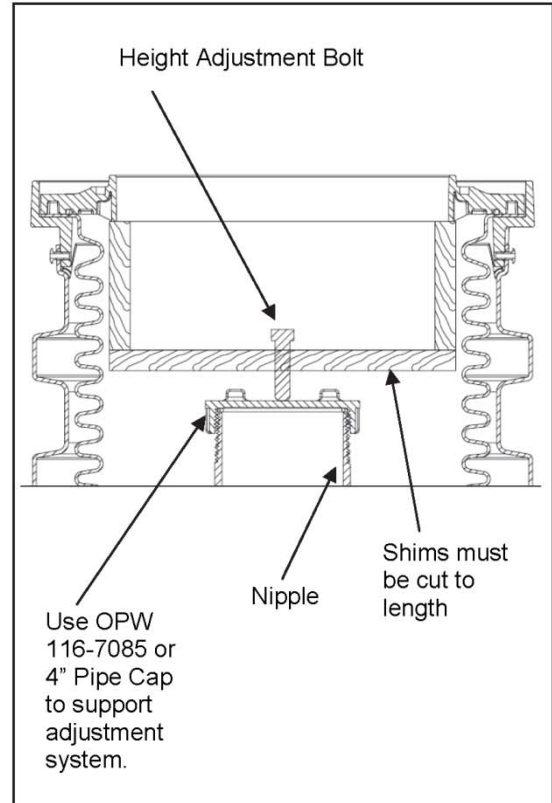


Figure 8



**OPW Retail Fueling**  
 3250 US 70 Business West  
 Smithfield, NC 27577  
 Customer Service: 1-(800) 422-2525  
 Technical Service and Questions:  
 1-(877) OPW-TECH  
 www.opwglobal.com

**Part Number:** 208197  
**Issue Date:** DRAFT 04-24-2014  
**Supersedes:** xxxxxx

Notice: OPW products must be used in compliance with applicable federal, state, provincial and local laws and regulations. Product selection should be based on physical specifications and limitations and compatibility with the environment and material to be handled. OPW makes no warranty of fitness for a particular use. All illustrations and specifications in this literature are based on the latest production information available at the time of publication. Prices, materials and specifications are subject to change at any time, and models may be discontinued at any time, in either case, without notice or obligation. For complete OPW warranty information, visit our web site at www.opwglobal.com.



## OPW 1-3100 Series Thread-On Double Wall Grade Level Spill Containers Installation and Maintenance Instructions

**IMPORTANT:** Please read these warnings and assembly instructions completely and carefully before starting. Failure to do so may cause product failure, or result in environmental contamination due to liquid leakage into the soil, creating hazardous spill conditions.

**IMPORTANT:** The OPW 1-3100 Spill Container is preassembled for your convenience and ease of installation. Check to make sure the unit is intact and undamaged and all parts have been supplied. Never substitute parts for those supplied. Doing so may cause product failure.

**WARNING-DANGER:** Using electrically operated equipment near gasoline or gasoline vapors may result in a fire or explosion, causing personal injury and property damage. Be sure that the working area is free from such hazards, and always use proper precautions.

**NOTE:** Keep the riser pipe capped at all times when product is in the storage tank, so the vapors cannot escape into the environment.

Notice: FlexWorks by OPW, Inc., VAPORSAVER™ and all other OPW products must be used in compliance with all applicable federal, state, provincial and local laws, rules and regulations. Product selection is the sole responsibility of the customer and/or its agents and must be based on physical specifications and limitations, compatibility with the environment and material to be handled. All illustrations and specifications in this literature are based on the latest production information available at the time of publication. Prices, materials and specifications are subject to change at any time, and models may be discontinued at any time, in either case, without notice or obligation.

This section intentionally left blank.

**Date of manufacture on this product is located on the mounting ring of the bucket.**

In some states it is prohibited to use spill container drain valves on spill containers that are exclusively used for vapor return risers. Install only 1-3100 Series Thread-On spill container models equipped with a drain plug.

**WARNING:** If the snowplow ring is removed, for any reason, follow the Operation and Maintenance instruction as noted. Replace o-rings and seals and install new ones. Never reuse damaged o-rings or seals as it may result in an improper seal. Only qualified, competent, well-trained technicians should perform maintenance. Common sense and good judgment should always be exercised. The contractor's understanding of all related site conditions prior to starting the project is essential. If the contractor does not have a clear understanding of the required work and site conditions, the contractor is advised to seek clarification prior to starting any portion of the project.

**NOTICE TO DELIVERY DRIVER:** All delivery drivers MUST

inspect the inside of the container for water or contaminants other than fuel prior to delivery. If water or contaminants are present, then they MUST be removed before proceeding. Dispose of towels and debris safely and per all applicable local, state, and federal codes. After delivery is complete, the driver MUST drain any excess fuel that may have spilled into the container from their delivery hose.

**1-3100 Series Performance Specifications:** This Spill Container drain valve has been manufactured and tested to the following specifications: Leak Rate to be less than or equal to 0.17 CFH @ 2.0" W.C.

**Torque Specification:**

Spill Container 4" NPT, 125 ft-lbs minimum to 250 ft-lbs maximum.

4" Nipple: 4" NPT, 125 ft-lbs minimum to 250 ft-lbs maximum.

**NOTE: All 4" NPT threads are to be torqued progressively lower from the tank up.**

Drain Valve clamps: 5/16-18 UN thread, 11.5 ft-lbs minimum to 13.5 ft-lbs maximum.

Ring and Nipple Adaptor Bolts: 3/8-16 UN, 20 ft-lbs minimum to 25 ft-lbs maximum.

**Tools Recommended:**

1-3100-TOOL - Torque Installation Tool

DW-VAC-TEST - Vacuum Test Equipment (or 202310 Test Adaptor)

**OPW 1-3100 SERIES GRADE LEVEL SPILL CONTAINER INSTALLATION INSTRUCTIONS:**

**Step 1:** (See Figures 1 and 2)

Determine riser pipe height. "L" is the distance between the top of the riser pipe and finish grade.

**NOTE: The spill container height (from riser to grade) is L + 1".**

**Model Series**

**"L" Dimension**

1-3100, 5 Gal. (Cast Iron Base)

L = 15 5/8" (40 cm)

1-3100, 15 Gal. (Cast Iron Base)

L = 17 3/8" (44 cm)

**Step 2:**

De-burr and thoroughly clean riser pipe. Apply pipe dope to riser threads. Pipe dope is to be a non-hardening, gasoline resistant pipe thread seal compound.

**Step 3:**

Install gravel guard on riser pipe. Leave band clamp loose.

**NOTE: Ground riser pipe to nearest grounding rod.**

**Step 4:**

Install spill container by rotating the mounting ring until hand tight.

This section intentionally left blank.

**NOTE: Do NOT attempt to completely tighten the container using the mounting ring. Doing so may cause the unit to fail.**

**Step 5: (See Figure 2)**

Finish tightening the spill container secondary base using the wrenching boss or with the 1-3100-TOOL. Torque to 125 ft-lbs min. to 250 ft-lbs max (4" NPT). 1-3100-TOOL can be used to set final torque (see 1-3100-TOOL instructions). **NOTE:** Per PEI RP100 Section 5.11, support the spill container after installing before backfilling.

**Step 6: (See Figures 2 & 3)**

Remove Nipple Adaptor from spill container. Apply pipe dope to nipple and install in Nipple Adaptor. Pipe dope is to be a non-hardening, gasoline resistant pipe thread seal compound. Use only factory made nipples. Torque nipple to 125 ft-lbs min. to 250 ft-lbs max. (4" NPT). 1-3100-TOOL can be used to set final torque. Torque value is based on rotation at the center of pipe. For standard covers install rotatable adaptor and dust cap per manufacturers' instructions. For sealable cover (1SC) models, install a standard 4" pipe cap to support adjustment system. (Adaptor and dust cap must be installed in sealable cover (SC) models after concrete has dried. Install drop tube, overfill prevention valve and/or loose jack screw assembly if used (61JSK-44CB) per manufacturers' instructions. Reinstall the Nipple Adaptor in spill container. Torque Nipple Adaptor bolts to 20 ft-lbs minimum to 25 ft-lbs maximum.

**NOTE: Nipple length is determined by measuring from the bottom of the threaded portion of the base to the bottom of the cover. Then subtract 2" minimum for clearance, height of adaptor and height of cap. Range of nipple lengths that can be used in all of the OPW spill containers: 4" min to 9" max. (See Figure 6)**

**Step 7: (See Figures 4 & 8)**

If necessary, the height of the spill container can be adjusted by ±1" (2.5cm). If it is necessary to increase height, install adjusting system (sold separately for 5 gallon models, part number H12267) beneath tabs on mounting ring. See Figure 4 for standard cover models and Figure 8 for sealable cover models. Add shims as needed and adjust with screw (shims must be cut to size for sealable cover models).

**NOTE: The adjustment should not be more than 1" from the initial length of the unit.**

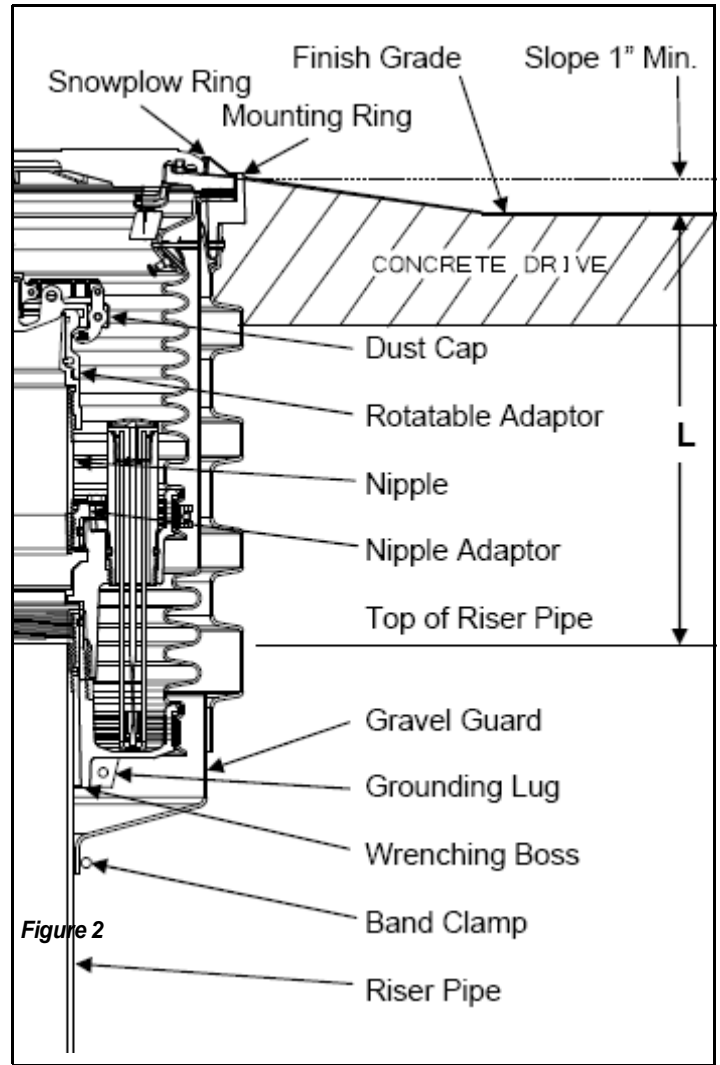


Figure 2

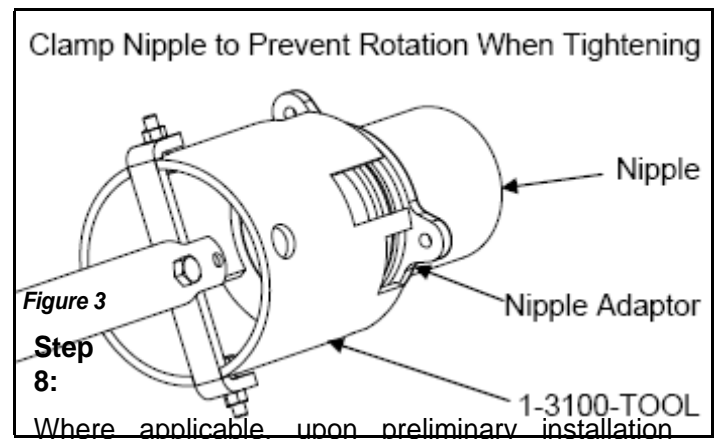


Figure 3

**Step 8:** Where applicable, upon preliminary installation

perform the CARB Test Procedure TP-201.1C or equivalent. This Test Procedure will check the seals between the drain valve, nipple, bases, and rotatable adaptor.

**NOTE: Follow all state and local required testing on the primary and secondary buckets.**

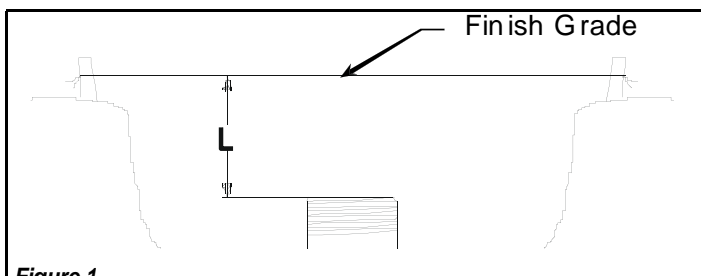


Figure 1

**Step 9: (See Figure 7)**

Verify torque on mounting ring bolts. Torque to be 20 ft-lbs minimum to 25 ft-lbs maximum. Using OPW DW-VAC-TEST (or 202310 Test Adaptor), perform a vacuum test on the spill container. An initial vacuum of 15" of water should be attained and the spill container must retain a vacuum of at least 12" of water after 5 minutes. (See DW-VAC-TEST Instructions.)

**Step 10: (See Figure 2)**

Install gravel guard at final height as shown in Figure 2 and tighten band clamp to 30 in-lbs. Where applicable, per California SB-989, all metal must be protected from direct contact with the elements. Coat stainless steel band clamp with the following approved coatings: OPW SL-1100, 3M Underseal 08883 or Polyguard Mastic CA-9.

**Step 11: (See Figures 2 & 5)**

Before pouring concrete, place plastic over the cover and Mounting Ring protecting them from concrete splash and tighten the clamp on the gravel guard mounted on the riser pipe. Double check that the unit is level and at proper grade height. Pour concrete per Figure 5. Ramp or dome the concrete away from the mounting ring.

There should be a minimum of 1" slope to finish grade.

**NOTE: Do not stand on spill container before concrete sets up.**

Remove plastic from cover after concrete has dried. Remove adjustment system. Re-test the spill containers for leaks as described in step 9, after the concrete has set up.

**Operation and Maintenance:**

After each fuel delivery, the operator must remove any standing fuel from the container. Fuel can be removed by actuating the drain valve or with a gasoline absorbing disposable towel. If access to drop tube or overfill valve is required remove Nipple Adaptor from primary bucket.

**Weekly:** Perform a visual inspection of the interior of the primary containment bucket for water or other contaminants and check the secondary containment bucket by checking the gauge in the base of the spill container. If water or other contaminants are found they must be disposed of with disposable towels. Dispose of towels safely and per all applicable local, state and federal codes. Check that cover is in good condition and properly identified. Replace cover and seal as necessary. Inspect the bucket walls for cracks, bulges or holes. If any exist, have that spill container barricaded and contact maintenance personnel immediately for repairs.

**Semiannually:** Follow all state and local required hydrostatic or vacuum testing on the primary and secondary buckets. Inspect and clean the interior of the spill container and drain valve screen. Remove accumulated dirt and grit. Where applicable, test the drain valve using CARB procedure TP-201.1C or TP-201.1D. If the drain valve passes testing no further maintenances required. If the drain valve fails testing, remove the valve, soak in water and use high-pressure air, if needed, to clean. Reinstall the drain valve to its proper position and

where applicable, test the valve with CARB procedure TP- 201.1C or TP-201.1D. If problems persist, replace the drain valve with P/N 1DK-2100-EVR (specified torque 11.5 ft-lbs min to 13.5 ft-lbs max, 5/16-18 UN thread). The sealable cover (1SC) adjustment nut is set at the factory, but due to environmental conditions it may be necessary to adjust it to either improve sealing or ease cover removal.

**IMPORTANT: Leave these instructions with the Station Operator.**

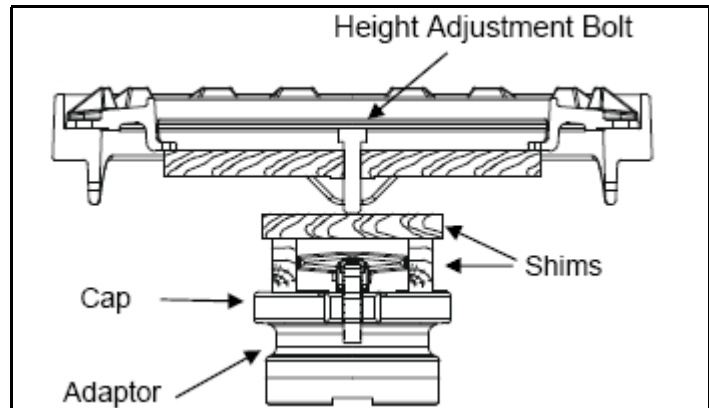


Figure 4

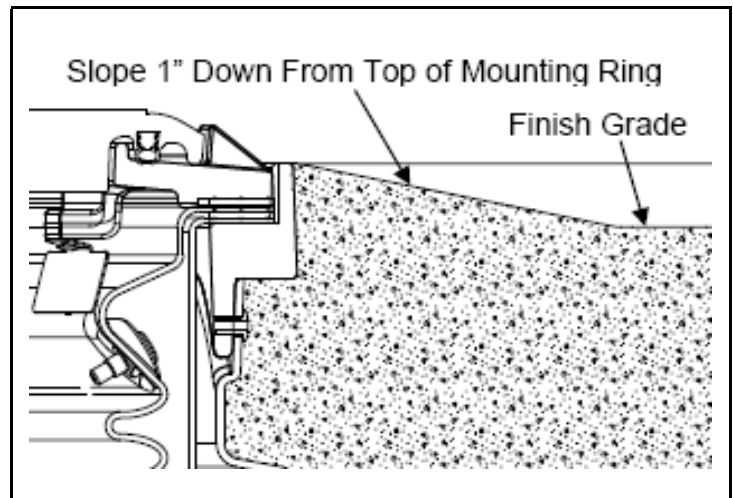


Figure 5

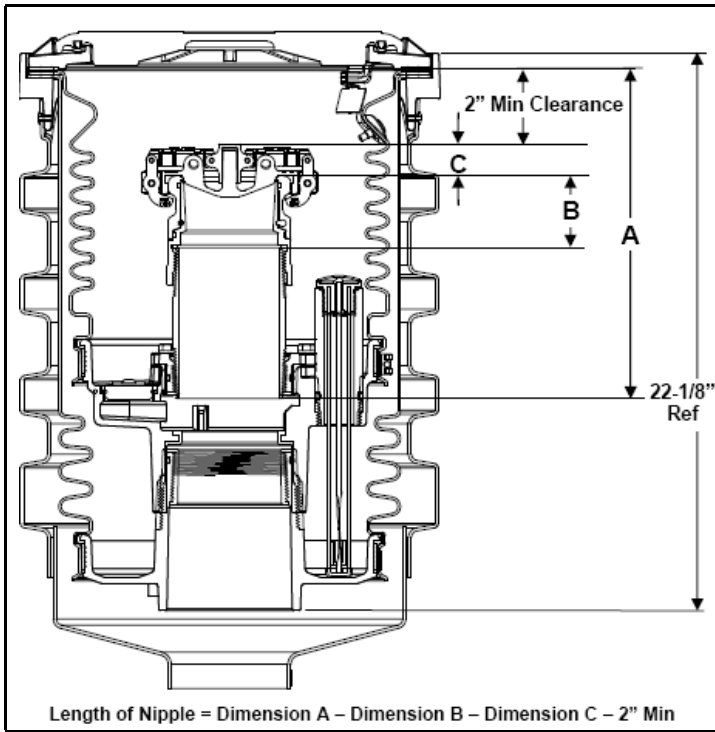


Figure 6

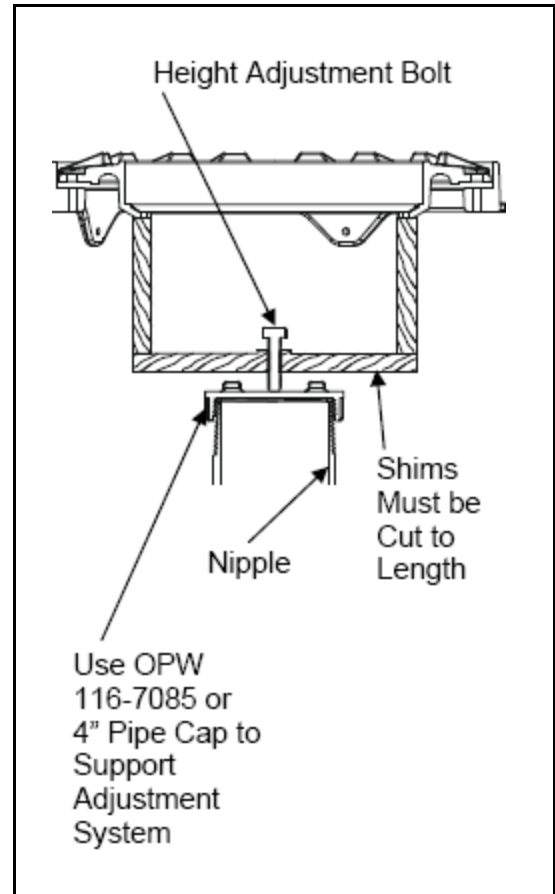


Figure 8

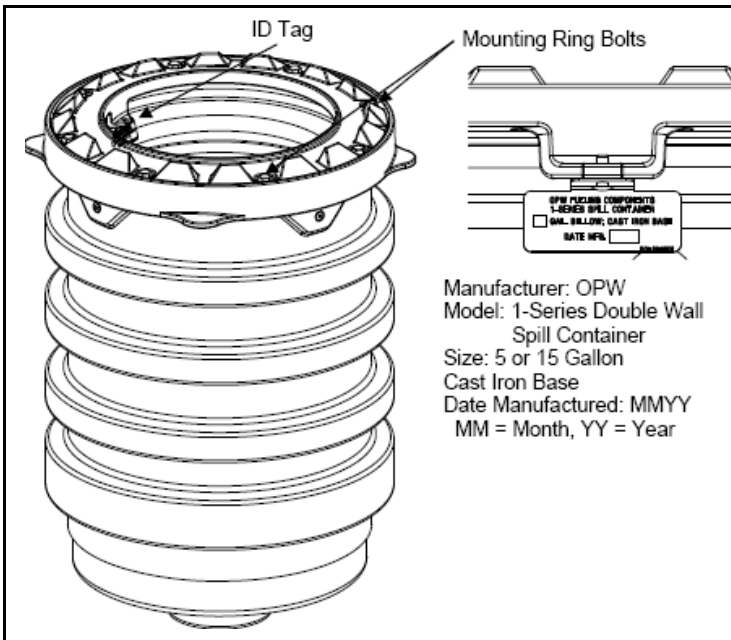


Figure 7



**OPW Fueling Containment Systems**  
 3250 US 70 Business West  
 Smithfield, NC 27577  
 Customer Service: 1-(800) 422-2525  
 Technical Service and Questions:  
 1-(877) OPW-TECH  
 www.opwglobal.com







## Installation and Maintenance Instructions OPW 1DK-2100 EVR Replacement Drain Valve

**IMPORTANT:** Please read these warnings and assembly instructions completely and carefully before starting. Failure to do so may cause product failure, or result in environmental contamination due to liquid leakage into the soil, creating hazardous spill conditions.

**IMPORTANT:** Check to make sure the unit is intact and undamaged and all parts have been supplied. Never substitute parts for those supplied. Doing so may cause product failure and void warranty.

**WARNING-DANGER:** Using electrically operated equipment near gasoline or gasoline vapors may result in a fire or explosion, causing personal injury and property damage. Be sure that the working area is free from such hazards, and always use proper precautions.

**NOTE:** At all times when product is in the storage tank keep the riser pipe capped, so the vapors cannot escape into the environment.

This section intentionally left blank.

Notice: FlexWorks by OPW, Inc., VAPORSAVER™ and all other OPW products must be used in compliance with all applicable federal, state, provincial and local laws, rules and regulations. Product selection is the sole responsibility of the customer and/or its agents and must be based on physical specifications and limitations, compatibility with the environment and material to be handled. All illustrations and specifications in this literature are based on the latest production information available at the time of publication. Prices, materials and specifications are subject to change at any time, and models may be discontinued at any time, in either case, without notice or obligation.

**HOW TO INSTALL**

The OPW 1DK is an optional drain valve replacement kit for the OPW 1 Spill Container Series. It is designed to return incidental spillage of liquid back to the underground storage tank.

1. Remove and discard existing drain valve and O-ring.
2. Clean any dirt or debris from the sealing surface where the new drain valve will be installed.
3. Apply any common grease or light oil to the new supplied O-ring. Assemble the O-ring into the spill container base.
4. Insert the 1DK into the spill container O-ring. Be sure that the drain valve seats flush with the floor of the spill container base.
5. The pull lever of the 1DK MUST be positioned half-way between the riser pipe nipple and the spill container bellows. Rotate the drain valve until that position is attained.
6. Secure the 1DK by installing the provided retaining clips and nuts. Tighten the nuts to a torque of 11.5 ft-lbs min. to 13.5 ft-lbs max.
7. The drain valve is now installed and ready for testing.

This section intentionally left blank.

**HOW TO TEST (UST):**

Upon preliminary installation perform the California Test Procedures TP-201.1C or equivalent. Their Test Procedures will check the seals between the drain valve, nipple and rotatable adapter. To test the spill containers base and bellows fill the container with water. A drop in the water level of 1/16" or more after one hour means that a leak exists. To determine where the leak is, look for a steady stream of bubbles coming from one of the joints. **NOTE:** Do not drain the water into the UST after the test is complete. Water must be disposed of per local requirements for hazardous waste.

If a leak is observed in the Test Procedure, check to see that the drain valve poppet is sealing properly. To do this, lift up the drain valve pull chain several times to actuate the poppet. This will ensure that the drain valve poppet is seating properly. If this doesn't correct the leak remove the 1DK valve and inspect the O-ring for nicks or tears, replace if needed, also clean the sealing surfaces of the spill container base that the 1DK valve and O-ring are installed into. Reinstall 1DK valve and repeat test.

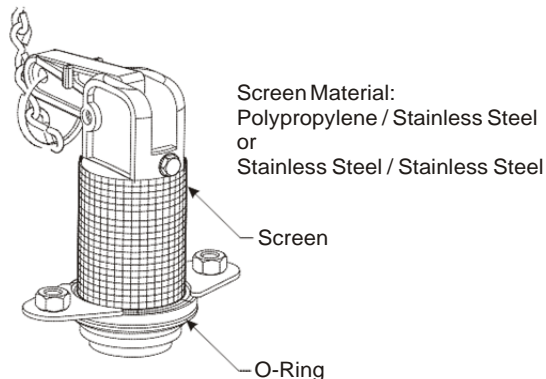
If spill container passes the Test Procedure but does not hold water then there is a leak in the bucket and will need to be replaced.

**HOW TO TEST (AST):**

Upon preliminary installation perform the California Test Procedures TP-206.3 or equivalent. Test the drain valve by applying a soap solution to the drain valve

while the aboveground storage tank is under a positive gauge pressure of at least 2.00 inches W.C (per TP206.3) and inspect for the presence of bubbles. A bag test may be used by sealing a clear plastic bag around the drain valve. If no bubbles appear at the drain valve under positive pressure or the bag test shows no signs of the bag infalting, no further maintenance is required. If bubbles appeared around the drain valve or the bag inflated, replace the drain valve and re-test.

**Alternative Construction**



**1DK-2100 EVR Replacement Drain Valve Performance Specifications:**

This section intentionally left blank.

This Spill Container drain valve has been manufactured and tested to the following California specifications: Leak Rate to be less than or equal to 0.17 CFH @ 2.0" W.C.

**Operation and Maintenance**

To open, pull drain valve chain up and hold open until liquid is drained. To close, release chain.

**Annually:** Inspect and clean the interior of the spill container and drain valve screen. Remove accumulated dirt and grit. Test the drain valve using CARB procedure TP-201.1C or TP-201.1D. If the drain valve passes testing no further maintenances required. If the drain valve fails testing, remove the valve, soak in water and use high-pressure air, if needed, to clean. Reinstall the drain valve to its proper position and test the valve with CARB procedure TP-201.1C or TP-201.1D.

**IMPORTANT: Leave these Instructions with the Station Operator.**



3250 US 70 Business West  
Smithfield, NC 27577  
Customer Service: 1-(800) 422-2525  
Technical Service and Questions:  
1-(877) OPW-TECH  
www.opwglobal.com



## Installation and Maintenance Instructions OPW 1DP-2100 EVR Replacement Drain Plug

**IMPORTANT:** Please read these warnings and assembly instructions completely and carefully before starting. Failure to do so may cause product failure, or result in environmental contamination due to liquid leakage into the soil, creating hazardous spill conditions.

**IMPORTANT:** Check to make sure the unit is intact and undamaged and all parts have been supplied. Never substitute parts for those supplied. Doing so may cause product failure.

**WARNING-DANGER:** Using electrically operated equipment near gasoline or gasoline vapors may result in a fire or explosion, causing personal injury and property damage. Be sure that the working area is free from such hazards, and always use proper precautions.

**NOTE:** At all times when product is in the storage tank keep the riser pipe capped, so the vapors cannot escape into the environment.

**Notice:** OPW products must be used in compliance with applicable federal, state, and local laws and regulations. Product selection should be based on physical specifications and limitations and compatibility with the environment and material to be handled. OPW makes no warranty of fitness for a particular use. All illustrations and specifications in this literature are based on the latest production information available at the time of publication. Prices, materials, and specification are subject to change at any time, and models may be discontinued at any time, in either case, without notice or obligation.

**OPW Standard Product Warranty Tag:** Notice: FlexWorks by OPW, Inc., VAPORSAVER™ and all other OPW products must be used in compliance with all applicable federal, state, provincial and local laws, rules and regulations. Product selection is the sole responsibility of the customer and/or its agents and must be based on physical specifications and limitations, compatibility with the environment and material to be handled. All illustrations and specifications in this literature are based on the latest production information available at the time of publication. Prices, materials and specifications are subject to change at any time, and models may be discontinued at any time, in either case, without notice or obligation.

OPW warrants solely to its customer (the initial purchaser and any subsequent purchasers within the warranty period) that the following products sold by OPW will be free from defects in materials and workmanship under normal use and conditions for the periods indicated:

chaser and any subsequent purchasers within the warranty period) that the following products sold by OPW will be free from defects in materials and workmanship under normal use and conditions for the periods indicated:

PRODUCT	WARRANTY PERIOD
FlexWorks Primary Pipe	10 years from date of manufacture
All Products and replacement parts installed in the State of California Certified to California CP-201 and/or CP-206 Standards*	1 year from date of installation (proof of purchase from certified contractors/technicians required) OPW warrants ongoing compliance with the standards and specifications for the duration of the warranty period required by the State of California; this limited warranty is under the condition the equipment was installed and maintained by trained and certified contractors/technicians unless noted in Installation Manual.
All other Products and replacement parts	1 year from date of manufacture**
*Products certified to California CP-201 and/or CP-206 Standards have been factory tested and met all applicable performance standards and specifications and will have an OPW registration card enclosed/attached to the product.	

OPW's exclusive obligation under this limited warranty is, at its option, to repair, replace or issue credit (in an amount not to exceed the list price for the product) for future orders for any product that may prove defective within the applicable warranty period. (Parts repaired or replaced under warranty are subject to prorated warranty coverage for remainder of the original warranty period). Complete and proper warranty claim documentation and proof of purchase required. All warranty claims must be made in writing and delivered during the applicable warranty period to OPW at OPW 9393 Princeton-Glendale Road Hamilton, Ohio, USA 45011, Attention: Customer Service Manager. No products may be returned to OPW without its prior written authority.

This limited warranty shall not apply to any FlexWorks or VAPORSAVER™ product unless it is installed by an OPW attested installer and all required site and warranty registration forms are completed and received by OPW within 60 days of installation. This limited warranty also shall not apply to any FlexWorks, VAPORSAVER™

or other OPW product: unless all piping connections are installed with a nationally-recognized or state-approved leak detection device in each tank and dispenser sump (which are not for storage and from which all discharge hydrocarbons must be removed, and the systems completely cleaned, within 24 hours); unless testable sumps utilize FlexWorks pipe and access fittings; unless a sump inspection log or an EPA recommended/required checklist is maintained and the results are furnished to OPW upon request; and unless OPW is notified within 24 hours of any known or suspected product failure and is provided with unrestricted access to the product and the site. This limited warranty also shall not apply to any product which has been altered in any way, which has been repaired by anyone other than a service representative authorized by OPW, or when failure or defect is due to: improper installation or maintenance (including, without limitation, failure to follow FlexWorks Quick Reference Manual Installation Guide and all product warning labels); abuse or misuse; violation of health or safety requirements; use of another manufacturer's, or otherwise unauthorized, substances or components; soil or other surface or subsurface conditions; or fire, flood, storm, lightning, earthquake, accident or any other conditions, events or circumstances beyond OPW's control .

THIS LIMITED WARRANTY IS IN LIEU OF ALL OTHER WARRANTIES, EXPRESS OR IMPLIED, AND ALL OTHER WARRANTIES INCLUDING, WITHOUT LIMITATION, THE WARRANTIES OF MERCHANTABILITY AND FITNESS FOR A PARTICULAR PURPOSE, ARE HEREBY EXCLUDED.

OPW shall have no other liability whatsoever, whether based on breach of contract, negligence, gross negligence, strict liability or any other claim, including, without limitation, for special, incidental, consequential or exemplary damages or for the cost of labor, freight, excavation, clean-up, downtime, removal, reinstallation, loss of profit, or any other cost or charges. No person or entity is authorized to assume on behalf of OPW any liability beyond this limited warranty. This limited warranty is not assignable.

The OPW 1DP is an optional drain plug replacement kit for the OPW 1 Series Spill Container. It is designed to plug the drain valve for the OPW 1 Series Spill Container.

### HOW TO INSTALL

1. Remove and discard existing drain valve and O-ring.
2. Clean any dirt or debris from the sealing surface where the new drain valve will be installed.
3. Apply any common grease or light oil to the new supplied O-ring. Assemble the O-ring into the spill

container base.

4. Insert the 1DP Plug into the spill container O-ring. Be sure that the Plug seats flush with the floor of the spill container base.
5. Secure the 1DP by installing the provided retaining washer and nuts or bolts. Composite base spill containers use nuts to secure the drain plug (see Figure 1) and cast iron base models use bolts (see Figure 2). Tighten the nuts / bolts to a torque of 11.5 ft-lbs min. to 13.5 ft-lbs max .
6. The Drain Plug is now installed and ready for testing.

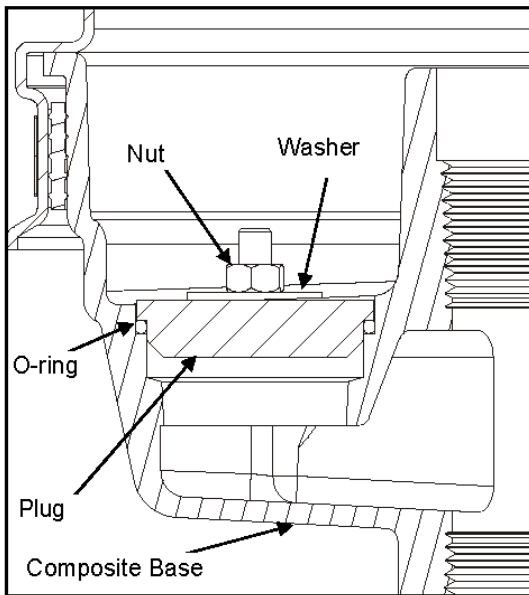
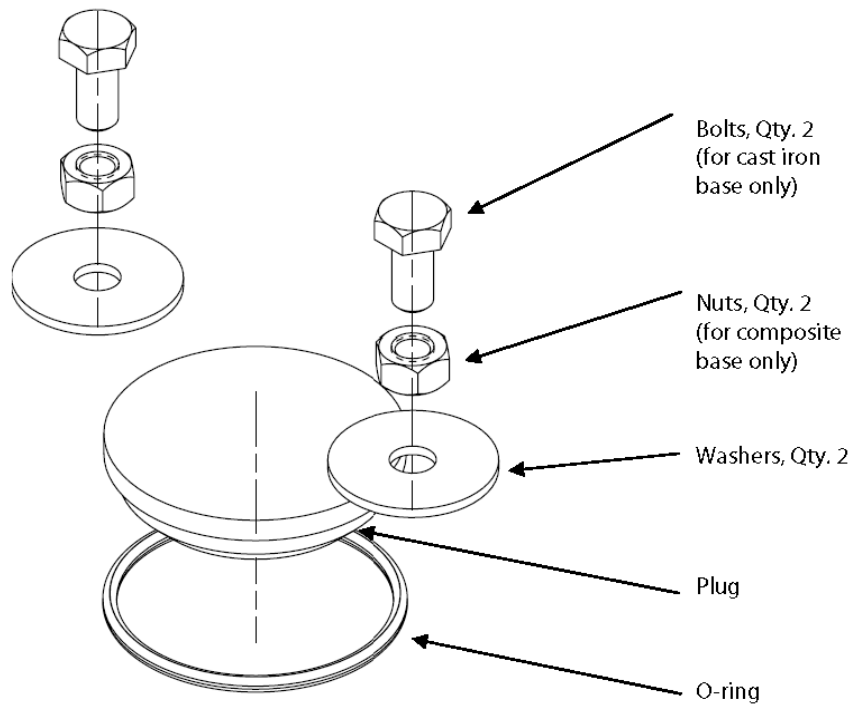
### HOW TO TEST:

To test the spill containers base and bellows fill the container with water. A drop in the water level of 1/16" or more after one hour means that a leak exists. To determine where the leak is, look for a steady stream of bubbles coming from one of the joints. **NOTE:** Do not drain the water into the UST after the test is complete. Water must be disposed of per local requirements for hazardous waste.

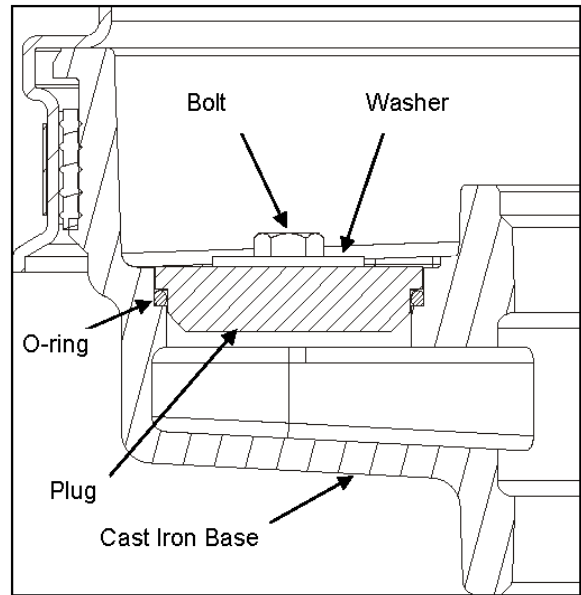
If a leak is observed in the Test Procedure, check to see that the drain plug is sealing properly. To do this, remove nut, washer and plug and inspect the O-ring for nicks or tears, replace if needed, also clean the sealing surfaces of the spill container base that the 1DP drain plug and O-ring are installed into. Reinstall 1DP valve and repeat test.

If spill container passes the Test Procedure but does not hold water then there is a leak in the bucket and will need to be replaced.

### 1DP Parts Diagram



**Figure 1 - Composite Base with Plug**





**Figure 2 - Cast Iron Base with Plug**



3250 US 70 Business West  
Smithfield, NC 27577  
Customer Service: 1-(800) 422-2525  
Technical Service and Questions:  
1-(877) OPW-TECH  
[www.opwglobal.com](http://www.opwglobal.com)

Part Number:	H15199M
Issue Date:	04/28/2013
	Rev C

**OPW**  **Installation and Maintenance Instructions**  
**OPW634TT-EVR and 1711T-EVR Dust Caps**  
FUELING CONTAINMENT SYSTEMS  
A  COMPANY

**IMPORTANT:** Please read these warnings and assembly instructions completely and carefully before starting. Failure to do so may cause product failure, or result in environmental contamination due to liquid leakage into the soil, creating hazardous spill conditions.

**IMPORTANT:** Check to make sure the product is intact and undamaged and all parts have been supplied. Never substitute parts for those supplied. Doing so may cause product failure.

**WARNING-DANGER:** Using electrically operated equipment near gasoline or gasoline vapors may result in a fire or explosion, causing personal injury and property damage. Be sure that the working area is free from such hazards, and always use proper precautions.

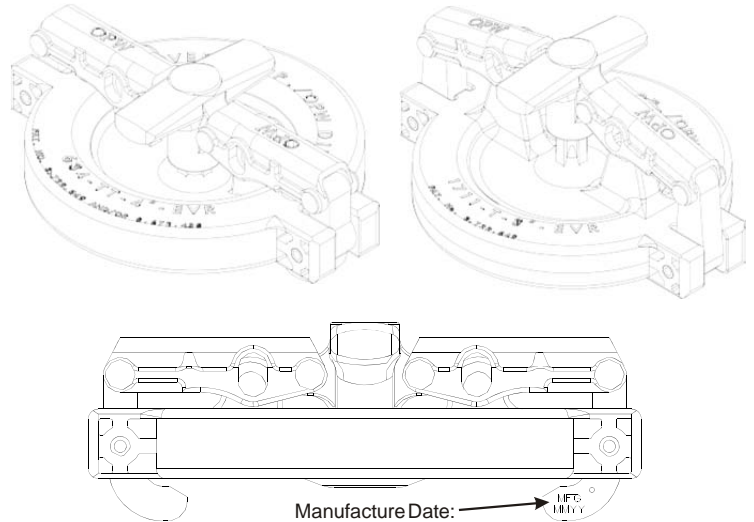
**Notice:** OPW products must be used in compliance with applicable federal, state, and local laws and regulations. Product selection should be based on physical specifications and limitations and compatibility with the environment and material to be handled. All illustrations and specifications in this literature are based on the latest production information available at the time of publication. Prices, materials, and specification are subject to change at any time, and models may be discontinued at any time, in either case, without notice or obligation.

This section intentionally left blank.

Notice: FlexWorks by OPW, Inc., VAPORSAVER™ and all other OPW products must be used in compliance with all applicable federal, state, provincial and local laws, rules and regulations. Product selection is the sole responsibility of the customer and/or its agents and must be based on physical specifications and limitations, compatibility with the environment and material to be handled. All illustrations and specifications in this literature are based on the latest production information available at the time of publication. Prices, materials and specifications are subject to change at any time, and models may be discontinued at any time, in either case, without notice or obligation.



Date of manufacture on this product is stamped on the metal cam.



This section intentionally left blank.

**PRODUCT IDENTIFICATION:**

Manufacture: "DOVER CORP / OPW DIV."  
Model: "634-TT-4-EVR" or "1711-T-3-EVR"  
Date Manufactured: "MFG MM/YY"  
MM=Month, YY=Year

**OPERATION AND MAINTENANCE:**

1. Annually inspect seal for nicks, tears or deformations. If required, replace with OPW P/N H15005M for 634TT and H10886M for 1711T.



3250 US 70 Business West  
Smithfield, NC 27577  
Customer Service: 1-(800) 422-2525  
Technical Service and Questions:  
1-(877) OPW-TECH  
www.opwglobal.com



## Installation and Maintenance Instructions OPW 634LPC and 1711LPC Dust Caps

**IMPORTANT:** Please read these warnings and assembly instructions completely and carefully before starting. Failure to do so may cause product failure, or result in environmental contamination due to liquid leakage into the soil, creating hazardous spill conditions.

**IMPORTANT:** Check to make sure the product is intact and undamaged and all parts have been supplied. Never substitute parts for those supplied. Doing so may cause product failure.

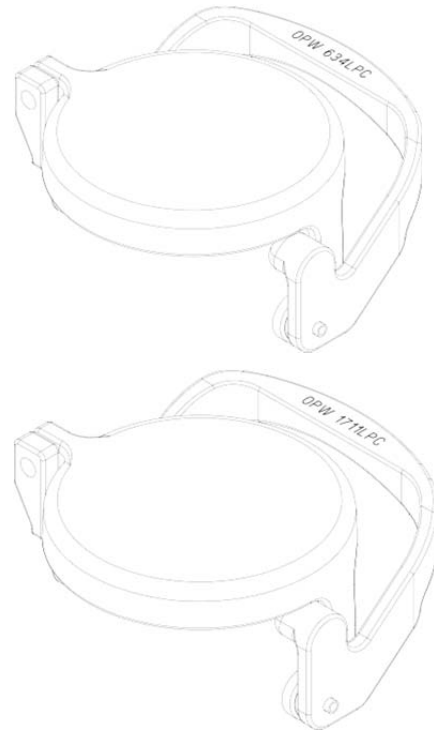
**WARNING-DANGER:** Using electrically operated equipment near gasoline or gasoline vapors may result in a fire or explosion, causing personal injury and property damage. Be sure that the working area is free from such hazards, and always use proper precautions.

**Notice:** OPW products must be used in compliance with applicable federal, state, and local laws and regulations. Product selection should be based on physical specifications and limitations and compatibility with the environment and material to be handled. All illustrations and specifications in this literature are based on the latest production information available at the time of publication. Prices, materials, and specification are subject to change at any time, and models may be discontinued at any time, in either case, without notice or obligation.

Notice: Flex- Works by OPW, Inc., VAPORSAVER™ and all other OPW products must be used in compliance with all applicable federal, state, provincial and local laws, rules and regulations. Product selection is the sole responsibility of the customer and/or its agents and must be based on physical specifications and limitations, compatibility with the environment and material to be handled. All illustrations and specifications in this literature are based on the latest production information available at the time of publication. Prices, materials and specifications are subject to change at any time, and models may be discontinued at any time, in either case, without notice or obligation.

This section intentionally left blank.

**Date of manufacture on this product is located on the underside of the cap.**



This section intentionally left blank.

**PRODUCT IDENTIFICATION:**

Manufacture: "OPW"

Model: "6344LPC" or "1711LPC"

Date Manufactured (located on underside): "MFG  
MMYY"; MM=Month, YY=Year

**OPERATION AND MAINTENANCE:**

1. Annually inspect seal for nicks, tears or deformations. If required, replace with OPW P/N H15005M.



3250 US 70 Business West  
Smithfield, NC 27577  
Customer Service: 1-(800) 422-2525  
Technical Service and Questions:  
1-(877) OPW-TECH  
[www.opwglobal.com](http://www.opwglobal.com)

## CompX Security Products (CSP) CSP1-634LPC, CSP2-634LPC, CSP3-1711LPC and CSP4-1711LPC Tank Commander Dust Caps

### TANK Commander – Warranty

Seller warrants to the initial and subsequent purchasers, for a period of one year from date of installation, that the Products sold hereunder will, at the time of delivery: (a) comply with the ARB CP-201 standards and specifications for the duration of the warranty period for such Products in effect at the time of shipment or such other specifications as are expressly agreed upon by Seller and Buyer in writing; (b) be adequately contained, packaged, and labeled; and (c) conform to any promises and affirmations of fact made on the container and label. In the event that any such Products fail to conform to the foregoing warranty, Seller will, at its option, repair or replace such nonconforming Products, or credit Buyer for an amount not to exceed the original sales price of such Products. Shipping costs incurred in returning such nonconforming Products to Seller shall be borne by Seller, but Seller shall in no event be liable for any inspection, handling, or packaging costs incurred by Buyer in connection with such Products. Buyer's negligence, misuse, improper installation, or unauthorized repair or alteration, shall void this warranty.

The TANK Commander Warranty tag is located on the inside cover of the product.

.....

#### Tank Commander features:

**Tank Commander fits all certified Phase 1 Vapor Recovery Systems: Phil-Tite, OPW, EBW, CNI and EMCO Wheaton**

- ◆ Stainless steel construction
- ◆ Vapor recovery seal remains intact
- ◆ Low profile fill cap included
- ◆ Fits common bronze adapters
- ◆ 24/7 protection for diesel and gas

#### TuBAR Tank Commander

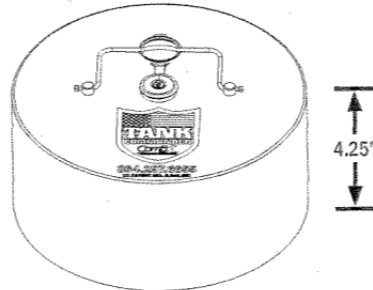
- ◆ TuBAR® lock for maximum key control
  - No key blanks available except from factory
  - Key series registered to your store(s)
- ◆ Keyed alike available – use the same key for both Tank Commander and dispenser

#### Padlock Tank Commander

- ◆ Available with heavy duty four number changeable combination padlock
- ◆ Or use existing padlock

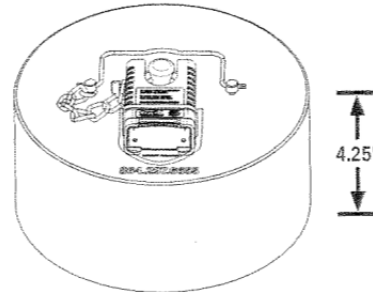
**TuBAR  
Tank  
Commander**

(P/N:  
TC-1,  
TC-1-V)



**Padlock  
Tank  
Commander**

(P/N:  
TC-PL,  
TC-PL-V)



ISO 9001 certified.

Copyright 2012 © CompX Security Products / 864.297.6655 / compx.com / PO Box 200, Mauldin, SC 29662  
Any companies and/or products referred to herein are marks or registered trademarks of their respective companies, owners and/or users.

## TANK Commander – Instructions

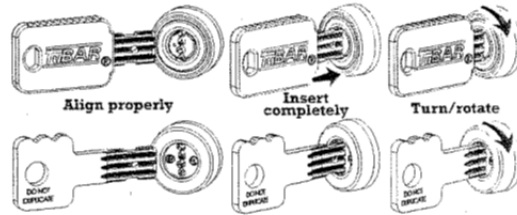
### Product Instructions

Remove existing dust cap OPW 634LPC, OPW 634TT-EVR, Morrison Brothers 305C-0100ACEVR, EBW 777-201-01, EBW 777-201-02, CNI Mfg. 64, OR EMCO Wheaton Retail A0097-005 and replace with appropriate TANK Commander dust cap; CSP1-634LPC, CSP2- 634LPC, CSP3- 1711LPC or CSP4-1711LPC. Make sure the handle lever is fully locked and the dust cap seal is engaged.

Annually inspect dust cap seal for nicks, tears or deformations and replace if necessary. Installation of TANK Commander should not violate any (height) limitations exhibited in California Air Resources Board Executive Orders VR101-VR105. If the original Vapor Recovery System installation will not allow correct installation of TANK Commander then modification to the vapor recovery system is required (i.e. fill pipe height reduction) to maintain installation requirements.

### TuBAR TANK Commander (P/N: TC-1, TC-1-V)

Insert key into the keyway of the lock on top of the stainless steel TANK Commander and rotate clockwise to retract locking bolt. Install stainless steel TANK Commander over the CSP1-634LPC product dust cap or CSP3-1711LPC vapor dust cap ensuring the lock body mounted in the sleeve fully engages the brass boss on top of the dust cap. Return the key to the 12 o'clock position and remove. The TANK Commander is now secured to the dust cap and should rotate freely.

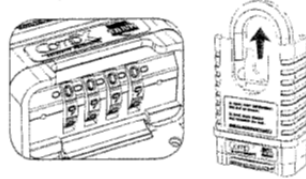


### Padlock TANK Commander (P/N: TC-PL, TC-PL-V)

Install stainless steel TANK Commander over dust cap spindle on CSP2-634LPC or CSP4-1711LPC; install padlock shackle through the spindle hole. Secure TANK Commander by locking the padlock; product should rotate freely.

The factory combination is 0-0-0-0. Be sure to record new combination. Warranty does not cover lost, stolen or incorrectly set combinations.

**To Open:** Spin the dials so the proper numbers align on top with the black hash marks. Pull the shackle up to unlock.

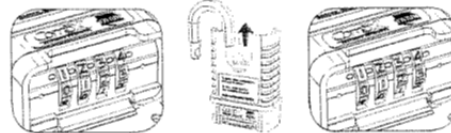


**To Close:** Push the shackle down to close. Scramble dials to lock the shackle. The dials will only spin when the shackle is in the locked position.

**To Change the Combination:** Open the lock using the proper combination and pull the shackle up to unlock. Turn the shackle 90° then press down completely. Now rotate another 90° to the left.



Set the dials to the new combination. Pull shackle up and check that the new combination remains set properly on the intended numbers.



See previous instructions (on left) to close and lock.



Standard Product Warranty on back.

ISO 9001 certified.

Copyright 2012 © CompX Security Products / 864.297.6655 / compx.com / PO Box 200, Mauldin, SC 29662  
 All trademarks and/or services are the property of their respective owners. © 2012 CompX, Inc.



## Installation and Maintenance Instructions OPW61SALPEVR (Low Profile) Rotatable Product Adaptors

Please read these warnings and assembly instructions completely and carefully before starting. Failure to do so may cause product failure, or result in environmental contamination due to liquid leakage into the soil, creating hazardous spill conditions.

**IMPORTANT:** Check to make sure the unit is intact and undamaged and all parts have been supplied. Never substitute parts for those supplied. Doing so may cause product failure.

**WARNING-DANGER:** Using electrically operated equipment near gasoline or gasoline vapors may result in a fire or explosion, causing personal injury and property damage. Be sure that the working area is free from such hazards, and always use proper precautions.

**NOTE:** At all times when product is in the storage tank keep the riser pipe capped, so the vapors cannot escape into the environment.

**Notice:** OPW products must be used in compliance with applicable federal, state, and local laws and regulations. Product selection should be based on physical specifications and limitations and compatibility with the environment and material to be handled. All illustrations and specifications in this literature are based on the latest production information available at the time of publication. Prices, materials, and specification are subject to change at any time, and models may be discontinued at any time, in either case, without notice or obligation.

This section intentionally left blank.

Notice: Flex- Works by OPW, Inc., VAPORSAVER™ and all other OPW products must be used in compliance with all applicable federal, state, provincial and local laws, rules and regulations. Product selection is the sole responsibility of the customer and/or its agents and must be based on physical specifications and limitations, compatibility with the environment and material to be handled. All illustrations and specifications in this literature are based on the latest production information available at the time of publication. Prices, materials and specifications are subject to change at any time, and models may be discontinued at any time, in either case, without notice or obligation.

**Date of manufacture on this product is located on the adaptor just below the groove.**

**61 SALP Performance Specifications:**

This Rotatable Adaptor has been manufactured and tested to the following California Specifications: Rotatable 360°, Static Torque maximum 108 inch-lbs.

**Preventative Maintenance**

**Annually** Inspect the adaptor for large dents, cracks or deformation. Replace if necessary. The rotation mechanism is not field serviceable.

**Replacement Parts**

Part Number	Description
H09039M	Nipple Sealing Gasket

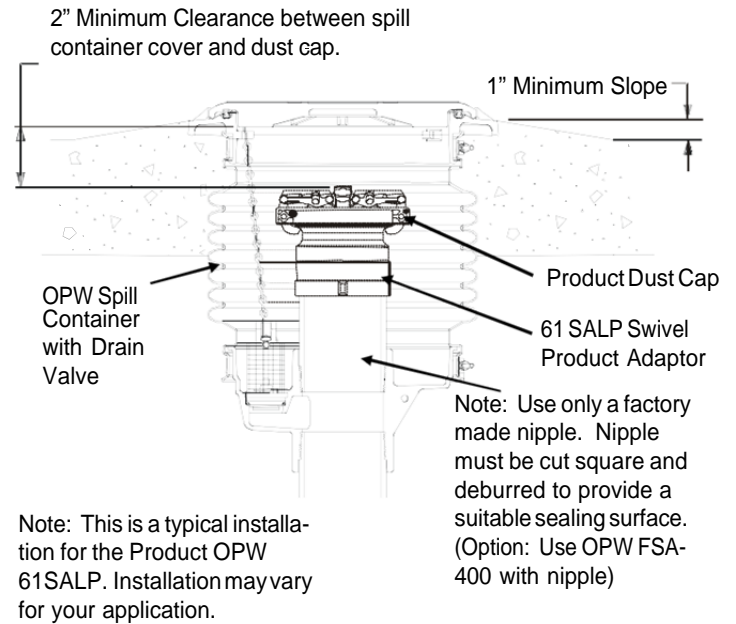
**Torque Specification**

Adaptor, 4" NPSM, 90 ft-lbs minimum to 110 ft-lbs maximum.

This section intentionally left blank.

**IMPORTANT: Leave these Installation Instructions with the Station Operator.**

**61 SALP EVR Rotatable Product Adaptor Installation Instructions**



**Step 1**

The riser nipple in the spill container must be cut square and deburred. See drawing note for the correct dis-

tance between the top of the nipple and finished grade. (Optional: Use an OPW FSA-400 Face Seal Adapter with nipple. Add 3-1/4" to distance from top of nipple to finish grade).

### Step 2 (Optional)

Apply pipe dope to the nipple. Pipe dope to be non-hardening, gasoline resistant pipe thread seal compound.

### Step 3

Tighten the Rotatable Adaptor onto the nipple with a torque of 90 ft-lbs min. to 110 ft-lbs max this will be enough torque to seat and seal the gasket. Use an OPW 61SA-TOOL to install rotatable adaptor.

### Static Torque Test

1) Using OPW 200459 Swivel Adaptor Torque Tool and OPW 634TT Product Cap, annually verify the static torque of the swivel adaptor by performing California ARB test procedure TP-201.1B.



Manufacture "OPW"  
Date Manufactured: "MFG MMY"  
MM= Month, YY=Year



Product ID: "61SALP"

This section intentionally left blank.



3250 US 70 Business West  
Smithfield, NC 27577  
Customer Service: 1-(800) 422-2525  
Technical Service and Questions:  
1-(877) OPW-TECH  
[www.opwglobal.com](http://www.opwglobal.com)





## Installation and Maintenance Instructions OPW 61VSA EVR Poppetted Rotatable Vapor Recovery Adaptors

Please read these warnings and assembly instructions completely and carefully before starting. Failure to do so may cause product failure, or result in environmental contamination due to liquid leakage into the soil, creating hazardous spill conditions.

**IMPORTANT:** Check to make sure the unit is intact and undamaged and all parts have been supplied. Never substitute parts for those supplied. Doing so may cause product failure.

**WARNING-DANGER:** Using electrically operated equipment near gasoline or gasoline vapors may result in a fire or explosion, causing personal injury and property damage. Be sure that the working area is free from such hazards, and always use proper precautions.

**NOTE:** At all times when product is in the storage tank keep the riser pipe capped, so the vapors cannot escape into the environment.

**Notice:** OPW products must be used in compliance with applicable federal, state, and local laws and regulations. Product selection should be based on physical specifications and limitations and compatibility with the environment and material to be handled. All illustrations and specifications in this literature are based on the latest production information available at the time of publication. Prices, materials, and specification are subject to change at any time, and models may be discontinued at any time, in either case, without notice or obligation.

This section intentionally left blank.

Notice: Flex- Works by OPW, Inc., VAPORSAVER™ and all other OPW products must be used in compliance with all applicable federal, state, provincial and local laws, rules and regulations. Product selection is the sole responsibility of the customer and/or its agents and must be based on physical specifications and limitations, compatibility with the environment and material to be handled. All illustrations and specifications in this literature are based on the latest production information available at the time of publication. Prices, materials and specifications are subject to change at any time, and models may be discontinued at any time, in either case, without notice or obligation.

**Date of manufacture on this product is located on the adaptor just below the groove.**

**61VSA Performance Specifications:**

This Rotatable Adaptor has been manufactured and tested to the following California Specifications: Rotatable 360°, Static Torque maximum 108 inch-lbs.

**Preventative Maintenance**

**Annually** Inspect the adaptor for large dents, cracks or deformation. Replace if necessary. The rotation mechanism is not field serviceable.

Check the vapor poppet for damage and ensure that the poppet seats evenly with the adaptor. Clean out any foreign objects from the vapor poppet's seal and seal surface if necessary. Test the poppet seal by applying a soap solution to the poppet while the under- ground or aboveground storage tank is under a positive gauge pressure of at least 2.00 inches W.C and inspect for the presence of bubbles. If the facility continuously operates under vacuum, a bag test may be used by sealing a clear plastic bag to the adaptor's sides.

If no bubbles appear at the poppet under positive pressure or the bag test shows no signs of the bag collapsing, no further maintenance is required. If bubbles appeared around the poppet seal or the bag collapsed, replace the poppet components and retest.

This section intentionally left blank.

**Replacement Parts**

Part Number	Description
H09039M	Nipple Sealing Gasket
61VSA-KIT	Vapor Poppet Kit

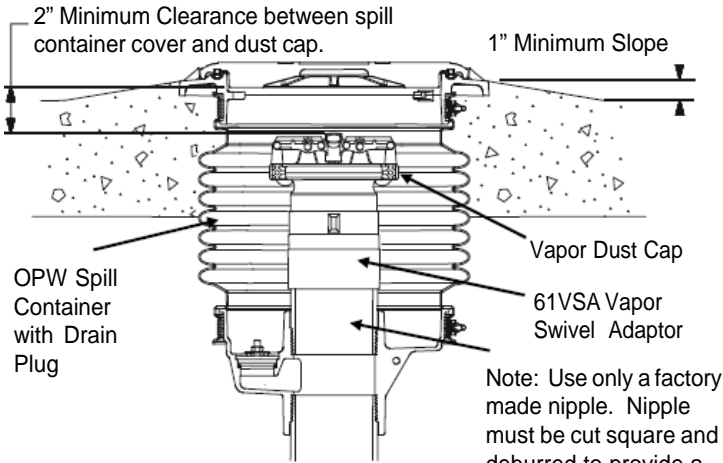
**Torque Specification**

Adaptor, 4" NPSM, 90 ft-lbs minimum to 110 ft-lbs maximum.

***Patent #5,664,951***

**IMPORTANT: Leave these Installation Instructions with the Station Operator.**

**61VSA EVR Series Poppeted Rotatable Vapor Adaptor  
Installation Instructions**



Note: This is a typical UST installation for the OPW 61VSA. Installation may vary for your application.

Note: Use only a factory made nipple. Nipple must be cut square and deburred to provide a suitable sealing surface. (Option: Use OPW FSA-400 with nipple).

**Step 1**

The riser nipple in the spill container must be cut square and deburred. See drawing note for the correct distance between the top of the nipple and finished grade. (Optional: Use an OPW FSA-400 Face Seal Adapter with nipple. Add 3-1/4" to distance from top of nipple to finish grade).

**Step 2 (Optional)**

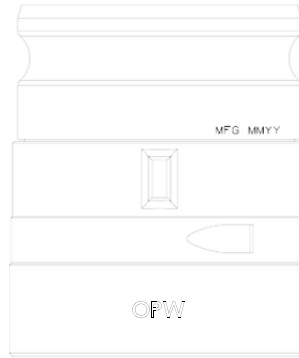
Apply pipe dope to the nipple. Pipe dope is to be non-hardening, gasoline resistant pipe thread seal compound.

**Step 3**

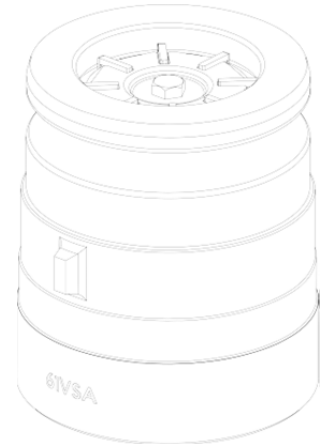
Tighten the Rotatable Adaptor onto the nipple with a torque of 90 ft-lbs min. to 110 ft-lbs max this will be enough torque to seat and seal the gasket. Use an OPW 61SA-TOOL to install rotatable adaptor.

**Static Torque Test**

- Using OPW 200459 Swivel Adaptor Torque Tool and OPW 1711T Vapor Cap, annually verify the static torque of the swivel adaptor by performing California ARB test procedure TP-201.1B. **NOTE:** On aboveground storage tanks, the static torque test must be conducted at least once every three years.



Manufacture: "OPW"  
Date Manufactured: "MFG MMY"  
MM= Month, YY=Year



Product ID: "61VSA"



3250 US 70 Business West  
Smithfield, NC 27577  
Customer Service: 1-(800) 422-2525  
Technical Service and Questions:  
1-(877) OPW-TECH  
www.opwglobal.com



**Installation and Maintenance Instructions**  
**OPW 61JSK-4410, 61JSK-44CB and 71JSK-44MA Jack Screw Kit**

**IMPORTANT:** Please read these warnings and assembly instructions completely and carefully before starting. Failure to do so may cause product failure, or result in environmental contamination due to liquid leakage into the soil, creating hazardous spill conditions.

**IMPORTANT:** Check to make sure the product is intact and undamaged and all parts have been supplied. Never substitute parts for those supplied. Doing so may cause product failure.

**WARNING-DANGER:** Using electrically operated equipment near gasoline or gasoline vapors may result in a fire or explosion, causing personal injury and property damage. Be sure that the working area is free from such hazards, and always use proper precautions.

**NOTE:** At all times when product is in the storage tank keep the riser pipe capped, so the vapors cannot escape into the environment.

**Notice:** OPW products must be used in compliance with applicable federal, state, and local laws and regulations. Product selection should be based on physical specifications and limitations and compatibility with the environment and material to be handled. All illustrations and specifications in this literature are based on the latest production information available at the time of publication. Prices, materials, and specification are subject to change at any time, and models may be discontinued at any time, in either case, without notice or obligation.

Notice: Flex- WorksbyOPW, Inc., VAPORSAVER™ and all other OPW products must be used in compliance with all applicable federal, state, provincial and local laws, rules and regulations. Product selection is the sole responsibility of the customer and/or its agents and must be based on physical specifications and limitations, compatibility with the environment and material to be handled. All illustrations and specifications in this literature are based on the latest production information available at the time of publication. Prices, materials and specifications are subject to change at any time, and models may be discontinued at any time, in either case, without notice or obligation.

This section intentionally left blank.

**Date of manufacture on this product is located on the upper jack screw plate.**

**61JSK and 71JSK Performance Specifications:**

This OPW Jack Screw Kit is designed to lock an OPW 61SO or 71SO Series Overfill Valve or 61T Drop Tube into an OPW 1-2100 or 1-3100 (or Multi-Port 500) Series Spill Container Base below the outlet of the drain valve.

**Torque Specification**

5/16-18 Screw, 3.5 ft-lbs (42 in-lbs) minimum to 5.0 ft-lbs (60 in-lbs) maximum.

4" Nipple, 125 ft-lbs minimum to 250 ft-lbs maximum.

4" NPT Thread, 125 ft-lbs minimum to 250 ft-lbs maximum.

**IMPORTANT:** The figures in this installation and maintenance instruction may contain vapor recovery equipment (including model numbers) that is not certified by the California Air Resources Board (CARB) for a specific Phase I Vapor Recovery System. Please refer to Exhibit 1 of the appropriate CARB Phase 1 Executive Order for a list of certified Phase 1 Vapor Recovery System Equipment.

This section intentionally left blank.

**NOTE:** The 71JSK-44MA contains the parts for both composite and cast iron base applications. For composite base applications use the tall lower cage and proceed to the 61JSK-4410 composite base installation instructions. For cast iron base applications use the thin lower plate and proceed to the 61JSK-44CB cast iron base installation instructions.

**OPW 61JSK-4410 Jack Screw Kit for Composite Base Spill Containers Installation Instructions:**

Figure numbers correspond to step numbers for easy reference.

**Step 1:**

Remove any old or dried pipe dope and metal burrs from top of riser pipe. Apply a gasoline resistant pipe dope on the threads of an OPW FSA-400 Face Seal Adapter and install onto the riser pipe. Torque to 125 ft-lbs min. to 250 ft-lbs max using the OPW 61SATOOL

**Step 2:**

Install the OPW 1-2100, OPW 1-3100, or OPW 500 Series Spill Container in accordance with the OPW Installation Instructions supplied with the product.

**Step 3:** (See Figures 3 and 3A)

Assemble and Install the OPW Drop Tube in accordance with the OPW Installation Instructions supplied with the

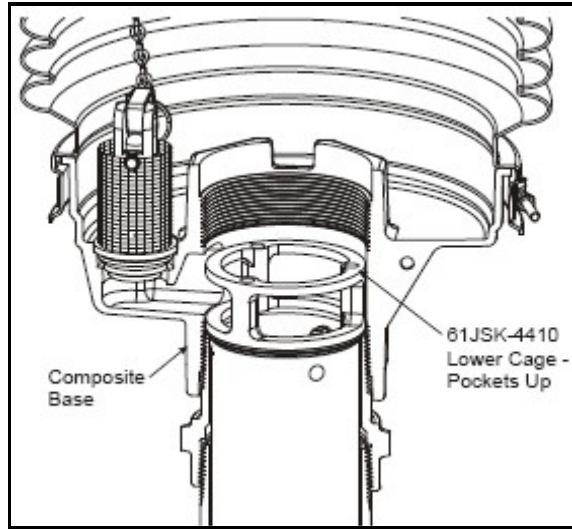
product.

**Step 4:** (See Figure 4)

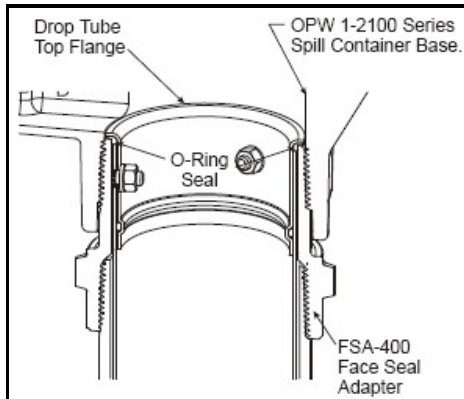
Insert the Jack Screw Lower Cage completely into the spill container base on top of the drop tube flange with the screw pockets facing up.

**Step 5:** (See Figure 5)

Assemble screws into upper plate with the step facing up. Adjust the screws so that the top plate will be located just below the bottom of the threads in the spill container base when the assembly is inserted into the spill container.



**Figure 4**



**Figure 3**

**Step 6:** (See Figure 5)

Install the Jack Screw Assembly into the spill container base. Make sure the bottoms of the three screws are seated in the pockets on the Jack Screw Lower Cage. Apply the supplied thread locker to the threads above the top plate on all three screws on the Jack Screw Top Assembly.

**Step 7:**

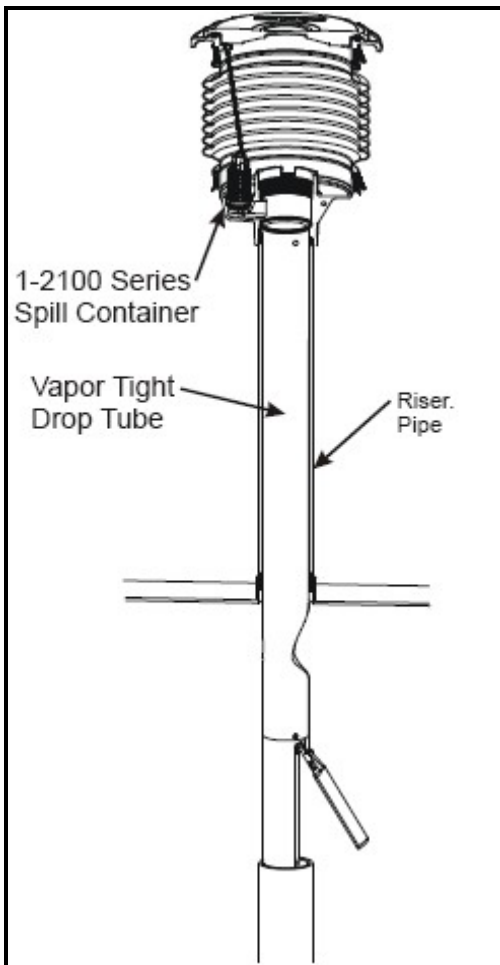
Apply a gasoline resistant pipe dope on the threads of a 4" nipple. Install the 4" nipple into the spill container and tighten securely. (Recommended torque, 4"NPT, 125 ft-lbs min. to 250 ft-lbs max.) Note: The top plate should not be in contact with the nipple at this point. If the nipple hits the top plate while being tightened lower the top plate on the Jack Screw below the threads on the spill container.

**Step 8:** (See Figure 8)

Using a ¼ inch Allen socket, alternately and evenly tighten the three (3) screws on the Jack Screw Assembly until the top plate contacts the bottom of the 4" nipple. Check to make sure the step in the top plate is centered in the nipple. Tighten the three (3) screws evenly and securely with a torque of 3.5 ft-lbs min. to 5.0 ft-lbs max to ensure that the drop tube flange is sealed securely to the Face Seal Adapter.

**Step 9:** (See Figure 9)

Assembly of the Jack Screw Kit is now complete. Proceed to installation of the OPW61SALP-EVR Rotatable Product Adaptor and OPW634TT or OPW634LPC Cap in accordance with the OPW Installation Instructions supplied with the product.



**Figure 3A**

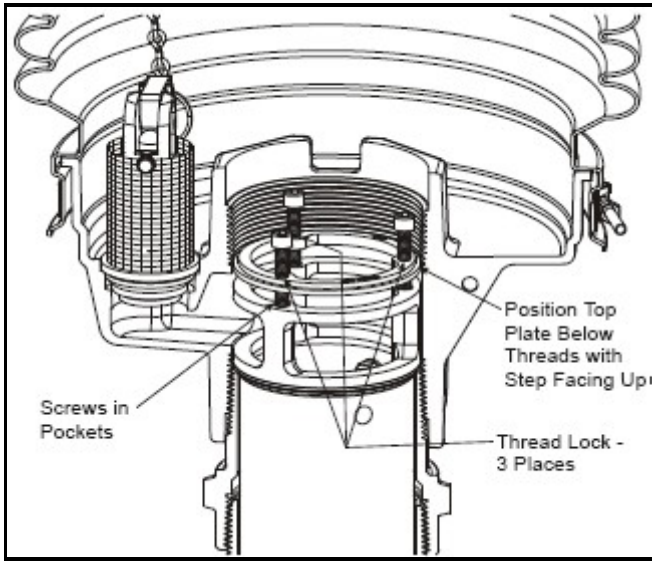


Figure 5

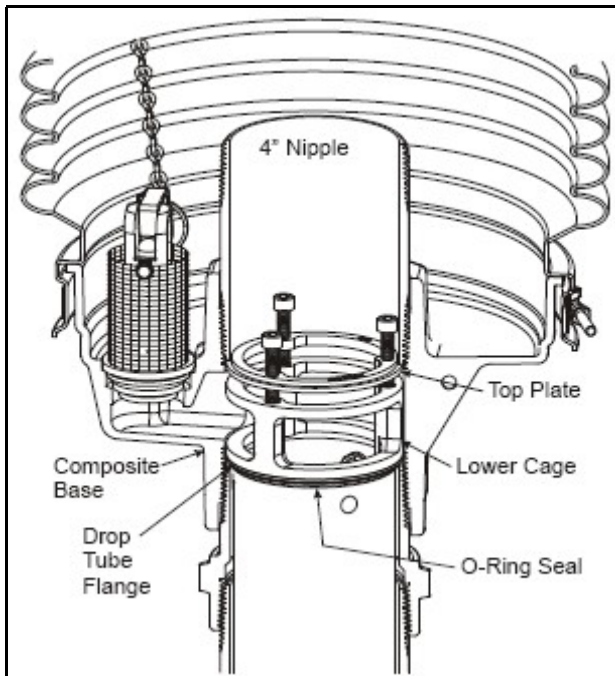


Figure 8

**OPW 61JSK-44CB Jack Screw Kit for Cast Iron Base Spill Containers Installation Instructions:**

Figure numbers correspond to step numbers for easy reference.

**Step 1:**

Remove any old or dried pipe dope and metal burrs from top of riser pipe. Apply a gasoline resistant pipe dope on the threads of an OPW FSA-400 or FSA-400-S Face Seal Adapter and install onto the riser pipe. Torque to 125 ft-lbs min. to 250 ft-lbs max using the OPW 61SA-TOOL.

**NOTE:** Only the cast iron base will work with the FSA-

400-S (Short Face Seal Adapter). With OPW 1-3100 Double Wall Spill Containers the FSA is not required and should not be used.

**Step 2:**

Install the OPW 1-2100, OPW 1-3100, or OPW 500 Series Spill Container in accordance with the OPW Installation Instructions supplied with the product.

**Step 3:** (See Figures 3 and 3A)

Assemble and Install the OPW Drop Tube in accordance with the OPW Installation Instructions supplied with the product.

**Step 4:** (See Figure 4)

Insert the Jack Screw Lower Plate (plate without threads) completely into the spill container base on top of the drop tube flange with the screw pockets facing up.

**Step 5:** (See Figure 5)

Assemble screws into upper plate with the step facing up. Adjust the screws so that the top plate will be located just below the bottom of the threads in the spill container base when the assembly is inserted into the spill container.

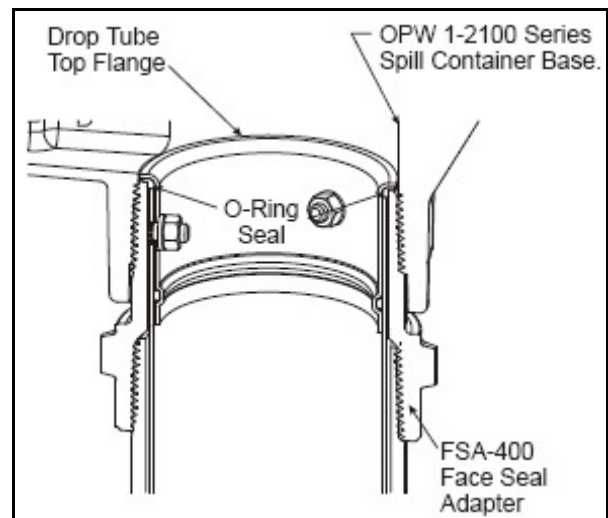


Figure 3

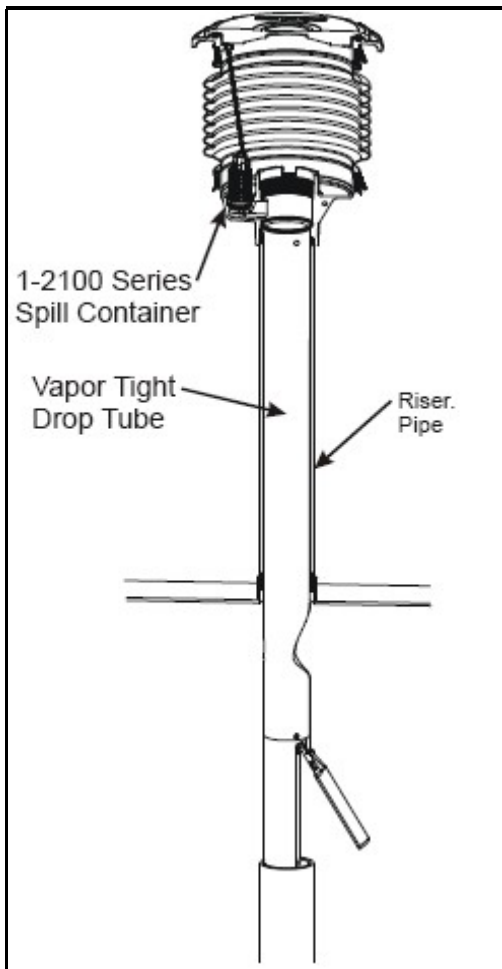


Figure 3A

**Step 7:**

Apply a gasoline resistant pipe dope on the threads of a 4" nipple. Install the 4" nipple into the spill container and tighten securely. (Recommended torque, 4"NPT, 125 ft-lbs min. to 250 ft-lbs max.) **NOTE:** The top plate should not be in contact with the nipple at this point. If the nipple hits the top plate while being tightened lower the top plate on the Jack Screw below the threads on the spill container.

**Step 8:** (See Figure 8)

Using a ¼ inch Allen socket, alternately and evenly tighten the three (3) screws on the Jack Screw Assembly until the top plate contacts the bottom of the 4" nipple. Check to make sure the step in the top plate is centered in the nipple. Tighten the three (3) screws evenly and securely with a torque of 3.5 ft-lbs min. to 5.0 ft-lbs max to ensure that the drop tube flange is sealed securely to the Face Seal Adapter.

**Step 9:** (See Figure 9)

Assembly of the Jack Screw Kit is now complete. Proceed to installation of the OPW61SALP-EVR Rotatable Product Adaptor and OPW634TT or OPW634LPC Cap in accordance with the OPW Installation Instructions supplied with the product.

**Operation and Maintenance**

If a leak develops at the drop tube, re-torque the (3) screws on the Jack Screw. (Torque value: 3.5 ft-lbs min. to 5.0 ft-lbs max.) If this does not correct the leak, check for burrs, clean the sealing surface on the FSA-400 and replace the o-ring on the drop tube. **NOTE:** Loctite 242, thread locker, must be reapplied each time the screws are adjusted.

**IMPORTANT: Leave these instructions with the Station Operator.**

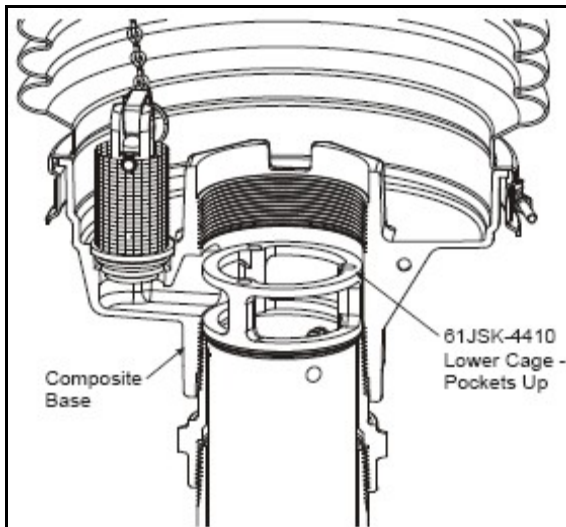


Figure 4

**Step 6:** (See Figure 5)

Install the Jack Screw Assembly into the spill container base. Make sure the bottoms of the three screws are seated in the pockets on the Jack Screw Lower Cage. Apply the supplied thread locker to the threads above the top plate on all three screws on the Jack Screw Top Assembly.

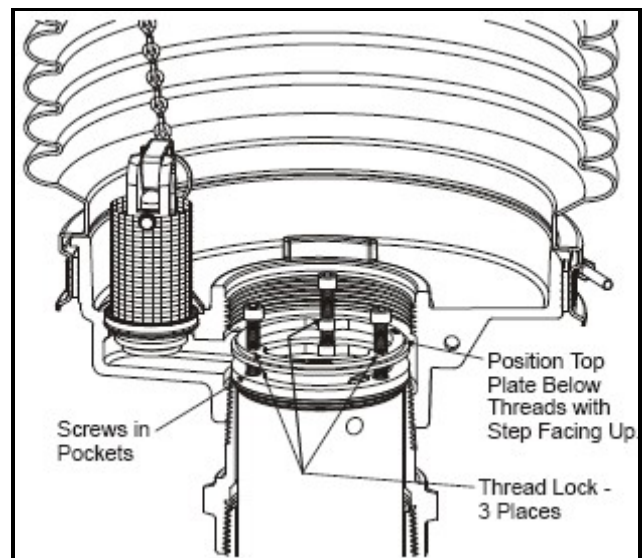


Figure 5



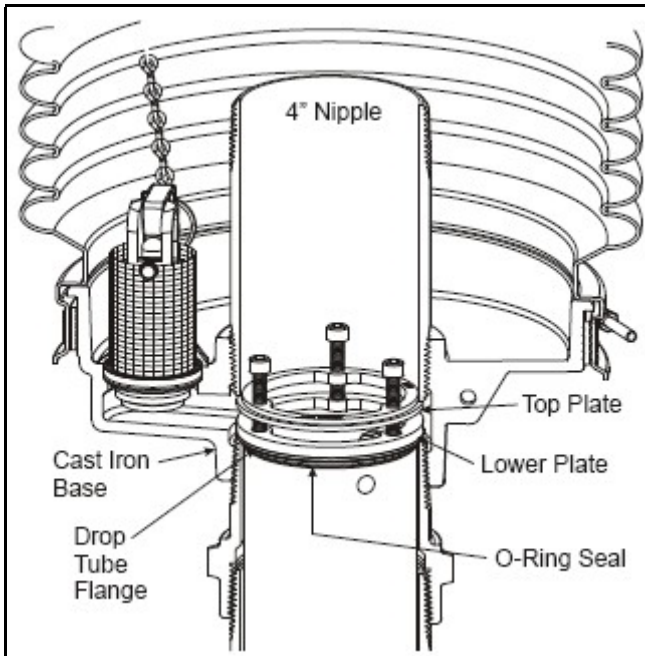


Figure 8

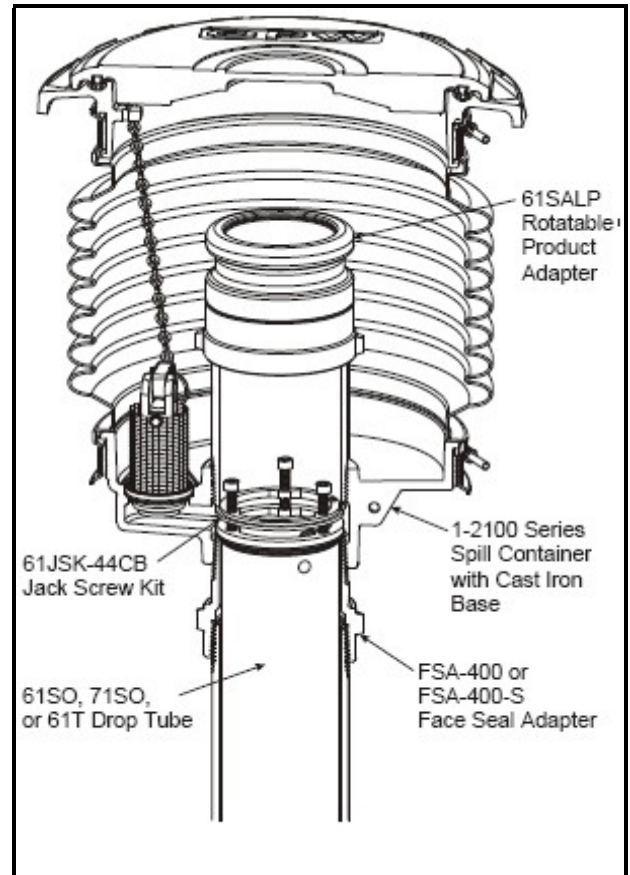


Figure 9 Cast Iron Base

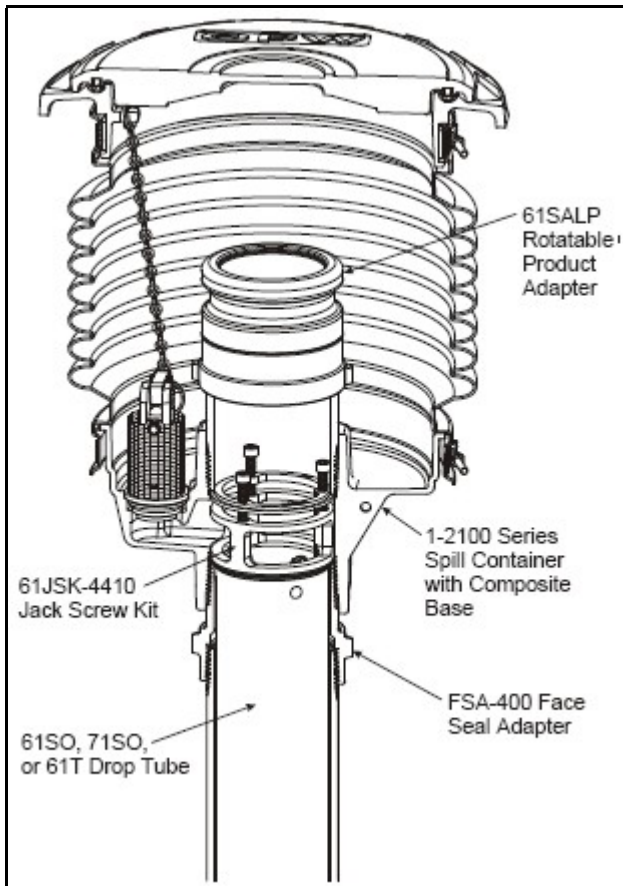
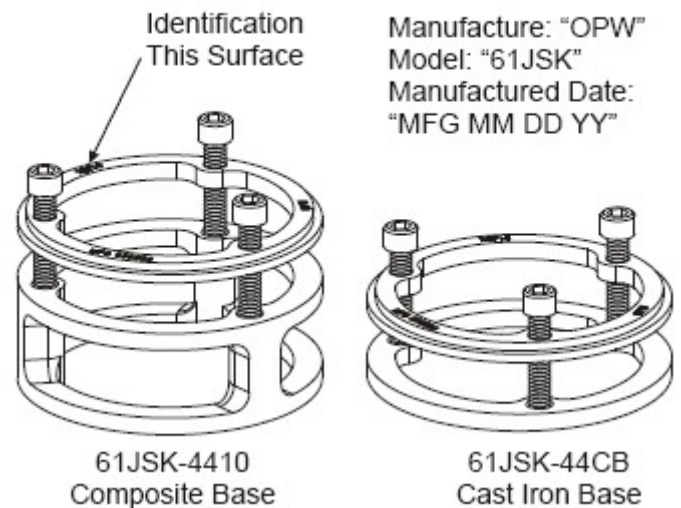


Figure 9 Composite Base

### Alternative Construction



3250 US 70 Business West  
 Smithfield, NC 27577  
 Customer Service: 1-(800) 422-2525  
 Technical Service and Questions:  
 1-(877) OPW-TECH  
 www.opwglobal.com



## **Installation and Maintenance Instructions** **OPW 61JSK-4RMT and 71JSK-4RMT Remote Jack Screw Kit**

Please read these warnings and assembly instructions completely and carefully before starting. Failure to do so may cause product failure, or result in environmental contamination due to liquid leakage into the soil, creating hazardous spill conditions.

**IMPORTANT:** Check to make sure the product is intact and undamaged and all parts have been supplied. Never substitute parts for those supplied. Doing so may cause product failure.

**WARNING-DANGER:** Using electrically operated equipment near gasoline or gasoline vapors may result in a fire or explosion, causing personal injury and property damage. Be sure that the working area is free from such hazards, and always use proper precautions.

**NOTE:** At all times when product is in the storage tank keep the riser pipe capped, so the vapors cannot escape into the environment.

**Notice:** OPW products must be used in compliance with applicable federal, state, and local laws and regulations. Product selection should be based on physical specifications and limitations and compatibility with the environment and material to be handled. All illustrations and specifications in this literature are based on the latest production information available at the time of publication. Prices, materials, and specification are subject to change at any time, and models may be discontinued at any time, in either case, without notice or obligation.

This section intentionally left blank.

Notice: Flex- Works by OPW, Inc., VAPORSAVER™ and all other OPW products must be used in compliance with all applicable federal, state, provincial and local laws, rules and regulations. Product selection is the sole responsibility of the customer and/or its agents and must be based on physical specifications and limitations, compatibility with the environment and material to be handled. All illustrations and specifications in this literature are based on the latest production information available at the time of publication. Prices, materials and specifications are subject to change at any time, and models may be discontinued at any time, in either case, without notice or obligation.

**Date of manufacture on this product is located on the upper jack screw plate.**

**61JSK-4RMT and 71JSK-4RMT Performance Specifications:**

This OPW Jack Screw Kit is designed to lock an OPW Overfill Prevention Valve or OPW Straight Drop Tube into a 4" Pipe Tee and Make a Remote system vapor tight inside a sump.

**Torque Specification**

5/16-18 Screw, 6.0 ft-lbs minimum to 7.0 ft-lbs maximum.

4" Nipple, 125 ft-lbs minimum to 250 ft-lbs maximum. 4"

NPT Thread, 125 ft-lbs minimum to 250 ft-lbs maximum.

**IMPORTANT:** The figures in this installation and maintenance instruction may contain vapor recovery equipment (including model numbers) that is not certified by the California Air Resources Board (CARB) for a specific Phase I Vapor Recovery System. Please refer to Exhibit 1 of the appropriate CARB Phase 1 Executive Order for a list of certified Phase I Vapor Recovery System Equipment.

**This section intentionally left blank.**

**OPW 61JSK-4RMT and 71JSK-4RMT Remote Jack Screw Kit Installation Instructions:**

**Items in 61JSK-4RMT and 71JSK-4RMT Kit:** 62M Cap and Adaptor, Trap Door, Stepped Seal, Flat Seal, Three Screws, Upper Plate and Lower Cage.

**Step 1:**

Install the remote OPW Spill Container in accordance with the OPW Installation Instructions supplied with the product. Note: The FSA-400-(S) is not required. For remote piping follow pipe manufacturers' installation instructions and local agency requirements.

**Step 2:**

Clean the top of the riser pipe coming from the top of UST. Apply a gasoline resistant pipe dope on the threads of an OPW FSA-400-(S) Face Seal Adapter and install onto the riser pipe. Torque from 125 ft-lbs min. to 250ft-lbs max using the OPW 61SA-TOOL.

**Step 3:** (See Figure 2)

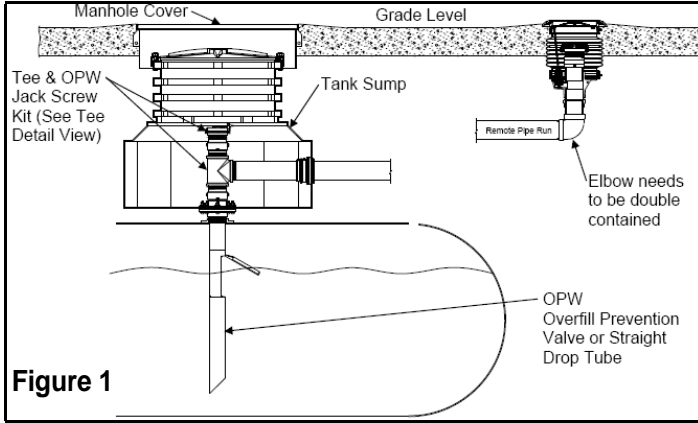
Install the 4" Tee onto the OPW FSA-400-(S) Face Seal Adapter with a gasoline resistant pipe dope, which is installed onto the riser pipe. Torque from 125 ft-lbs min. to 250 ft-lbs max. With the 4" Tee assembled, install the OPW Overfill Prevention Valve or OPW Straight Drop Tube in accordance with the OPW Installation Instruc-

tions supplied with the product.

**Step 4:** (See Figure 2)

Install the Jack Screw assembly into the Tee. Make sure the bottoms of the three screws are seated in the pockets on the Jack Screw Lower Cage (as shown).

**Typical Installation**



**Figure 1**

**Step 5:** (See Figure 2)

Assemble screws into upper plate. Adjust the screws so that the top plate will be located just below the bottom of the threads of the Tee. Apply the supplied thread locker to the threads above the top plate on all three screws of the Jack Screw Top Assembly.

**Step 6:** (See Figure 2)

Apply a gasoline resistant pipe dope on the threads of the pipe nipple. Install the nipple into the Tee and tighten securely. Torque nipple from 125 ft-lbs min. to 250 ft-lbs max.

**NOTE:** The top plate should not be in contact with the nipple at this point. If the nipple hits the top plate while being tightened, adjust the top plate down by turning each screw counterclockwise, lower the top plate on the Jack Screw, and then reinstall the nipple.

**Step 7:** (See Figure 2)

Using a 1/4" Allen wrench, alternately and evenly tighten the three (3) screws clockwise on the Jack Screw Assembly until the Upper Plate contacts the bottom of the 4" nipple. Make sure that the step in the Upper Plate is completely inside of the 4" nipple. Tighten the three (3) screws evenly and securely with 6.0 ft-lbs minimum to 7.0 ft-lbs maximum torque to ensure that the drop tube flange is sealed securely to the OPW FSA-400-(S).

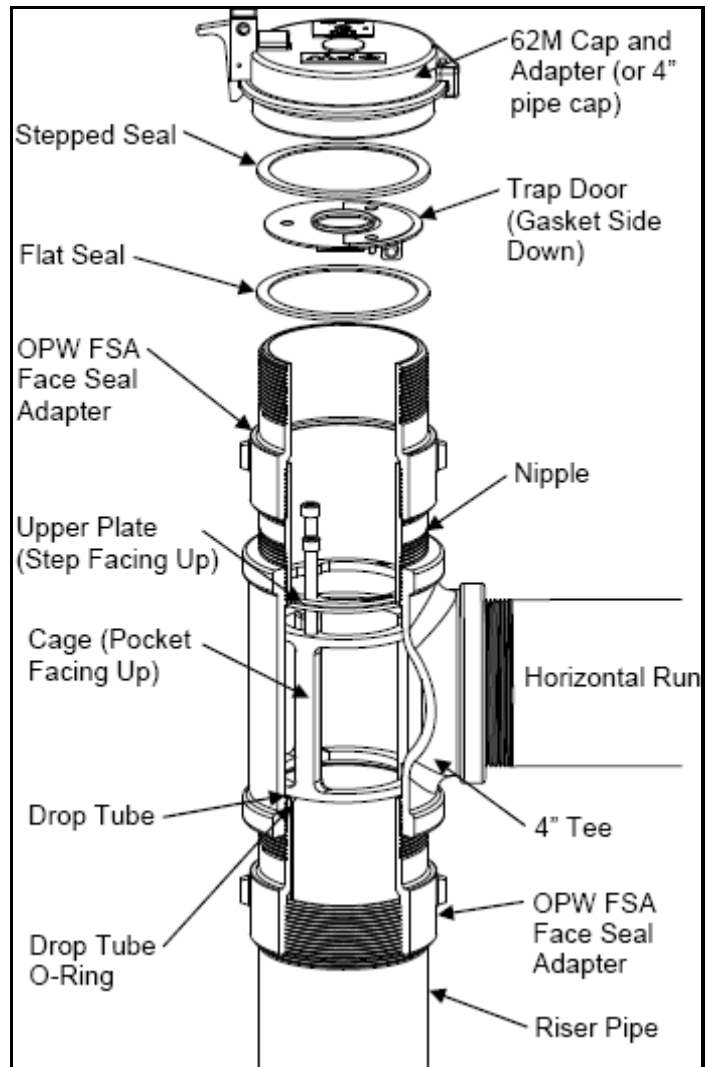
**Step 8:** (See Figures 2 and 3)

To prevent a liquid overflow, the trap door must be in-

stalled on the sticking port of the riser or over the top of the riser that contains an overflow valve that does not have a fixed non-removable cap. Remove the flat seal from the 62M Cap. The stepped seal and flat seal should be installed into the 62M Cap as shown in Figure 3 with trap door assembly gasket side down. If the opening over the 4" Tee is not the sticking port, a permanent 4" pipe cap must be installed.

**Step 9:** (See Figures 2 and 3)

Proceed with installation of the OPW 62M Cap and Adaptor in accordance with the OPW Installation Instructions supplied with the products. Install 62M Cap with trap door assembly and seals onto the top of a FSA-400-(S) Face Seal Adaptor which is installed onto the pipe nipple. Note: Do not remove the pipe plug installed in the top of the cap.



**Figure 2**

**Operation and Maintenance:**

If a leak develops at the drop tube: Re-torque the (3) screws on the Jack Screw. (Torque value: 6.0 ft-lbs min. to 7 ft-lbs max.) If this does not correct the leak, check for burrs, clean the sealing surface on the FSA-400-(S) and replace the o-ring on the drop tube. **NOTE:** Loctite 242, thread locker, must be reapplied each time the screws are adjusted.

**IMPORTANT: Leave these instructions with the Station Operator.**

**Product Identification**

Manufacture: "OPW"

Model: "61JSK"

Manufacture Date: "MFG MM DD YY" where MM=Month, DD=Day and YY=Year.

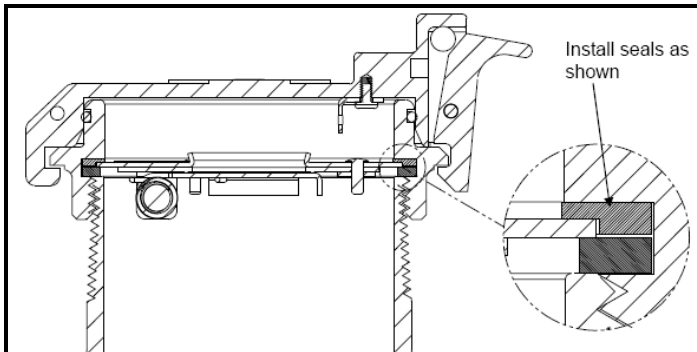


Figure 3

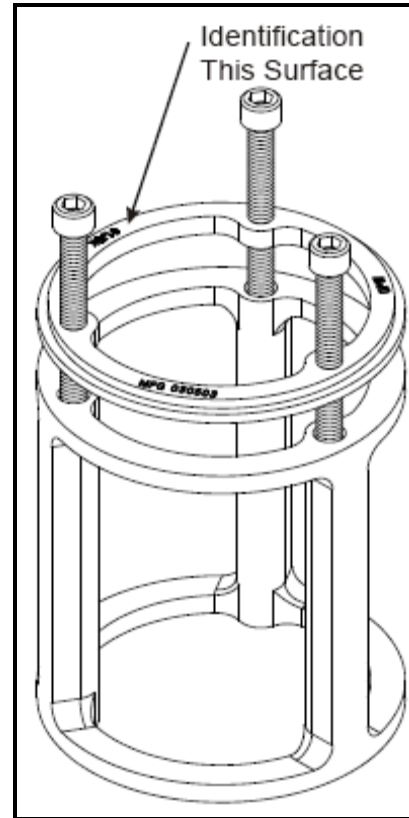


Figure 4



3250 US 70 Business West  
Smithfield, NC 27577  
Customer Service: 1-(800) 422-2525  
Technical Service and Questions:  
1-(877) OPW-TECH  
www.opwglobal.com



## OPW 61JSK-4410 Alternate Remote Fill Configuration Installation and Maintenance Instructions

Please read these warnings and assembly instructions completely and carefully before starting. Failure to do so may cause product failure, or result in environmental contamination due to liquid leakage into the soil, creating hazardous spill conditions.

**IMPORTANT:** Check to make sure the product is intact and undamaged and all parts have been supplied. Never substitute parts for those supplied. Doing so may cause product failure.

**WARNING-DANGER:** Using electrically operated equipment near gasoline or gasoline vapors may result in a fire or explosion, causing personal injury and property damage. Be sure that the working area is free from such hazards, and always use proper precautions.

**NOTE:** At all times when product is in the storage tank keep the riser pipe capped, so the vapors cannot escape into the environment.

This section intentionally blank

**Notice:** OPW products must be used in compliance with applicable federal, state, and local laws and regulations. Product selection should be based on physical specifications and limitations and compatibility with the environment and material to be handled. All illustrations and specifications in this literature are based on the latest production information available at the time of publication. Prices, materials, and specification are subject to change at any time, and models may be discontinued at any time, in either case, without notice or obligation.

This Section Intentionally Blank

**Torque Specification:**

5/16-18 Screw, 3.5 ft-lbs (42 in-lbs) minimum to 5.0 ft-lbs (60 in-lbs) maximum.

4" Nipple, 125 ft-lbs minimum to 250 ft-lbs maximum.

4" NPT Thread, 125 ft-lbs minimum to 250 ft-lbs maximum.

**Note:** All 4" NPT threads are to be torqued progressively lower from the tank up.

**IMPORTANT:** The figures in this installation and maintenance instruction may contain vapor recovery equipment (including model numbers) that is not certified by the California Air Resources Board (CARB) for a specific Phase I Vapor Recovery System. Please refer to Exhibit 1 of the appropriate CARB Phase I Executive Order for a list of certified Phase I Vapor Recovery System Equipment.

This Section Intentionally Blank

**OPW ALTERNATE REMOTE FILL CONFIGURATION  
61JSK-4410 JACK SCREW KIT INSTALLATION INSTRUCTIONS:**

**Step 1**

Remove any old or dried pipe dope and metal burrs from top of riser pipe. Apply a gasoline resistant pipe dope on the threads of an OPW FSA-400 or FSA-400-S Face Seal Adapter and install onto the riser pipe. Torque to 125 ft-lbs min. to 250 ft-lbs max using the OPW 61SA-TOOL.

**Step 2:**

Apply a gasoline resistant pipe dope on the threads of the OPW FSA Adapter. Install a 4" x 4" x 2" tee onto the Face Seal Adapter as shown. Torque to 125 ft-lbs min. to 250 ft-lbs max.

**Step 3:**

Assemble and Install the OPW Drop Tube in accordance with the OPW Installation Instructions supplied with the product.

**Step 4:**

Insert the Jack Screw Lower Cage completely into the tee on top of the drop tube flange with the screw pockets facing up.

**Step 5:**

Assemble screws into upper plate with the step facing up. Adjust the screws so that the top plate will be located just below the bottom of the threads in the top of the tee when the assembly is inserted into the tee.

**61JSK Performance Specifications:**

The alternate remote fill configuration of the OPW Jack Screw Kit is designed to lock an OPW 61SO or 71SO Series Overfill Valve or 61T Drop Tube into a 4" x 4" x 2" tee below the outlet of the drain valve in the spill container base.

**Step 6:**

Install the Jack Screw Assembly into the tee. Make sure the bottoms of the three screws are seated in the pockets on the Jack Screw Lower Cage. Apply the supplied thread locker to the threads above the top plate on all three screws on the Jack Screw Top Assembly.

**Step 7:**

Apply a gasoline resistant pipe dope on the threads of an OPW FSA-400 or FSA-400-S Face Seal Adapter and a 4" nipple. Install the face seal adapter into the tee and tighten securely. (Recommended torque, 4" NPT, 125 ft-lbs min. to 250 ft-lbs max.) (Note: 4" nipples are available from OPW). Install the 4" nipple into the face seal adapter and tighten securely. (Recommended torque, 4" NPT, 125 ft-lbs min. to 250 ft-lbs max.) Install spill container (OPW 1-2100, OPW 1-3100, or POMEKO 500 Series) and/or face seal adapter onto 4" nipple using gasoline resistant pipe dope on the threads in accordance with the OPW Installation Instructions supplied with the product. (Recommended torque, 4" NPT, 125 ft-lbs min. to 250 ft-lbs max.)

Note: The top plate should not be in contact with the face seal adapter at this point. If the face seal adapter hits the top plate while being tightened lower the top plate on the Jack Screw below the threads on the tee.

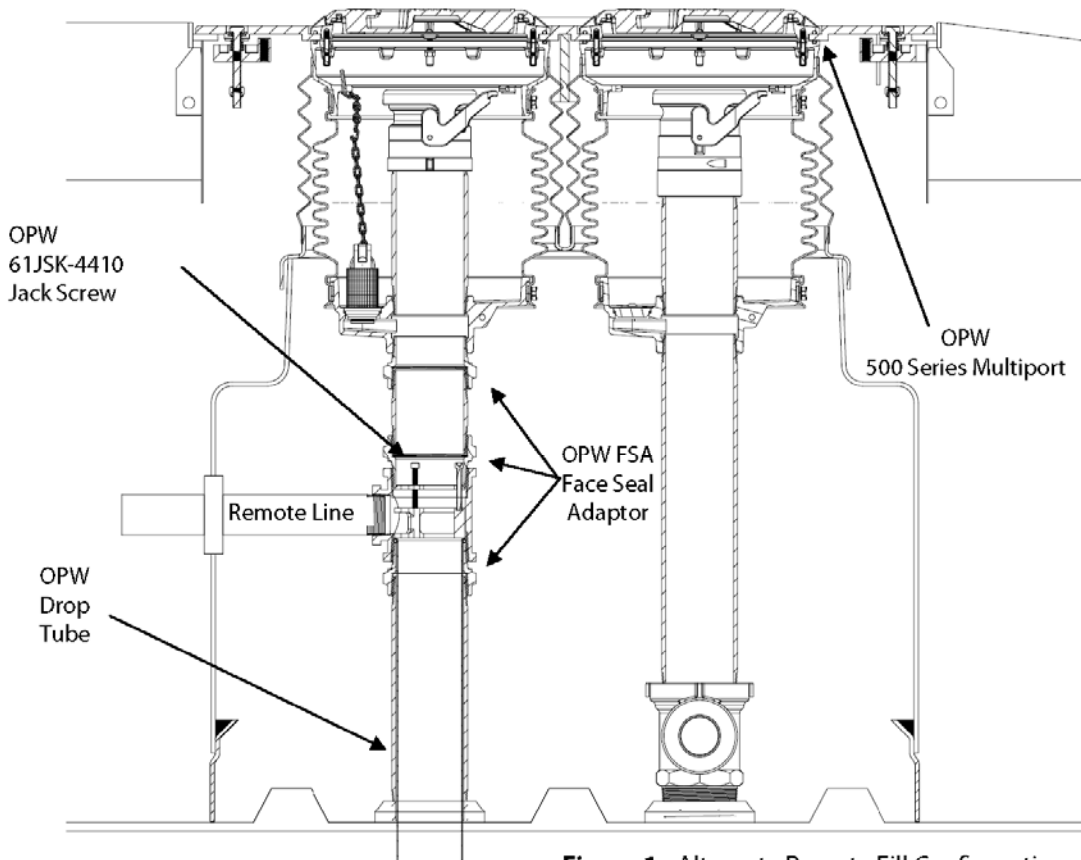
**Step 8:**

Using a ¼ inch Allen socket, alternately and evenly tighten the three (3) screws on the Jack Screw Assembly until the top plate contacts the bottom of the 4" nipple. Check to make sure the step in the top plate is centered in the upper face seal adapter. Tighten the three (3) screws evenly and securely with a torque of 3.5 ft-lbs min. to 5.0 ft-lbs max to ensure that the drop tube flange is sealed securely to the lower Face Seal Adapter. If a remote line is not used in the 2" side of the tee, then the tee must be plugged.

**Operation and Maintenance:**

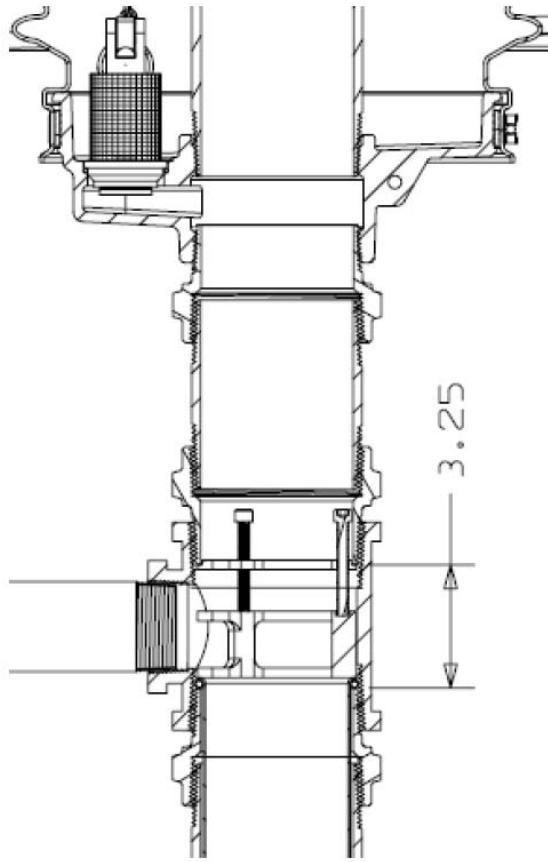
If a leak develops at the drop tube, re-torque the (3) screws on the Jack Screw. (Torque value: 3.5 ft-lbs min. to 5.0 ft-lbs max.) If this does not correct the leak, check for burrs, clean the sealing surface on the FSA and replace the o-ring on the drop tube. **NOTE:** Loctite 242, thread locker, must be reapplied each time the screws are adjusted.

**IMPORTANT: Leave these instructions with the Station Operator.**



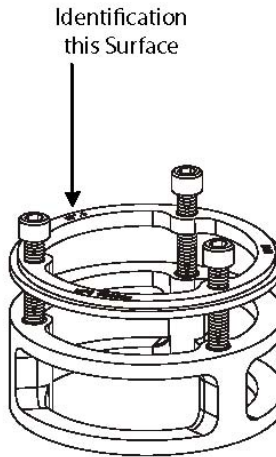
**Figure 1 - Alternate Remote Fill Configuration**





**Alternative Construction**

**Manufacturer:** OPW  
**Model:** 61JSK  
**Manufactured Date:**  
"MFG MM DD YY"



**61JSK-4410 Composite  
Base Alternate Remote Fill**

**Figure 2 - Alternate Remote Fill Cross Section**



**OPW Retail Fueling**  
3250 US 70 Business West  
Smithfield, NC 27577  
Customer Service: 1-(800) 422-2525  
Technical Service and Questions:  
1-(877) OPW-TECH  
www.opwglobal.com

Part Number: 206206  
Issue Date: 09-27-13  
Supersedes: 07-01-13 REV A

Note: OPW/FCS products must be used in compliance with applicable federal, state, provincial and local laws and regulations. Product selection should be based on physical specifications and limitations and compatibility with the environment and material to be handled. OPW/FCS makes no warranty of fitness for a particular use. All illustrations and specifications in this literature are based on the latest production information available at the time of publication. Prices, materials and specifications are subject to change at any time, and models may be discontinued at any time, in either case, without notice or obligation. For complete OPW/FCS warranty information, visit our web site at www.opwglobal.com.



## Installation and Maintenance Instructions OPW FaceSeal Adaptor FSA-400 and FSA-400-S

**IMPORTANT:** Please read these warnings and assembly instructions completely and carefully before starting. Failure to do so may cause product failure, or result in environmental contamination due to liquid leakage into the soil, creating hazardous spill conditions.

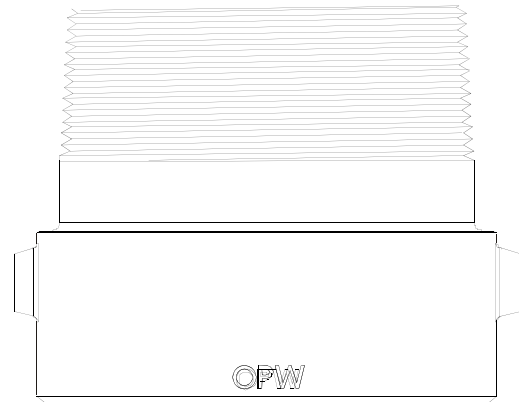
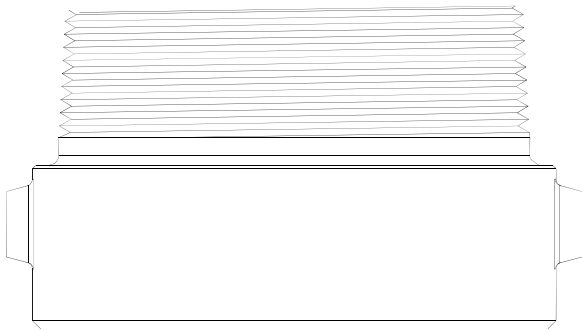
**IMPORTANT:** Check to make sure the product is intact and undamaged and all parts have been supplied. Never substitute parts for those supplied. Doing so may cause product failure.

**WARNING-DANGER:** Using electrically operated equipment near gasoline or gasoline vapors may result in a fire or explosion, causing personal injury and property damage. Be sure that the working area is free from such hazards, and always use proper precautions.

**Notice:** OPW products must be used in compliance with applicable federal, state, and local laws and regulations. Product selection should be based on physical specifications and limitations and compatibility with the environment and material to be handled. All illustrations and specifications in this literature are based on the latest production information available at the time of publication. Prices, materials, and specification are subject to change at any time, and models may be discontinued at any time, in either case, without notice or obligation.

Notice: Flex- WorksbyOPW, Inc., VAPORSAVER™ and all other OPW products must be used in compliance with all applicable federal, state, provincial and local laws, rules and regulations. Product selection is the sole responsibility of the customer and/or its agents and must be based on physical specifications and limitations, compatibility with the environment and material to be handled. All illustrations and specifications in this literature are based on the latest production information available at the time of publication. Prices, materials and specifications are subject to change at any time, and models may be discontinued at any time, in either case, without notice or obligation.

This section intentionally left blank.



**FSA-400**

**Date of manufacture on this product is located on the outside diameter of the body.**

**PRODUCT IDENTIFICATION:**

Manufacture: "OPW"

Model (On opposite side of manufacture): "FSA-400" or "FSA-400-S"

**OPERATION AND MAINTENANCE:**

1. Apply non-hardening, gasoline-resistant, pipe thread seal compound to the threads.
2. Tighten the FSA-400 or FSA-400@ onto the riser with a torque of 125 ft-lbs minimum to 250 ft-lbs maximum. Use the OPW 61SA-TOOL to install.

This Section Intentionally Left Blank.

This page intentionally left blank.



3250 US 70 Business West  
Smithfield, NC 27577  
Customer Service: 1-(800) 422-2525  
Technical Service and Questions:  
1-(877) OPW-TECH  
[www.opwglobal.com](http://www.opwglobal.com)





## OPW 61T Drop Tube Installation and Maintenance Instructions

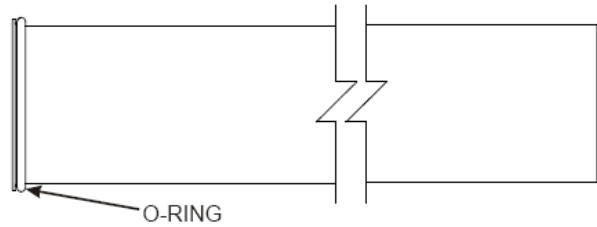
**IMPORTANT:** Please read these warnings and assembly instructions completely and carefully before starting. Failure to do so may cause product failure, or result in environmental contamination due to liquid leakage into the soil, creating hazardous spill conditions.

**WARNING-DANGER:** Using electrically operated equipment near gasoline or gasoline vapors may result in a fire or explosion, causing personal injury and property damage. Be sure that the working area is free from such hazards, and always use proper precautions.

**Notice:** OPW products must be used in compliance with applicable federal, state, and local laws and regulations. Product selection should be based on physical specifications and limitations and compatibility with the environment and material to be handled. All illustrations and specifications in this literature are based on the latest production information available at the time of publication. Prices, materials, and specification are subject to change at any time, and models may be discontinued at any time, in either case, without notice or obligation.

This section intentionally left blank.

Notice: Flex- Works by OPW, Inc., VAPORSAVER™ and all other OPW products must be used in compliance with all applicable federal, state, provincial and local laws, rules and regulations. Product selection is the sole responsibility of the customer and/or its agents and must be based on physical specifications and limitations, compatibility with the environment and material to be handled. All illustrations and specifications in this literature are based on the latest production information available at the time of publication. Prices, materials and specifications are subject to change at any time, and models may be discontinued at any time, in either case, without notice or obligation.



**Installation Instructions:**

1. Cut the tube to a length so that it is not more than 6" from the bottom of the tank. The tube can be cut at a 45-degree angle or per local codes or requirements. File off any sharp burrs.

**Operation and Maintenance:**

**Annually:** Test the drop tube seal with CARB procedure TP-201.1C or TP-201.1D. If the drop tube seal passes testing, no further maintenance is required. If the drop tube seal fails testing, replace the drop tube seal with OPW P/N: H11931M for 4" Tubes. Re-test the drop tube seal with CARB procedure TP-201.1C or TP-201.1.



3250 US 70 Business West  
Smithfield, NC 27577  
Customer Service: 1-(800) 422-2525  
Technical Service and Questions:  
1-(877) OPW-TECH  
[www.opwglobal.com](http://www.opwglobal.com)

## **61SO Vapor Tight Overfill Prevention Valves Assembly, Installation and Maintenance Instructions**

# IMPORTANT INFORMATION FOLLOW ALL INSTRUCTIONS

Please read these warnings and use and assembly instructions completely and carefully before starting. Failure to do so may cause product failure, or result in environmental contamination due to liquid leakage into the soil, creating hazardous spill conditions.

Notice: Flex- Worksby OPW, Inc., VAPORSAVER™ and all other OPW products must be used in compliance with all applicable federal, state, provincial and local laws, rules and regulations. Product selection is the sole responsibility of the customer and/or its agents and must be based on physical specifications and limitations, compatibility with the environment and material to be handled. All illustrations and specifications in this literature are based on the latest production information available at the time of publication. Prices, materials and specifications are subject to change at any time, and models may be discontinued at any time, in either case, without notice or obligation.

This section intentionally left blank.

**Date of manufacture on this product is located on the flat area of the valve body, under float.**

### **GENERAL INSTRUCTIONS**

The OPW 61SO Overfill Prevention Valve is designed for tight fill, gravity drop applications to help prevent accidental or intentional overfilling of underground storage tanks. It is installed in the UST drop tube in place of a standard drop tube.

The main 61SO valve closes when liquid level is at 95% of the top of the tank reaches the initial shut off point. A small bypass valve remains open to allow the delivery hose to drain at 3-5 gallons per minute. If the delivery truck valve is not closed after initial shut-off, the bypass valve will close and will restrict all fuel delivery to ensure that the top of the tank is not wetted per EPA requirements.

The 61SO EVR approved models of the 61SO are designed to be installed with the following OPW products: Face Seal Adaptor, OPW Spill Container or Multi-port, Jack Screw Kit, Rotatable Product Adaptor, and Product Cap.

### **IMPORTANT**

Read these assembly and installation instructions completely and carefully prior to starting. Check to make sure all parts have been provided. Use only the parts supplied; substitution of parts may cause product failure.

Failure to follow instructions may cause improper product operation or premature failure which may permit storage tank overfill. An overfilled storage tank may create hazardous conditions and/or environmental contamination.

### **CAUTION**

**Do not remove elastic band from around float until instructed to do so, as damage to valve may result.**

### **WARNING**

**Failure to properly connect delivery hose and elbow, and/or disconnecting a liquid filled delivery hose or elbow will result in a hazardous spill, which may result in personal injury, property damage, fire, explosion, and water and soil pollution.**

- Make sure all connections, including the hose and elbow connections, between storage tank and transport are securely coupled.
- Make sure the lip seal and/or all gaskets in the delivery elbow are properly in place to prevent spills.
- Do not operate with damaged or missing parts, which prevent tight connections.

**Normal Operation:** A Hose "Kick" and reduced flow

**This section intentionally left blank.**



signal that the tank is full. Close transport delivery valve and drain hose into tank before disconnecting any hose fitting.

**Overfilled Tank:** Failure of the hose to drain after closing the delivery valve signals an overfilled tank. Do Not disconnect any delivery hose fitting until the liquid level in the tank has been lowered to allow the hose to drain into the tank.

### WARNING

**In the event you are splashed with fuel remove wet clothing immediately. Skin contact with gasoline can cause chemical burns and may result in inhalation of vapors that may be fatal. Never go inside confined areas after being splashed and never go near ignition sources.**

### IMPORTANT

Determine if the underground storage tank is equipped with a ball float vent valve, as illustrated in Figure 16. In all systems, the shut-off point of the 61SO must be reached before the ball float reduces flow to ensure proper overfill valve operation.

### TOOLS NEEDED FOR INSTALLATION AND ASSEMBLY:

1. Drill
2. A sharp 1/8" pilot drill bit
3. A sharp 5/16" drill bit
4. Tape measure
5. Hacksaw or cut-off saw, fine tooth; 24 teeth/inch
6. Fine half round file
7. Screwdriver - Phillips blade
8. 1/2" Wrench or socket
9. Two-part sealant (Supplied)
10. Torque Wrench

### WARNING

**Using electrically operated equipment near gasoline or gasoline vapors may result in fire or explosion, causing personal injury and property damage. Check to assure the working area is free from such hazards, and always use proper precautions.**

**IMPORTANT:** The figures in this installation and maintenance instruction may contain vapor recovery equipment (including model numbers) that is not certified by the California Air Resources Board (CARB) for a specific Phase I Vapor Recovery System. Please refer to Exhibit 1 of the appropriate CARB Phase I Executive Order for a list of certified Phase I Vapor Recovery System Equipment.

### HOW TO LOCATE THE POSITION OF THE 61SO AT 95% TANK CAPACITY (Shut-off points can be adjusted to any capacity to comply with AHJ Requirements)

The length of the upper tube and the placement of the 61SO valve body determine the shut-off point. Following the standard instructions for the OPW 61SO will provide for initial shutoff at 95%. In all cases, the upper tube length must be a minimum of 6-1/2" plus the length of the riser pipe. All length measurements are in inches.

### INSTRUCTIONS

- 1) Find tank capacity (in gallons) from tank calibration chart provided by tank manufacturer.
- 2) Calculate 95% of capacity
- 3) Locate the 95% volume number on the tank calibration chart.
- 4) Find the dipstick number (X) which corresponds to the 95% tank volume. And, find the dipstick number (Y) which corresponds to the 100% volume.
- 5) Subtract the dipstick number (X) from the tank diameter (Y) to find the upper tube reference number (Z).

$$(Y) - (X) = (Z)$$

- 6) Subtract 2" from (Z) to find the upper tube depth (C).

$$(Z) - 2" = C$$

- 7) Is C less than 6-1/2"?

**NO** Upper tube length is C plus the distance from the top of the Face Seal Adaptor installed on the riser pipe to the inside, top lip of the storage tank (A).

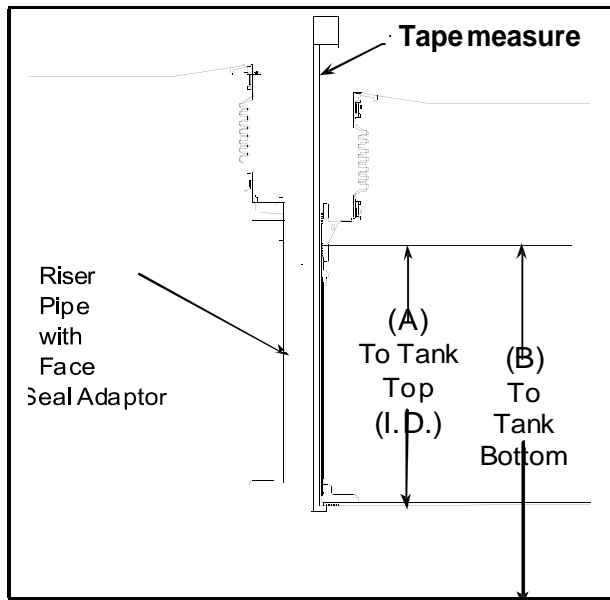
$$\text{Upper Tube Length} = C + (A)$$

**YES** Upper tube length is 6-1/2" plus the riser pipe measurement (A).

$$\text{Upper Tube Length} = 6-1/2" + (A)$$

**NOTE: You must find the actual tank capacity number that correlates to the 6-1/2" + (A) depth for the station records. This number may also be used for the purposes of calibrating an electronic tank level system.**

®Registered T.M. - Owens Corning Fiberglass Corporation



**EXAMPLE**

- 1) For an Owens-Corning Model G-3 Fiberglass® Tank Calibration Chart:  
 Tank Capacity - 10,000 gal., nominal 9,403 gal.  
**NOTE: Use actual capacity only**
- 2) 95% of actual tank capacity = 0.95 x 9403 gal. = 8933 gal.
- 3) The closest number which is less than 8933 gal. is 8910 gal. Choosing the closest number less than 95% of actual capacity ensures that the initial shutoff will occur when the tank is no more than 95% full.
- 4) The calibration chart reading of 8910 gal. corresponds to a dipstick measurement of 82".
- 5) Dipstick number (X) = 82"  
 Tank diameter (Y) = 92"  
 $(Y) - (X) = (Z)$        $(92" - 82" = 10")$   
 $(Z) = 10"$
- 6)  $(Z) - 2" = C$        $(10" - 2" = 8")$   
 $C = 8"$
- 7) Is 8" less than 6-1/2"?

**NO** Measure the distance from the top of the FSA-400 Face Seal Adaptor installed on the riser pipe to the inside, top lip of the storage tank and obtain measurement (A).

Upper tube length = C + (A)

**ASSEMBLY INSTRUCTIONS**

**IMPORTANT:** Each of the numbered steps in the installation instructions are designed as a CHECKLIST to ensure proper installation and trouble free operation of the OPW 61SO Overfill Prevention Valve.

Read and follow these steps carefully, checking them off as you proceed.

Figure numbers correspond to step numbers for easy reference.

**STEP 1: MEASURE**

Install the OPW Face Seal Adaptor and the OPW Thread-on Spill Container on the Fill Riser (Refer to the Installation Instructions Supplied with the Spill Container). Insert a tape measure through the riser pipe and hook it under the inside of the tank in the lengthwise direction.

Measure the distance from the top of the Face Seal Adaptor threads inside the base of the spill container bucket just below the drain valve outlet window to the inside, top lip of the storage tank (Dim. "A") **(See Figure 1 & 1A).**

The top flange on the 61SO will rest on the Face Seal Adaptor just below the drain valve outlet, and be locked in place between the Face Seal Adaptor and the 4" nipple that is installed in the spill container with the Jack Screw Kit **(See Figure 1A)**. (For riser pipe configurations other than that shown, consult installation drawings or use other necessary means to measure Dimension "A").

Using a tape measure, measure the distance from the top of the Face Seal Adaptor in the spill container to the bottom of the tank (Dim. "B").

**IMPORTANT:** Inspect the riser pipe for any foreign material. Over spray from tank relining or any internal burrs inside of pipe must be removed prior to installation. Failure to have an unobstructed riser pipe may prevent proper installation and operation of the valve. The 61SO is designed for installation into schedule 40 riser pipes. The 61SO cannot be installed into schedule 80 riser pipes.

**STEP 2: MARK THE TUBE**

Use the result from Step 1 and **HOW TO LOCATE THE POSITION OF THE 61SO AT 95% TANK CAPACITY** to mark the upper tube. Measure the distance from the point where the upper tube and valve body meet. For "C" measurements greater than 6- 1/2" use tape measure to mark the calculated upper tube length onto the upper tube.

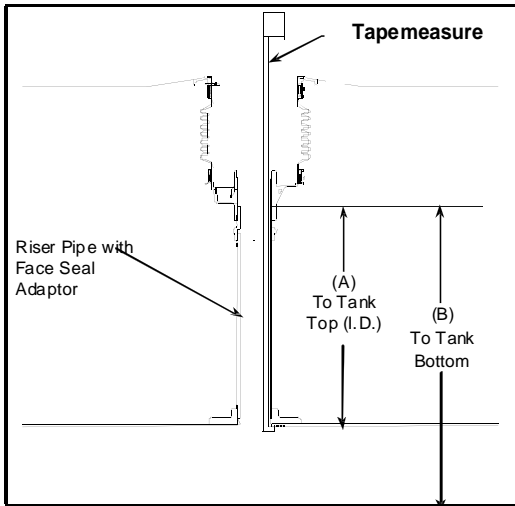


Figure 1

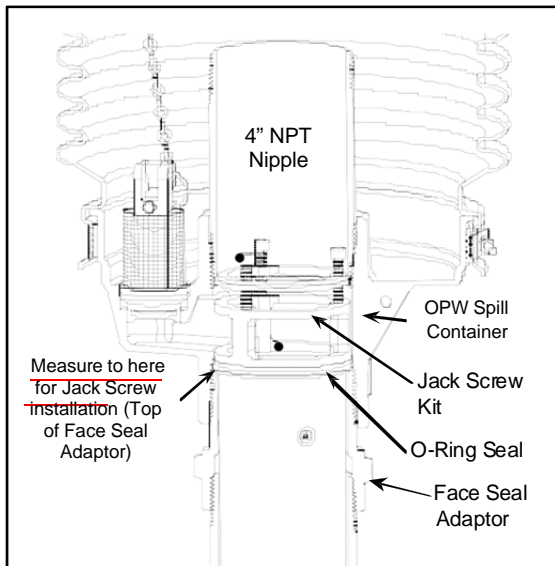


Figure 1A

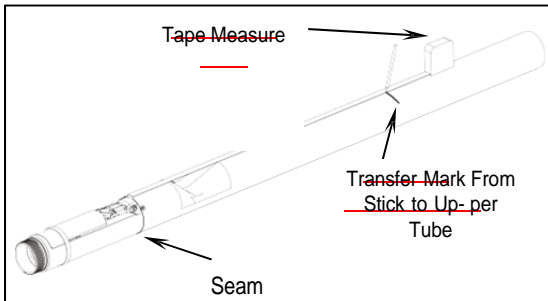


Figure 2

(For "C" less than or equal to 6-1/2" only)

**STEP 3: CUT THE UPPER DROP TUBE**

Carefully saw through the tube squarely, at the mark made in Step 2. Use a hacksaw with a new fine-tooth blade. Rotating the upper tube as the sawing progresses will minimize run out and ensure a square 90-degree cut. A piece of paper, taped square with the tube or a hose clamp can be used as guides for making a square cut.

**CAUTION - DO NOT use a pipe or tubing cutter to cut the upper drop tube, this may damage the tube, causing it to be out of round thereby prohibiting assembly of the unit.**

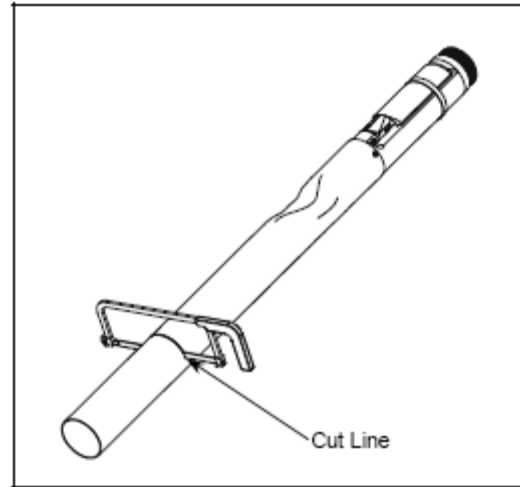


Figure 3

**STEP 4: FILE THE UPPER DROP TUBE**

File the upper tube square, and remove any burrs or rough edges. Make sure the cut is flat and square.

**IMPORTANT:** Carefully file a good chamfer on the inside edge of the drop tube to provide a lead-in for the o-ring and inlet tube installed in Step 6.

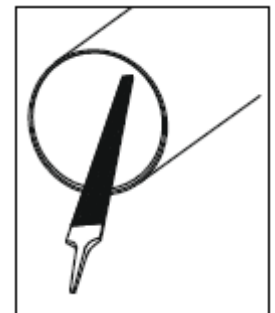


Figure 4

**CAUTION:** Failure to properly apply and cure sealant may result in a failure of a pressure decay leak test.

**STEP 5: APPLY SEALANT**

Prepare sealant by thoroughly mixing 1/3 of each packet together until color is uniform. Generously apply sealant to the inside diameter of the upper drop tube. Make sure coverage is completely around the tube as shown in Fig. 5.

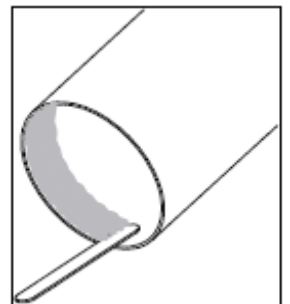


Figure 5

**STEP 6: INSTALL INLET TUBE**

Install o-ring in the o-ring groove of inlet tube (DO NOT USE GREASE). Insert the inlet tube into the upper tube until it seats against the flange on the upper inlet tube.

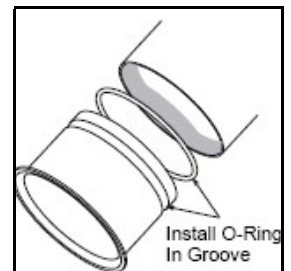


Figure 6

**STEP 7: DRILL HOLES**

With the inlet tube in place, carefully drill (3) 1/8" diameter pilot holes through the drop tube and inlet tube at three locations at 120 degree intervals around the tube, 1 inch below the flange. Using the pilot holes, drill (3) 5/16" dia. holes through the tubes. Remove the burrs from the drilling operation from the inside of the drop tube assembly with a fine half round file.

**IMPORTANT:** A 5/16" drill bit must be used. Do not substitute any other size drill bit.

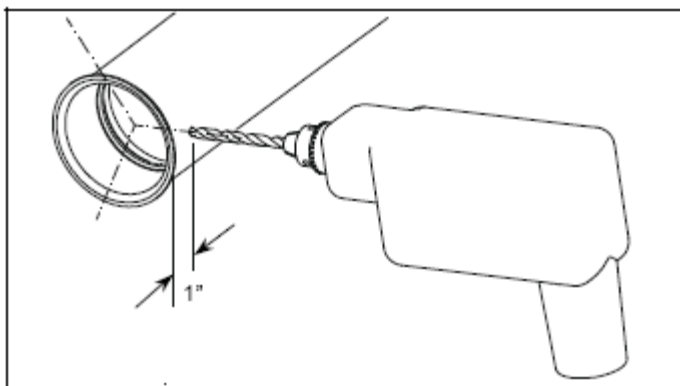


Figure 7

**STEP 8: ASSEMBLE AND SEAL CLINCH STUDS**

Loosely assemble the three (3) clinch studs, lock washers, and nuts in holes. Do not tighten at this time. Mix up a small amount of sealant. Generously apply sealant underneath each clinch stud head, each nut, and on the outside of the tube around the holes.

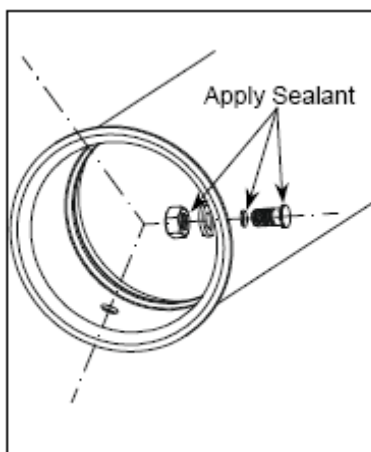


Figure 8

**STEP 9: TIGHTEN SELF-CLINCHING STUDS**

Tighten clinch studs securely with a 1/2" wrench. Use only the self-clinching studs that are supplied with the unit. Seating torque is 11.5 ft-lbs min. to 13.5 ft-lbs max. Do not over tighten. Note: Failure to properly apply and cure the sealant may result in a failure of a pressure decay leak test.

**STEP 10: LOWER TUBE ASSEMBLY**

If a vise is used, clamp on the valve body casting only to avoid damage to the float. Mix the remaining sealant until the color is uniform. Using the mixing stick, gener-

ously apply sealant to the first 6 male threads on the valve body as shown in figure 10. Make sure coverage is completely around the threads, and work the sealant down into the thread profile. Quickly thread the lower tube onto the valve body. Tighten the tube securely by hand or with a strap wrench. Remove excess sealant and smooth sealant bead with water moistened mixing stick.

**IMPORTANT:** Allow sealant (epoxy) to cure for 24 hours before installing into tank.

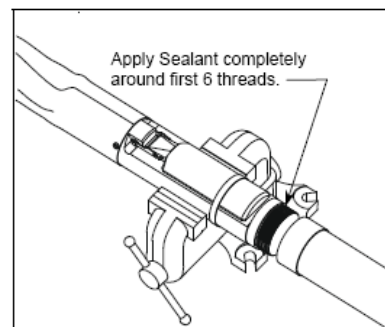


Figure 10

**NOTE:** Before installing the valve in the tank, a pressure test can be performed on the valve to check for vapor tightness. Seal off both ends of the tube with inflatable plumber's plugs. Apply a maximum 10" W.C. (1/3 PSI) air pressure. If pressure does not hold and a leak can be located with soap solution, do not install the valve. Send the valve back to OPW for warranty evaluation. Caution: Do not over-pressure. Excess pressure can damage the valve.

**STEP 11: CUT LOWER TUBE AT 45 DEGREE**

Measuring from the underside of the inlet tube flange, mark the overall length of the drop tube a distance of (B) minus 6" or as per local codes or requirements. Determine dimension (B) from the measurements taken in Step 1, Figure 1 (Top of the Face Seal Adaptor below the drain valve outlet in the spill container to the bottom of the tank). Saw off the excess tube at a 45-degree angle, and file off any sharp burrs (Refer to Figure 16). Optional: Install the OPW Tank Bottom Protector on the lower tube (Refer to Installation instructions supplied with the Tank Bottom Protector).

**STEP 12: PREPARE FILL RISER FOR VALVE INSERTION**

**IMPORTANT:** Inspect the riser pipe for any foreign material. Over spray from tank relining or any internal burrs inside of pipe must be removed prior to installation. Failure to have an unobstructed riser pipe may prevent proper installation or operation of the valve. Thoroughly clean top of riser pipe.

**IMPORTANT: Before installing the valve, allow sealant to cure for 24 hours.**

**STEP 13: REMOVE ELASTIC BAND**

Remove the elastic band securing the float to the valve body. The float will move into an outward position.

**STEP 14: INSERT DROP TUBE**

Make sure the O-Ring gasket is under the flange of the inlet tube. Hold the float down against the valve body and slowly insert the drop tube overfill valve into the riser pipe. Do not force valve into the riser pipe. If any obstruction or foreign matter interferes with smooth insertion of the valve, the riser pipe must be cleared.

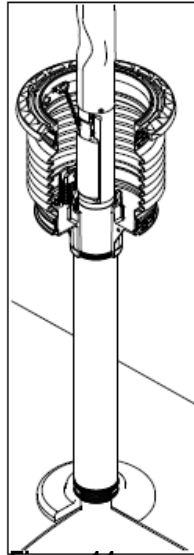


Figure 14

**WARNING** Failure to follow the assembly and installation instructions or use of excessive force to insert the OPW 61SO will VOID THE WARRANTY!

Difficulty in removing the existing fill tube (if there is one) means there may be an obstruction in the riser pipe. Look for burrs, deformations, excess tank lining material or other projections that may interfere with easy insertion of the OPW 61SO. The 61SO is designed for insertion into schedule 40 pipe. If schedule 80 pipe has been used for the riser, the 61SO cannot be installed. If seamed pipe has been used, the internal weld bead may interfere with the OPW 61SO and prevent installation. If the OPW 61SO won't slip in easily **DON'T FORCE IT!** Damage to the valve may result if excess force is used. Examine the riser pipe carefully; determine the nature of the obstruction; take appropriate steps to remove it.

**STEP 15: CHECK INSTALLATION**

Insert the drop tube all the way into the tank until the flange and gasket seat onto the top of the Face Seal Adaptor. The float will swing out into the operating position as it passes into the tank. Make sure that the float is aligned along the length of the tank. The length of the tank can easily be determined by locating other manholes or pump boxes that are installed around other tank fittings. Look into the drop tube and align the deflector with the length of the tank.

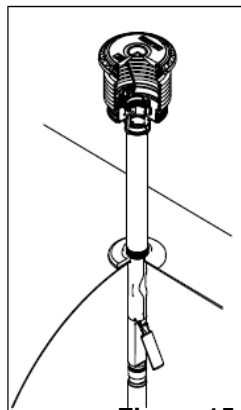


Figure 15

**CAUTION:** No obstruction in the tank can be within 13" from the center of the riser pipe or the valve may not operate properly.

**STEP 16: ALIGN VALVE**

Install the OPW Jack Screw Kit and a 4" nipple to lock the valve in place. Refer to the Installation Instructions supplied with the Jack Screw Kit. Install the Rotatable Product Adaptor (Refer to Installation Instructions supplied with the Rotatable Product Adaptor.) Make sure that the valve does not rotate while tightening the adaptor by observing the position of the deflector. The valve must remain aligned along the length of the tank as in Step 15. Repeat this step as necessary to assure proper valve alignment.

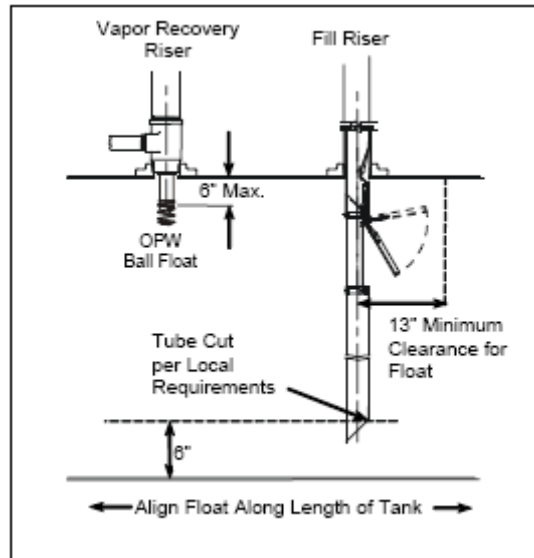


Figure 16

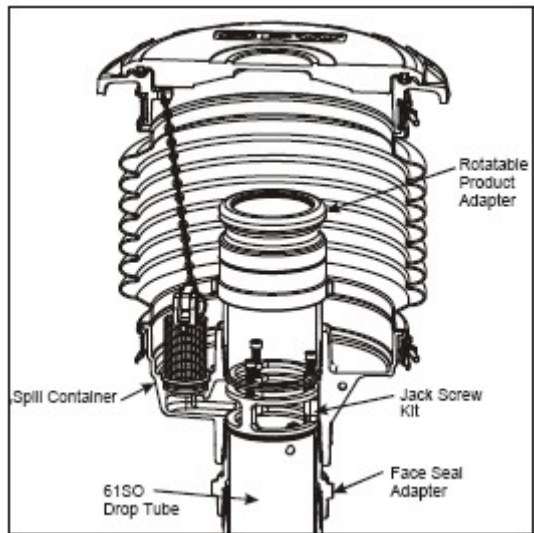
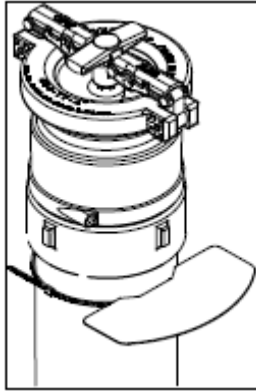


Figure 16A

**STEP 17: INSTALL WARNING PLATE**

Slide the tie wrap over the warning plate ears and position warning plate against riser pipe approximately 1" below the adaptor. Tighten the tie wrap securely. The valve is now fully installed and in operating position.



**STEP 18: VALVE REMOVAL**

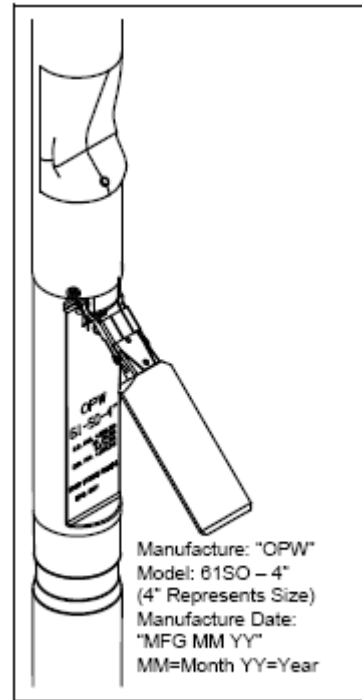
The valve can be removed for tank leak testing, inspection, etc., by removing the Rotatable Product Adaptor, the 4" nipple, and the Jack Screw Kit. **Figure 17** Reinstall per the above instructions.

**STEP 19: ELECTRONIC LIQUID LEVEL MONITORING**

If an electronic level monitor is installed, it must be calibrated to match the top of the 61SO valve body, which must correlate with 95% of the actual tank capacity.

**PREVENTATIVE MAINTENANCE**

Annually, inspect the flapper in the 61SO to see that it is open by looking down the drop tube opening. Test the 61SO drop tube seals with CARB procedure TP-201.1D. If the drop tube seal passes testing, no further maintenance is required. If the drop tube fails testing, replace the drop tube seal with OPW P/N: H11931M for 4" Tubes. Re-test the 61SO drop tube with CARB procedure TP-201.1D. If this does not correct the leak the 61SO needs to be replaced.



**Product Identification**

**CAUTION: Do not insert any foreign object into drop tube if flapper is in the closed position. For example a tank level measuring stick. This will damage the valve and void the Warranty. ALWAYS check flapper location before "sticking" the tank. If flapper is in the closed position the tank is either over filled and you need to wait until the liquid level goes down or the 61SO is damaged and needs to be replaced.**

**61SO Performance Specifications:**

This Overfill Prevention Valve has been manufactured and tested to, and met, the following California specifications. Performance Requirement: Leak rate to be less than or equal to 0.17 CFH @ 2.0" W.C.

**Torque Specification:**

Self-Clinching Studs, 5/16-8 UN thread, 11.5 ft-lbs minimum to 13.5 ft-lbs maximum.

**IMPORTANT: Leave these installation instructions and maintenance procedures with the station operator.**

This page intentionally left blank.



## 71SO Overfill Prevention Valves and 71SO Testable Overfill Prevention Valves Installation and Maintenance Instructions

# IMPORTANT INFORMATION FOLLOW ALL INSTRUCTIONS

Please read these warnings and use and assembly instructions completely and carefully before starting. Failure to do so may cause product failure, or result in environmental contamination due to liquid leakage into the soil, creating hazardous spill conditions.

**OPW Standard Product Warranty Tag:** Notice: FlexWorks by OPW, Inc., VAPORSAVER™ and all other OPW products must be used in compliance with all applicable federal, state, provincial and local laws, rules and regulations. Product selection is the sole responsibility of the customer and/or its agents and must be based on physical specifications and limitations, compatibility with the environment and material to be handled. All illustrations and specifications in this literature are based on the latest production information available at the time of publication. Prices, materials and specifications are subject to change at any time, and models may be discontinued at any time, in either case, without notice or obligation.

OPW warrants solely to its customer (the initial purchaser and any subsequent purchasers within the warranty period) that the following products sold by OPW will be free from defects in materials and workmanship under normal use and conditions for the periods indicated:

PRODUCT	WARRANTY PERIOD
FlexWorks Primary Pipe	10 years from date of manufacture
All Products and replacement parts installed in the State of California Certified to California CP-201 and/or CP-206 Standards*	1 year from date of installation (proof of purchase from certified contractors/technicians required) OPW warrants ongoing compliance with the standards and specifications for the duration of the warranty period required by the State of California; this limited warranty is under the condition the equipment was installed and maintained by trained and certified contractors/technicians unless noted in Installation Manual.
All other Products and replacement parts	1 year from date of manufacture**
*Products certified to California CP-201 and/or CP-206 Standards have been factory tested and met all applicable performance standards and specifications and will have an OPW registration card enclosed/attached to the product.	

OPW's exclusive obligation under this limited warranty is, at its option, to repair, replace or issue credit (in an amount not to exceed the list price for the product) for future orders for any product that may prove defective within the applicable warranty period. (Parts repaired or replaced under warranty are subject to prorated warranty coverage for remainder of the original warranty period). Complete and proper warranty claim documentation and proof of purchase required. All warranty claims must be made in writing and delivered during the applicable warranty period to OPW at OPW 9393 Princeton-Glendale Road Hamilton, Ohio, USA 45011, Attention: Customer Service Manager. No products may be returned to OPW without its prior written authority.

This limited warranty shall not apply to any FlexWorks or VAPORSAVER™ product unless it is installed by an OPW attested installer and all required site and warranty registration forms are completed and received by OPW within 60 days of installation. This limited warranty also shall not apply to any FlexWorks, VAPORSAVER™ or other OPW product: unless all piping connections are installed with a nationally-recognized or state-approved leak detection device in each tank and dispenser sump (which are not for storage and from which all discharge hydrocarbons must be removed, and the systems completely cleaned, within 24 hours); unless testable sumps utilize FlexWorks pipe and access fittings; unless a sump inspection log or an EPA recommended/required checklist is maintained and the results are furnished to OPW upon request; and unless OPW is notified within 24 hours of any known or suspected product failure and is provided with unrestricted access to the product and the site. This limited warranty also shall not apply to any product which has been altered in any way, which has been repaired by anyone other than a service representative authorized by OPW, or when failure or defect is due to: improper installation or maintenance (including, without limitation, failure to follow FlexWorks Quick Reference Manual Installation Guide and all product warning labels); abuse or misuse; violation of health or safety requirements; use of another manufacturer's, or otherwise un-



authorized, substances or components; soil or other surface or subsurface conditions; or fire, flood, storm, lightning, earthquake, accident or any other conditions, events or circumstances beyond OPW's control.

THIS LIMITED WARRANTY IS IN LIEU OF ALL OTHER WARRANTIES, EXPRESS OR IMPLIED, AND ALL OTHER WARRANTIES INCLUDING, WITHOUT LIMITATION, THE WARRANTIES OF MERCHANTABILITY AND FITNESS FOR A PARTICULAR PURPOSE, ARE HEREBY EXCLUDED.

OPW shall have no other liability whatsoever, whether based on breach of contract, negligence, gross negligence, strict liability or any other claim, including, without limitation, for special, incidental, consequential or exemplary damages or for the cost of labor, freight, excavation, clean-up, downtime, removal, reinstallation, loss of profit, or any other cost or charges. No person or entity is authorized to assume on behalf of OPW any liability beyond this limited warranty. This limited warranty is not assignable.

**\*\* Date of manufacture on this product is located on the flat area of the valve body, under float.**

## GENERAL INSTRUCTIONS

The OPW 7150 Overfill Prevention Valve is designed for tight fill, gravity drop applications to help prevent accidental or intentional overfilling of underground storage tanks. It is installed in the UST drop tube in place of a standard drop tube.

The main 7150 valve closes when liquid reaches the initial shut off point. A small bypass valve remains open to allow the delivery hose to drain at 3-5 gallons per minute. If the delivery truck valve is not closed after initial shut-off, the bypass valve will close and will restrict all fuel delivery to ensure that the top of the tank is not wetted per EPA requirements.

The 7150 models of the 7150 are designed to be installed with the following OPW products: Face Seal Adaptor, OPW Spill Container or Multi-port, Jack Screw Kit, Rotatable Product Adaptor, and Product Cap.

### **IMPORTANT**

Read these assembly and installation instructions completely and carefully prior to starting. Check to make sure all parts have been provided. Use only the parts supplied; substitution of parts may cause product failure.

Failure to follow instructions may cause improper product operation or premature failure which may permit storage tank overfill. An overfilled storage tank may create hazardous conditions and/or environmental contamination.

### **CAUTION**

**Do not remove elastic band from around float until instructed to do so, as damage to valve may result.**

### **WARNING**

**Failure to properly connect delivery hose and elbow, and/or disconnecting a liquid filled delivery hose or elbow will result in a hazardous spill, which may result in personal injury, property damage, fire, explosion, and water and soil pollution.**

- Make sure all connections, including the hose and elbow connections, between storage tank and transport are securely coupled.
- Make sure the lip seal and/or all gaskets in the delivery elbow are properly in place to prevent spills.
- Do not operate with damaged or missing parts, which prevent tight connections.

**Normal Operation:** A Hose "Kick" and reduced flow signal that the tank is full. Close transport delivery valve and drain hose into tank before disconnecting any hose fitting.

**Overfilled Tank:** Failure of the hose to drain after closing the delivery valve signals an overfilled tank. Do Not Disconnect any delivery hose fitting until the liquid level in the tank has been lowered to allow the hose to drain into the tank.

### **WARNING**

**In the event you are splashed with fuel remove wet clothing immediately. Skin contact with gasoline can cause chemical burns and may result in inhalation of vapors that may be fatal. Never go inside confined areas after being splashed and never go near ignition sources.**

### **IMPORTANT**

Determine if the underground storage tank is equipped with a ball float vent valve, as illustrated in Figure 24. In all systems, the shut-off point of the 7150 must be reached before the ball float reduces flow to ensure proper overfill valve operation.

### **TOOLS NEEDED FOR INSTALLATION AND ASSEMBLY:**

1. 7150-TOOL or 7150-TOOLC or 7150-TOOLCT (includes the following)
  - Sharp 3/16" drill bit with stop
  - Punch

**NOTE: Testable 7150 models ending with a "T" require the 7150-TOOLCT or modified 7150-TOOL or 7150-TOOLC**

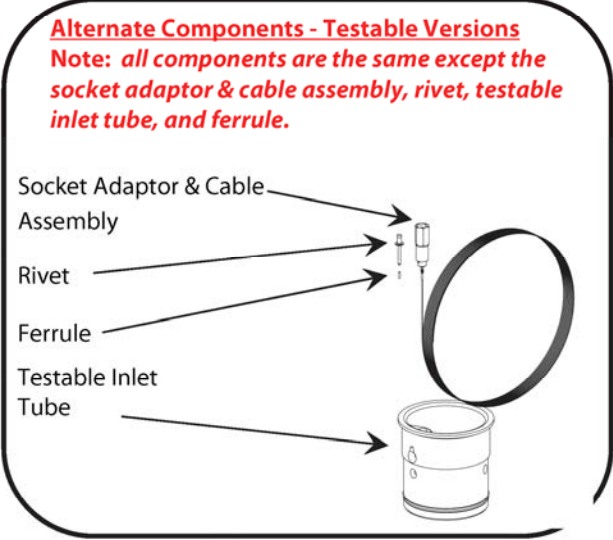
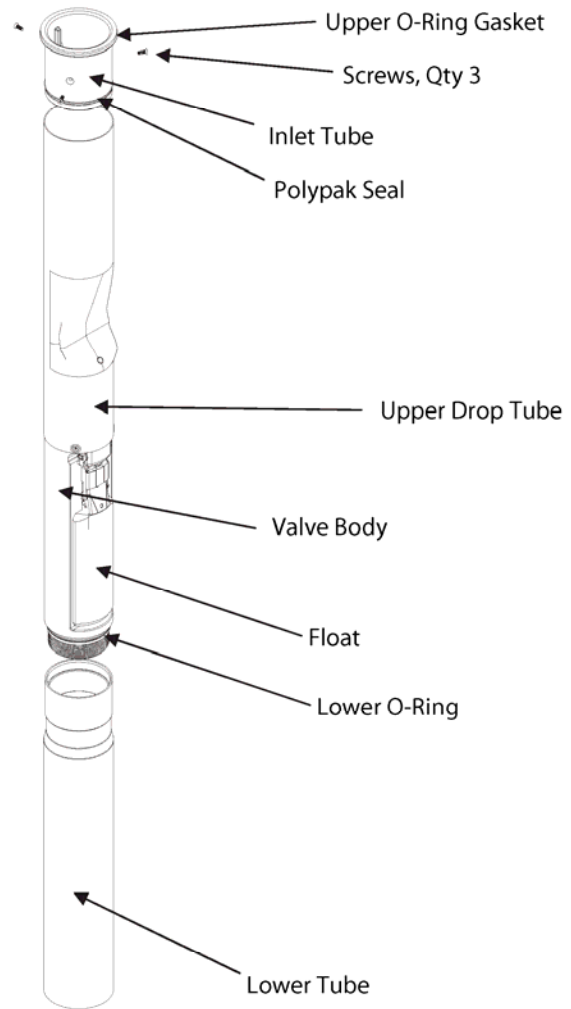
2. Drill
3. Hammer
4. Tape measure
5. Hacksaw or cut-off saw, fine tooth; 24 teeth/inch
6. Fine half round file
7. Screwdriver - Phillips blade
8. Fine grit sandpaper / steel wool
9. Grease, black moly
10. Torque Wrench
11. Band clamp (3-3/4" diameter minimum)
12. **TESTABLE MODELS ONLY:** rivet tool for 1/8" mandrel, crimping tool / pliers, wire cutter / scissors, pipe dope, 1/4" square drive extension or 3/8" square drive extension with 3/8" to 1/4" socket adapter.

**WARNING**

**Using electrically operated equipment near gasoline or gasoline vapors may result in fire or explosion, causing personal injury and property damage. Check to assure the working area is free from such hazards, and always use proper precautions.**

**IMPORTANT:** The figures in this installation and maintenance instruction may contain vapor recovery equipment (including model numbers) that is not certified by the California Air Resources Board (CARB) for a specific Phase I Vapor Recovery System. Please refer to Exhibit 1 of the appropriate CARB Phase I Executive Order for a list of certified Phase I Vapor Recovery System Equipment.

**7150 Parts Diagram**



**IMPORTANT:** The instructions below for the 71SO Overfill Prevention Valve are written for the initial stage shutoff at 95%, but can be adjusted to shutoff at any desired tank capacity. Please contact the Authority Having Jurisdiction (AHJ) and review local, state, and national codes to determine the regulatory requirements governing shut-off capacity in your region, as well as take into account other considerations such as extreme tank tilt. In all cases, the upper tube must protrude into the tank at least 6 1/2" to ensure that the valve can shut off flow into the tank completely before the top of the tank is wetted as per EPA requirements.

**HOW TO LOCATE THE POSITION OF THE 71SO AT 95% TANK CAPACITY**  
*(Shut-off points can be adjusted to any capacity to comply with AHJ Requirements)*

The length of the upper tube and the placement of the 71SO valve body determine the shut-off point. Following the standard instructions for the OPW 71SO will provide for initial shutoff at 95%. In all cases, the upper tube length must be a minimum of 6-1/2" plus the length of the riser pipe. All length measurements are in inches.

**INSTRUCTIONS**

- 1) Find tank capacity (in gallons) from tank calibration chart provided by tank manufacturer.
- 2) Calculate 95% of capacity
- 3) Locate the 95% volume number on the tank calibration chart.
- 4) Find the dipstick number (X) which corresponds to the 95% tank volume. And, find the dipstick number (Y) which corresponds to the 100% volume.
- 5) Subtract the dipstick number (X) from the tank diameter (Y) to find the upper tube reference number (Z).

$$(Y) - (X) = (Z)$$

- 6) Subtract 2" from (Z) to find the upper tube depth (C).

$$(Z) - 2" = C$$

- 7) Is C less than 6-1/2"?

**NO** Upper tube length is C plus the distance from the top of the Face Seal Adaptor installed on the riser pipe to the inside, top lip of the storage tank (A).

$$\text{Upper Tube Length} = C + (A)$$

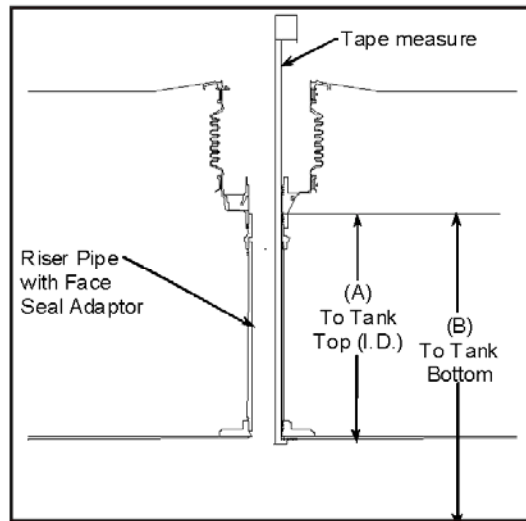
**For testable models only, ending in "T":**  
**Upper Tube Length = C + (A) - 1-1/2"**

**YES** Upper tube length is 6-1/2" plus the riser pipe measurement (A).

$$\text{Upper Tube Length} = 6-1/2" + (A)$$

**For testable models only, ending in "T":**  
**Upper Tube Length = 6-1/2" + (A) - 1-1/2"**

**NOTE:** You must find the actual tank capacity number that correlates to the 6-1/2" + (A) depth for the station records. This number may also be used for the purposes of calibrating an electronic tank level system.



**Figure 1**

**EXAMPLE**

- 1) For an Owens-Corning Model G-3 Fiberglass® Tank Calibration Chart:  
 Tank Capacity - 10,000 gal., nominal 9,403 gal.  
**NOTE: Use actual capacity only**

- 2) 95% of actual tank capacity = 0.95 x 9403 gal. = 8933 gal.
- 3) The closest number which is less than 8933 gal. Is 8910 gal. Choosing the closest number less than 95% of actual capacity ensures that the initial shutoff will occur when the tank is no more than 95% full.
- 4) The calibration chart reading of 8910 gal. corresponds to a dipstick measurement of 82".

- 5) Dipstick number (X) = 82"  
 Tank diameter (Y) = 92"  
 $(Y) - (X) = (Z)$        $(92" - 2" = 10")$   
 $(Z) = 10"$
- 6)  $(Z) - 2" = C$        $(10" - 2" = 8")$   
 $C = 8"$
- 7) Is 8" less than 6-1/2"?

**NO** Measure the distance from the top of the FSA-400 Face Seal Adaptor installed on the riser pipe to the inside, top lip of the storage tank and obtain measurement (A).

Upper tube length = C + (A)

**For testable models only, ending in "T": Upper Tube Length = C + (A) - 1-1/2"**

**ASSEMBLY INSTRUCTIONS**

**IMPORTANT:** Each of the numbered steps in the installation instructions are designed as a CHECK LIST to ensure proper installation and trouble free operation of the OPW 71SO Overfill Prevention Valve.

Read and follow these steps carefully, checking them off as you proceed.

Figure numbers correspond to step numbers for easy reference.

**STEP 1: MEASURE**

Install the OPW Face Seal Adaptor and the OPW Thread-on Spill Container on the Fill Riser (Refer to the Installation Instructions Supplied with the Spill Container). Insert a tape measure through the riser pipe and hook it under the inside of the tank in the lengthwise direction. Measure the distance from the top of the Face Seal Adaptor threads inside the base of the spill container bucket just below the drain valve outlet window to the inside, top lip of the storage tank (Dim. "A") (See Figure 1 & 1A).

The top flange on the 71SO will rest on the Face Seal Adaptor just below the drain valve outlet, and be locked in place between the Face Seal Adaptor and the 4" nipple that is installed in the spill container with the Jack Screw Kit (See Figure 1A). (For riser pipe configurations other than that shown, consult installation drawings or use other necessary means to measure Dimension "A").

Using a tape measure, measure the distance from the

top of the Face Seal Adaptor in the spill container to the bottom of the tank (Dim. "B").

**IMPORTANT:** Inspect the riser pipe for any foreign material. Over spray from tank relining or any internal burrs inside of pipe must be removed prior to installation. Failure to have an unobstructed riser pipe may prevent proper installation and operation of the valve. The 71SO is designed for installation into schedule 40 riser pipes. The 71SO cannot be installed into schedule 80 riser pipes.

**STEP 2: MARK THE TUBE**

Use the result from Step 1 and **HOW TO LOCATE THE POSITION OF THE 71SO AT 95% TANK CAPACITY** to mark the upper tube. Measure the distance from the seam where the upper tube and valve body meet. Use a tape measure to mark the calculated upper tube length onto the upper tube. See Figure 2.

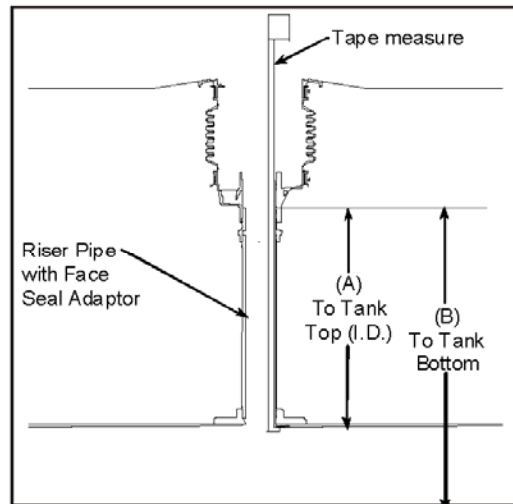


Figure 1

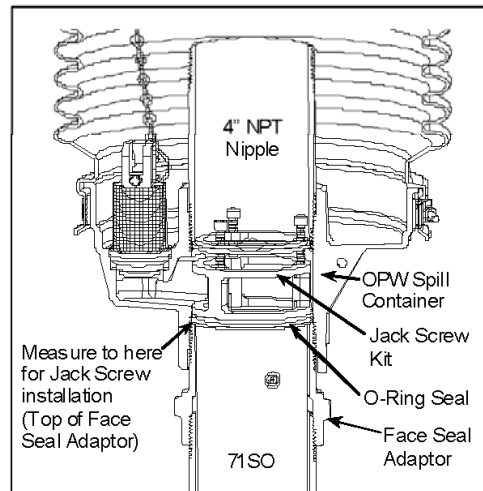


Figure 1A

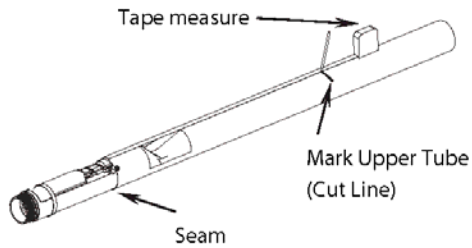


Figure 2

**STEP 3: CUT THE UPPER DROP TUBE**

Attach the supplied band clamp to the upper tube just below the mark and ensure that it is assembled square to the tube. The clamp can be used as a guide for making a square cut. If a vise is used, clamp on the valve body casting only to avoid damage to the float and tubes (See Figure 3A). Carefully saw through the tube squarely, at the mark made in Step 2. Use a hacksaw with a new fine-tooth blade. Rotating the upper tube as the sawing progresses will minimize run out and ensure a square 90-degree cut. Remove the band clamp after tube is cut.

**CAUTION - DO NOT use a pipe or tubing cutter to cut the upper drop tube, this may damage the tube, causing it to be out of round thereby prohibiting assembly of the unit.**

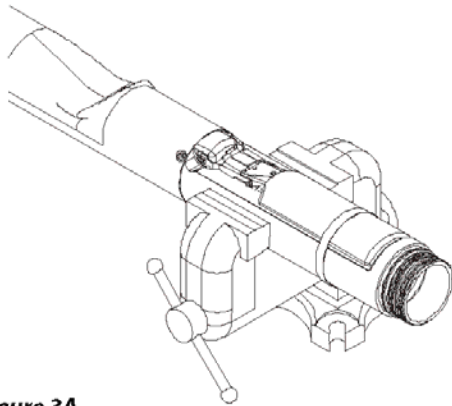


Figure 3A

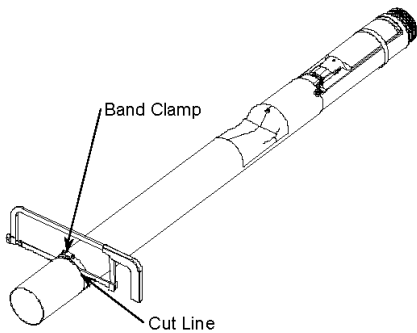


Figure 3B

**IMPORTANT:** Remove all chips and shavings generated in steps 3 thru 5 out of the cut end of the tube. **DO NOT** remove chips and shavings by dumping thru valve body.

**STEP 4: FILE THE UPPER DROP TUBE**

File the upper tube square, and remove any burrs or rough edges. Make sure the cut is flat and square.

**IMPORTANT:** Carefully file a good chamfer on the inside edge of the drop tube to provide a lead-in for the polypak seal and inlet tube installed in Step 8.

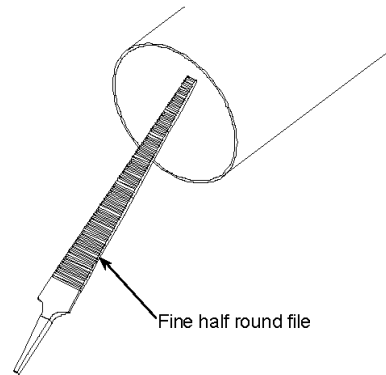


Figure 4

**STEP 5: SAND THE UPPER DROP TUBE**

Sand the inside of the drop tube with sandpaper and/or steel wool to remove all burrs and sharp edges. After sanding wipe down the inside of the tube with a clean rag from the top to approximately 4 inches down to remove any debris.

**Caution:** Failure to properly chamfer, sand, and clean the drop tube may cut the seal and result in a failure of a pressure decay leak test.

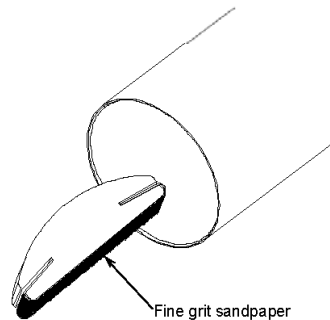
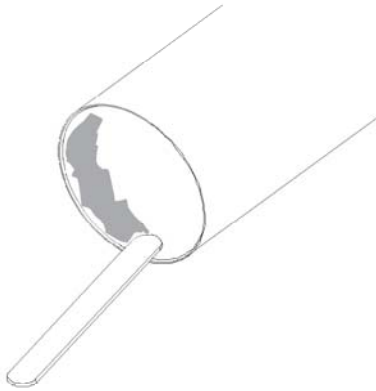


Figure 5

**STEP 6: APPLY GREASE TO DROP TUBE**

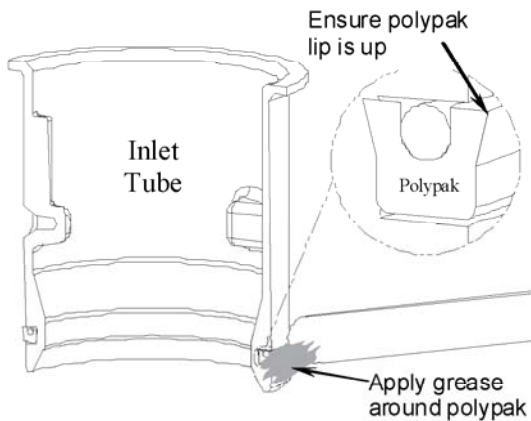
Apply black moly grease to the inside diameter of the upper drop tube. Make sure coverage is completely around the tube as shown in **Figure 6**.



**Figure 6**

**STEP 7: APPLY GREASE TO POLYPAK SEAL**

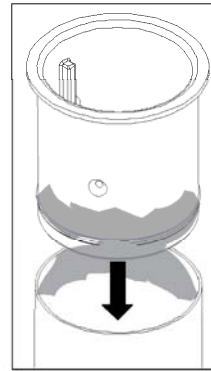
Ensure that the polypak seal is installed on the inlet tube with the lip up as shown in **Figure 7**. Apply black moly grease to the polypak as shown. Make sure coverage is completely around the polypak seal.



**Figure 7**

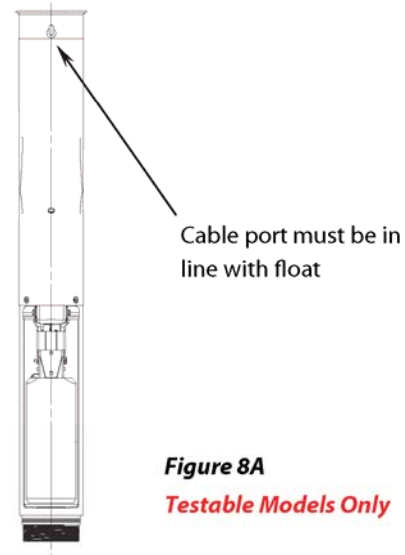
**STEP 8: INSTALL INLET TUBE**

Insert the inlet tube into the upper tube until the upper tube seats against the flange on the inlet tube. Ensure polypak is inserted evenly and stays in inlet tube groove.



**Figure 8**

**NOTE: Testable inlet tube must have cable port in line with float. Testable inlet tube bottoms out on stop, it does not bottom out on inlet flange. See Figure 8A**



**Figure 8A**  
*Testable Models Only*

**SEE PAGE 8 FOR INSTRUCTIONS USING THE 7150-TOOL.**

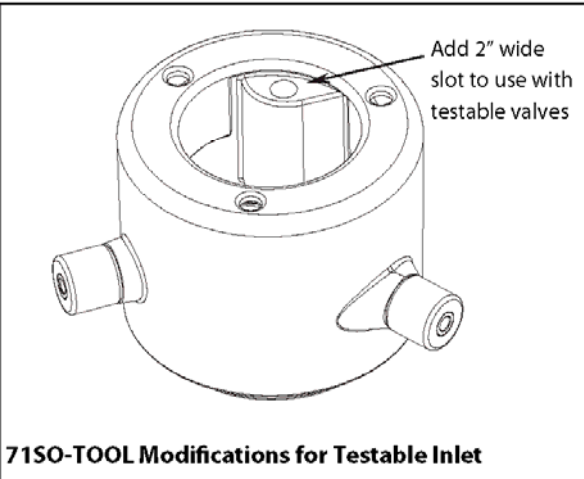
**SEE PAGE 9 FOR INSTRUCTIONS USING THE 7150-TOOLC.**

**SEE PAGE 10 FOR INSTRUCTIONS USING THE 7150-TOOLCT.**

*Note: testable 7150 models ending with a "T" require the 7150-TOOLCT or modified 7150-TOOL or 7150-TOOLC*

**71SO-TOOL PROCEDURE BELOW,  
FOR 71SO-TOOLC, SEE PAGE 9  
FOR 71SO-TOOLCT, SEE PAGE 10**

**Note: 71SO-TOOL can only be used with testable  
overflow valves if modified as shown below. A 2"  
wide slot must be added to accommodate cast lug.**



**STEP 9A: INSERT 71SO-TOOL OVER INLET TUBE**  
To install the 71SO-TOOL (sold separately) over the inlet tube, first loosen all three knobs, so the tool can pass freely over the inlet tube flange. Align the slot on the tool with the key on the inlet tube and insert the tool down. See Figure 9A.

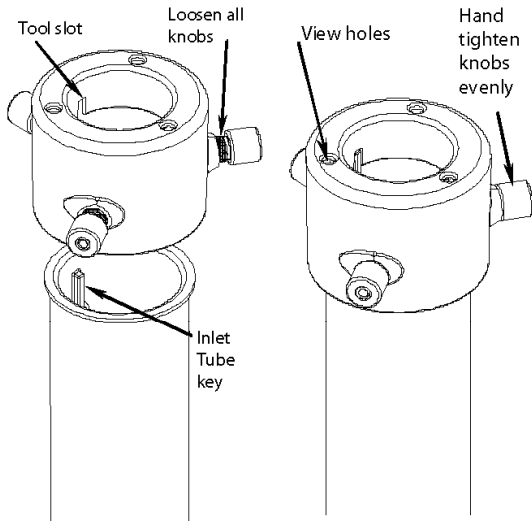


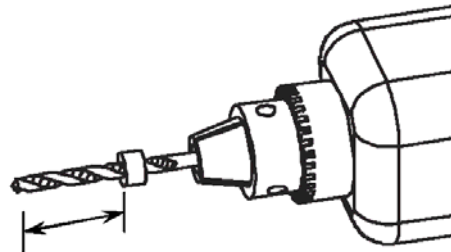
Figure 9A

Figure 10A

**STEP 10A: TIGHTEN THE 71SO-TOOL**  
Use the three view holes to ensure that the tool seats out flat against the top of the inlet tube. To prevent vertical movement of the tool during drilling, hand tighten all three knobs evenly to the upper drop tube. See Figure 10A.

**STEP 11A: PREPARE DRILL AND BIT**  
Confirm that the stop on the 3/16" drill bit supplied with the 71SO-TOOL is in the correct position before drilling. The stop is factory installed at a distance between 2" to 2-1/16" from the tip with the 71SO-TOOL. If the stop is not at the correct position it must be fixed before drilling.

**CAUTION: If the drill stop is not in the proper location failure of a pressure decay leak test may result.**



Tip to stop dimension must be 2" to 2-1/16".

Figure 11A

**STEP 12A: DRILL HOLES**  
With the inlet tube and 71SO-TOOL in place, carefully drill a 3/16" diameter hole in the upper tube using the drill bushing in the knob as a guide. The drill stop is positioned so it will bottom out against the knob after the bit has drilled through the upper drop tube. If the stop is positioned wrong either no hole will be drilled, or a through hole could potentially be drilled through the inlet tube. If no hole is drilled return to step 11A and check the stop dimension. If a hole is drilled through the inlet tube or into the screw hole the assembly is not salvageable. Drill (2) more holes in the two remaining knobs.

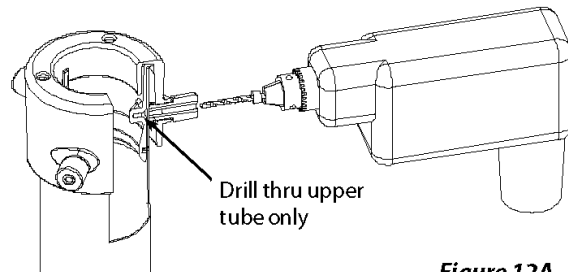
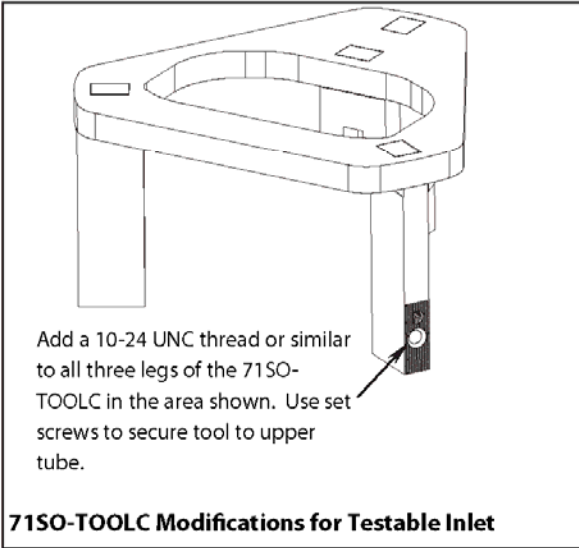


Figure 12A

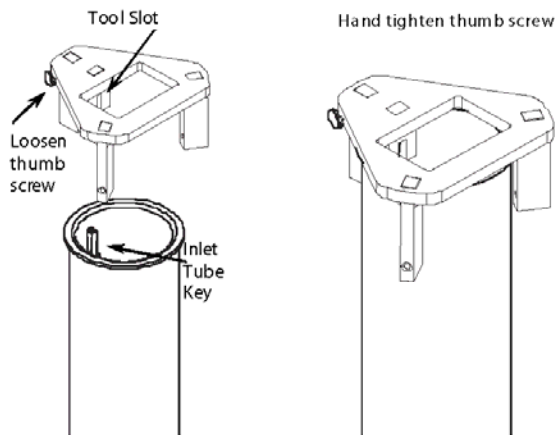
**71SO-TOOLC PROCEDURE BELOW,  
FOR 71SO-TOOL, SEE PAGE 8  
FOR 71SO-TOOLCT, SEE PAGE 10**

**Note: 71SO-TOOLC can only be used with testable  
overflow valves if modified as shown below.**



**STEP 9B: INSERT 71SO-TOOLC OVER INLET TUBE**

To install the 71SO-TOOLC (sold separately) over the inlet tube, first loosen the thumb screw, so the tool can pass freely over the inlet tube flange. Align the slot on the tool with the key on the inlet tube and insert the tool down. **See Figure 9B.**



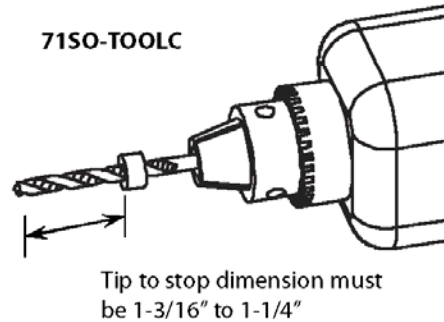
**STEP 10B: TIGHTEN THE 71SO-TOOLC**

Ensure that the tool seats flat against the top of the inlet tube. To prevent vertical movement of the tool during drilling, hand tighten the thumb screw against the upper drop tube. **See Figure 10B.**

**STEP 11B: PREPARE DRILL AND BIT**

Confirm that the stop on the 3/16" drill bit supplied with the 71SO-TOOLC is in the correct position before drilling. The stop is factory installed at a distance between 1-3/16" to 1-1/4" from the tip with the 71SO-TOOLC. If the stop is not at the correct position it must be fixed before drilling.

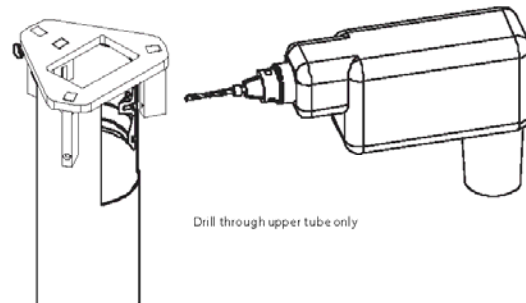
**CAUTION: If the drill stop is not in the proper location failure of a pressure decay leak test may result.**



**Figure 11B**

**STEP 12B: DRILL HOLES**

With the inlet tube and 71SO-TOOLC in place, carefully drill a 3/16" diameter hole in the upper tube using the hole in the 71SO-TOOLC as a guide. The drill stop is positioned so it will bottom out against the tool after the bit has drilled through the upper drop tube. If the stop is positioned wrong either no hole will be drilled, or a through hole could potentially be drilled through the inlet tube. If no hole is drilled return to step 11B and check the stop dimension. If a hole is drilled through the inlet tube or into the screw hole the assembly is not salvageable. Drill (2) more holes in the two remaining guide holes.



**Figure 12B**



**71SO-TOOLCT PROCEDURE BELOW,  
FOR 71SO-TOOL, SEE PAGE 8  
FOR 71SO-TOOLC, SEE PAGE 9**

**STEP 9C: INSERT 71SO-TOOLCT OVER INLET TUBE**  
To install the 71SO-TOOLCT (sold separately) over the inlet tube, first loosen the thumb screws, so the tool can pass freely over the inlet tube flange. Align the slot on the tool with the key on the inlet tube and insert the tool down. See Figure 9C.

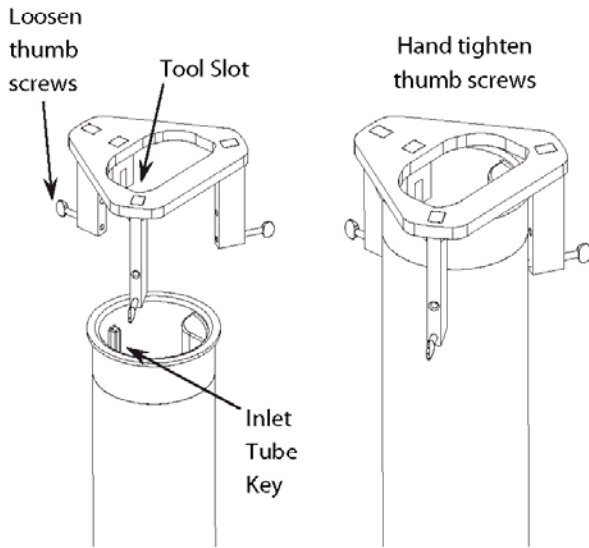


Figure 9C

Figure 10C

**STEP 10C: TIGHTEN THE 71SO-TOOLCT**  
Ensure that the tool seats flat against the top of the inlet tube. To prevent vertical movement of the tool during drilling, hand tighten the thumb screws against the upper drop tube. See Figure 10C.

**STEP 11C: PREPARE DRILL AND BIT**  
Confirm that the stop on the 3/16" drill bit supplied with the 71SO-TOOLCT is in the correct position before drilling. The stop is factory installed at a distance between 1-3/16" to 1-1/4" from the tip with the 71SO-TOOLCT. If the stop is not at the correct position it must be fixed before drilling.

**CAUTION: If the drill stop is not in the proper location failure of a pressure decay leak test may result.**

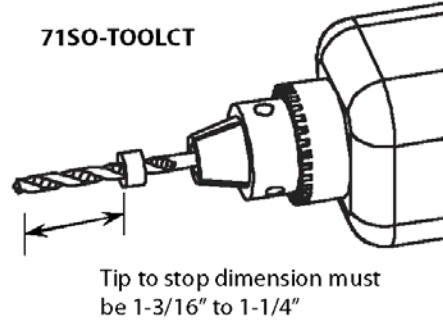


Figure 11C

**STEP 12C: DRILL HOLES**  
With the inlet tube and 71SO-TOOLCT in place, carefully drill a 3/16" diameter hole in the upper tube using the hole in the 71SO-TOOLCT as a guide. The drill stop is positioned so it will bottom out against the tool after the bit has drilled through the upper drop tube. If the stop is positioned wrong either no hole will be drilled, or a through hole could potentially be drilled through the inlet tube. If no hole is drilled return to step 11C and check the stop dimension. If a hole is drilled through the inlet tube or into the screw hole the assembly is not salvageable. Drill (2) more holes in the two remaining guide holes.

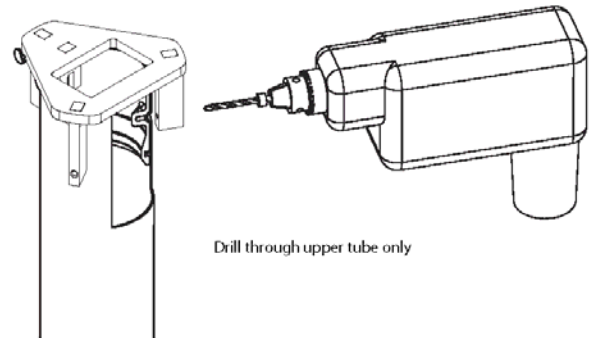


Figure 12C

**STEP 13: DIMPLE FIRST HOLE**

Remove tool. Remove any chips or burrs from the drilling operation. Place the assembly on a solid surface. Using the punch supplied with the 7150-TOOL, 7150-TOOLC, and 7150-TOOLCT, align the tip of the punch with the drilled hole and dimple the upper drop tube by striking the punch with a hammer until the drop tube is formed into countersunk hole in the inlet tube. After punching, remove any chips that may have fallen into the inlet tube screw hole.

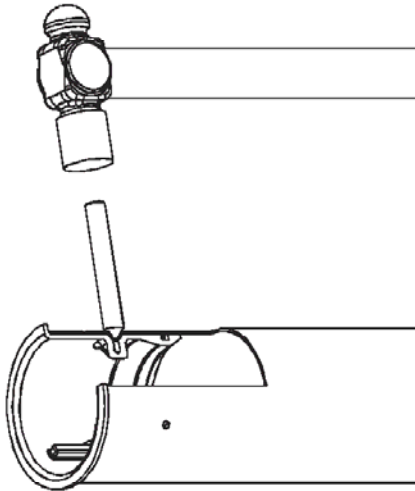


Figure 13

**STEP 14: ASSEMBLE FIRST SCREW**

Ensure that the drop tube was formed into the countersunk screw hole as shown in Figure 14 if not return to Step 13. Apply black moly grease to screw and tighten first screw into inlet tube with a screwdriver. Use only the taptite screws that are supplied with the unit. Seating torque is 20 in-lbs min. to 35 in-lbs max. Screw head should be flush with the drop tube. Do not over tighten.

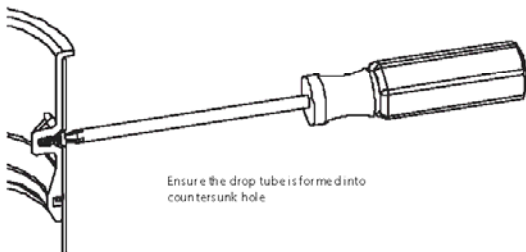


Figure 14

**STEP 15: DIMPLE REMAINING HOLES**

Remove any chips or burrs from the drilling operation. Dimple the next (2) holes as done in Step 13. Make sure the assembly is on a solid surface when punching. After punching, remove any chips that may have fallen into the inlet tube screw hole.

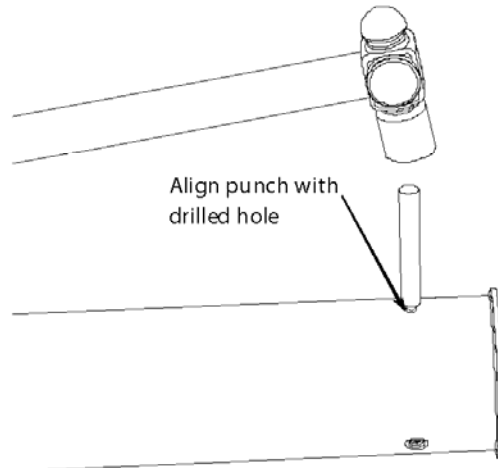


Figure 15

**STEP 16: ASSEMBLE OTHER SCREWS**

Apply black moly grease to screws and tighten the other (2) screws into inlet tube with a screwdriver as done in Step 14. Use only the taptite screws that are supplied with the unit. Seating torque is 20 in-lbs min. to 35 in-lbs max. Do not over tighten.

**STEP 17: APPLY GREASE TO LOWER O-RING AND BODY THREADS**

Apply black moly grease to the lower tube o-ring and body threads as shown. Make sure coverage is completely around the o-ring. Install o-ring in groove just above threads.

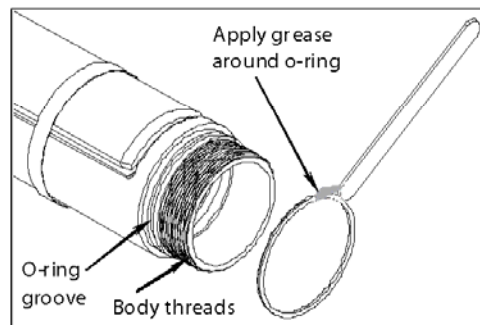


Figure 17

**STEP 18: LOWER TUBE ASSEMBLY**

If a vise is used, clamp on the valve body casting only to avoid damage to the float and tubes. Thread the lower tube onto the valve body until the lower tube bottoms out on valve body. Tube can be tightened by hand or with a strap wrench. If a strap wrench is used try to position it on the threaded insert portion of the lower tube to prevent damaging the tube.

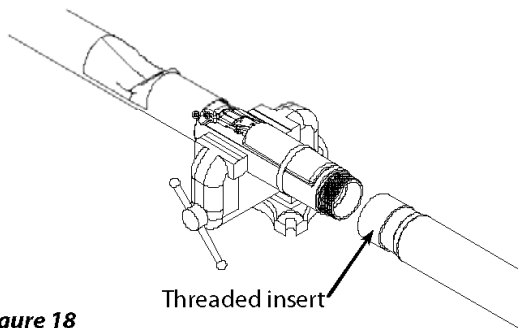


Figure 18

**NOTE:** Before installing the valve in the tank, a pressure test can be performed on the valve to check for vapor tightness. Seal off both ends of the tube with inflatable plumber's plugs. Apply a maximum 10" W.C. (1/3 PSI) air pressure. If pressure does not hold and a leak can be located with soap solution, do not install the valve. Send the valve back to OPW for warranty evaluation.

**CAUTION:** Do not over-pressurize. Excess pressure can damage the valve.

**STEP 19: CUT LOWER TUBE**

Measuring from the underside of the inlet tube flange, mark the overall length of the drop tube a distance of (B) minus 6". Determine dimension (B) from the measurements taken in Step 1, Figure 1 (Top of the Face Seal Adapter below the drain valve outlet in the spill container to the bottom of the tank). Saw off the excess tube at a 45-degree angle or per local codes or requirements and file off any sharp burrs (Refer to Figure 24). **Optional:** Install the OPW Tank Bottom Protector on the lower tube (Refer to Installation instructions supplied with the Tank Bottom Protector).

**IMPORTANT:** Remove all chips and shavings out of the cut end of the tube. DO NOT remove chips and shavings by dumping thru valve body.

**FOR STANDARD VAPOR TIGHT MODELS, PROCEED TO STEP 20 ON PAGE 14.**

**FOR TESTABLE MODELS, PROCEED TO PAGE 13.**

**TESTABLE PROCEDURE ONLY, FOR STANDARD MODELS, PROCEED TO NEXT PAGE.**

**STEP 1T: INSTALL SOCKET ADAPTOR ASSY**

Put cable thru threads in inlet tube and out thru cable port on side of inlet tube. Thread the socket adaptor assembly finger tight into the inlet tube. Note: the cable port on the inlet tube must be in line with the float as shown previously in Figure 8A.

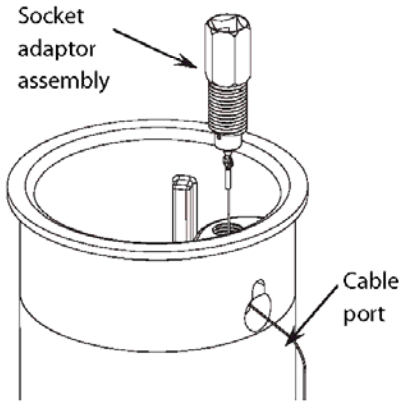


Figure 1T

**STEP 2T: PASS CABLE THRU FERRULE**

Pass cable thru ferrule. Loop cable and then pass cable back thru ferrule. Keep ferrule loose until cable length is determined in the next step. Note: if cable end frays it may be necessary to trim the cable again to pass thru ferrule.

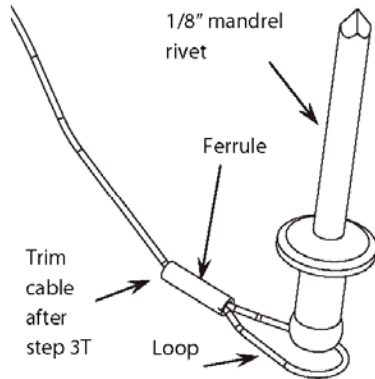


Figure 2T

**STEP 3T: DETERMINE CABLE LENGTH**

Run cable along upper tube and over the top plate on the float bracket as shown. With the float in the down position (as shown in Figure 3T) align loop in cable with rivet and top hole in float bracket. Use the rivet as a template to size the loop in the cable and pull cable tight and crimp ferrule with crimping tool / pliers onto cable at this location. Trim excess cable with wire cutter / scissors. For reference, from the seam where the upper tube and valve body meet to the end of the cable after trimming will require approximately 3.5" of cable.

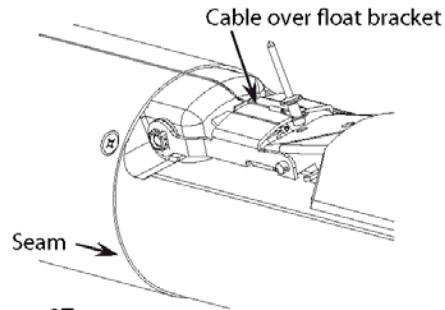


Figure 3T

**STEP 4T: ATTACH CABLE TO FLOAT BRACKET**

Ensure cable is over the float bracket. Using the supplied rivet align loop in cable with top hole in float bracket and pass rivet thru cable loop and float bracket hole. Using rivet tool for 1/8" dia mandrel attach rivet and cable to the float bracket. See last page for list of replacement cable parts.

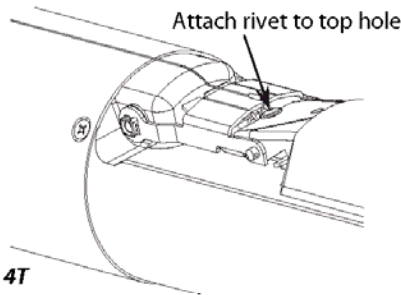


Figure 4T

**STEP 5T: ENSURE PROPER CABLE OPERATION**

Unthread the socket adaptor assembly from the inlet tube and ensure float and poppet move freely when socket adaptor assembly is pulled on. It should only require 3" to 4" of movement in order to actuate the float and poppet. Thread socket adaptor assembly finger tight into inlet tube after testing.

**STEP 20: PREPARE FILL RISER FOR VALVE INSERTION**

**IMPORTANT:** Inspect the riser pipe for any foreign material. Over spray from tank relining or any internal burrs inside of pipe must be removed prior to installation. Failure to have an unobstructed riser pipe may prevent proper installation or operation of the valve. Thoroughly clean top of riser pipe.

**STEP 21: REMOVE ELASTIC BAND**

Remove the elastic band securing the float to the valve body. The float will move into an outward position.

**STEP 22: INSERT DROP TUBE**

Make sure the upper O-Ring gasket is under the flange of the inlet tube. Hold the float down against the valve body and slowly insert the drop tube overfill valve into the riser pipe. Do not force valve into the riser pipe. If any obstruction or foreign matter interferes with smooth insertion of the valve, the riser pipe must be cleared.

**WARNING**

**Failure to follow the assembly and installation instructions or use of excessive force to insert the OPW 7150 will VOID THE WARRANTY.**

Difficulty in removing the existing fill tube (if there is one) means there may be an obstruction in the riser pipe. Look for burrs, deformations, excess tank lining material or other projections that may interfere with easy insertion of the OPW 7150. The 7150 is designed for insertion into schedule 40 pipe. If schedule 80 pipe has been used for the riser, the 7150 cannot be installed. If seamed pipe has been used, the internal weld bead may interfere with the OPW 7150 and prevent installation. If the OPW 7150 won't slip in easily DON'T FORCE IT! Damage to the valve may result if excess force is used. Examine the riser pipe carefully; determine the nature of the obstruction; take appropriate steps to remove it.

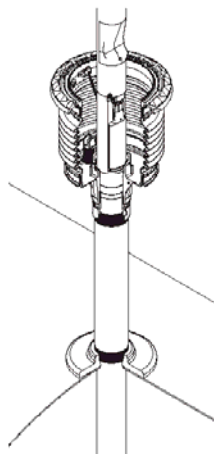


Figure 22

**STEP 23: CHECK INSTALLATION**

Insert the drop tube all the way into the tank until the flange and gasket seat onto the top of the Face Seal Adaptor. The float will swing out into the operating position as it passes into the tank.

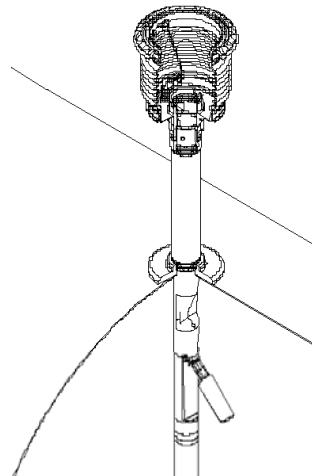


Figure 23

Make sure that the float is aligned along the length of the tank. The length of the tank can easily be determined by locating other manholes or pump boxes that are installed around other tank fittings. Look into the drop tube and align the deflector with the length of the tank.

**For testable models only:** Unthread the socket adaptor assembly from the inlet tube (a 3/8" square drive extension will attach to the socket adaptor, secure all tools to ensure they don't fall into the tank or valve) and ensure float and poppet move freely when socket adaptor assembly is pulled on. When looking down into the upper tube ensure poppet is visible when socket adaptor is pulled and resets properly when socket adaptor is released. See page 17 for full testing details. If poppet does not actuate freely take appropriate steps to correct before proceeding.

**CAUTION: No obstruction in the tank can be within 14" from the center of the riser pipe or the valve may not operate properly (See Figure 24).**

**STEP 24: ALIGN VALVE**

Install the OPW Jack Screw Kit and a 4" NPT nipple to lock the valve in place. Refer to the Installation Instructions supplied with the Jack Screw Kit. **For testable models ensure that the socket adaptor is aligned so it does not interfere with the jack screw kit.** (see Figure 24A). Install the Rotatable Product Adaptor (Refer to Installation Instructions supplied with the Product Adaptor.) Make sure that the valve does not rotate while tightening the adaptor by observing the position of the deflector. **The valve must remain aligned along the length of the tank as in Step 23.** Repeat this step as necessary to assure proper valve alignment.

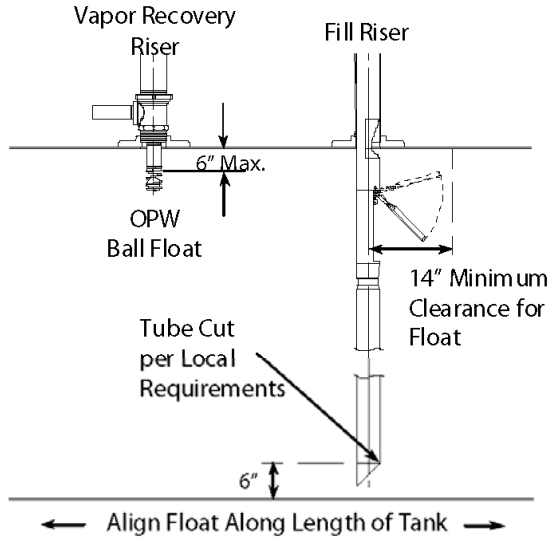


Figure 24

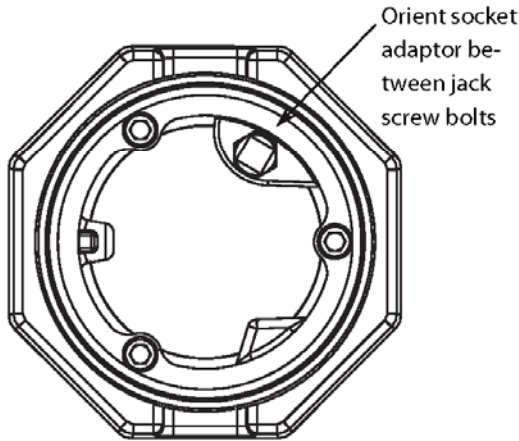
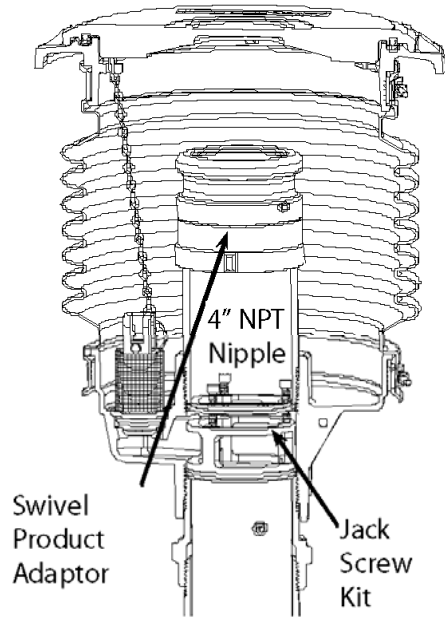


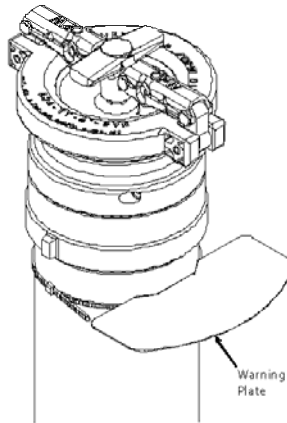
Figure 24A

**FOR TESTABLE MODELS ONLY:** Check installation again as done in Step 23 to ensure poppet actuates and resets properly. See page 17 for full testing details. Apply pipe dope to the socket adaptor threads. Pipe dope should be a non-hardening gasoline resistant pipe thread seal compound. Install socket adaptor and torque to 3.5 ft-lbs (42 in-lbs) minimum to 5.0 ft-lbs (60 in-lbs) maximum. After installing socket adaptor where required, pressure test testable overfill valve per CARB TP201.1D to ensure valve is vapor tight.

**STEP 25: INSTALL WARNING PLATE**

Bend the three warning plate ears down then slide the tie wrap over the warning plate ears and position warning plate against riser pipe approximately 1" below the adaptor. Tighten the tie wrap securely. The valve is now fully installed and in operating position.

**NOTE: the warning plate includes important warnings, operating parameters, and listing information and must be installed.**



**Figure 25**

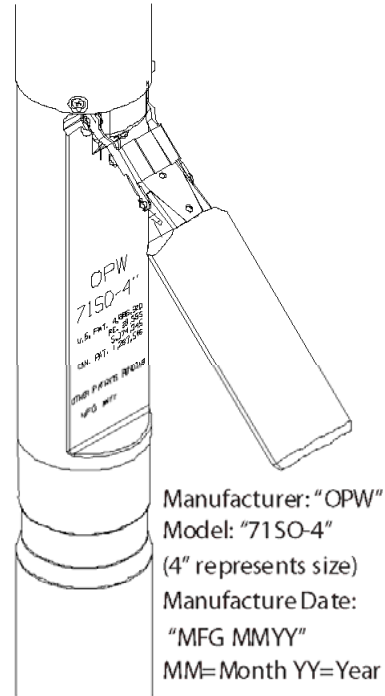
**STEP 26: VALVE REMOVAL**

The valve can be removed for tank leak testing, inspection, etc., by removing the Rotatable Product Adaptor, the 4" nipple, and the Jack Screw Kit. Reinstall per the above instructions.

**For testable models only:** It is not necessary to remove the valve to check poppet movement / function. See Page 17 for full testing details.

**STEP 27: ELECTRONIC LIQUID LEVEL MONITORING**

If an electronic level monitor is installed, it must be calibrated to match the top of the 7150 valve body, which must correlate with 95% of the actual tank capacity.



Manufacturer: "OPW"  
 Model: "7150-4"  
 (4" represents size)  
 Manufacture Date:  
 "MFG MMY"  
 MM= Month YY=Year

**Figure 26 - Product Identification**

**TEST INSTRUCTIONS  
POPPET & FLOAT MOVEMENT  
FOR TESTABLE MODELS ONLY**

**TOOLS NEEDED FOR TESTING:**

1. 1/4" square drive extension or 3/8" square drive extension with 3/8" to 1/4" socket adaptor.
2. Torque wrench / 1/4" or 3/8" square drive ratchet wrench.
3. Pipe dope.
4. Flashlight (optional).

**TEST STEP 1:**

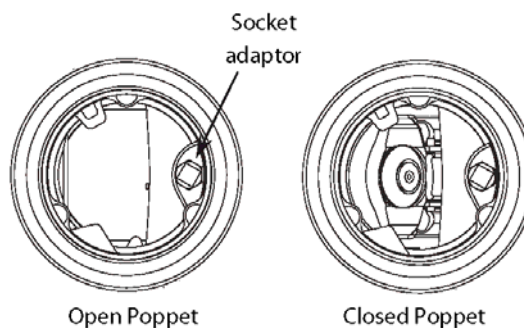
Remove spill container cover and fill cap from fill adapter and look down into the tube and make sure no debris or foreign objects are present. If debris or foreign objects are present take appropriate steps before proceeding. Look down into the tube and ensure poppet is completely protected by the deflection shield. See Test Figure 1. If poppet is exposed and tank is not full the overfill valve should be replaced. A flashlight may help when inspecting the tube.

**TEST STEP 2:**

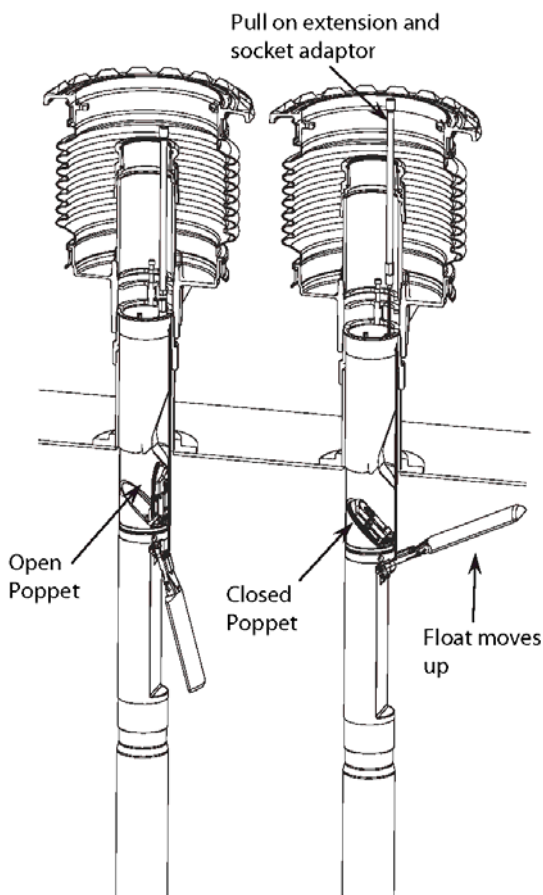
Unthread the socket adaptor assembly from the inlet tube using a 1/4" square drive extension and wrench. The extension will attach to the socket adaptor. Secure all tools to ensure they don't fall into the tank or valve. With the extension still attached pull on the socket adaptor and cable assembly and ensure float and poppet move / function properly. It should only require 3" to 4" of movement and less than 5 lbs of force in order to actuate the float and poppet. When looking down into the upper tube ensure poppet is visible and moves into the flow path (see Test Figure 1 & 2) when socket adaptor is pulled and resets properly when socket adaptor is released. If poppet does not actuate freely take appropriate steps to correct.

**TEST STEP 3:**

Apply pipe dope to the socket adaptor threads. Pipe dope should be a non-hardening gasoline resistant pipe thread seal compound. Make sure poppet and float have reset properly and are not visible then install socket adaptor and torque to 3.5 ft-lbs (42 in-lbs) minimum to 5.0 ft-lbs (60 in-lbs) maximum. After installing socket adaptor, to ensure vapor tightness, OPW recommends conducting pressure testing per CARB TP201.1D. Some areas may require pressure testing of overfill valve per CARB TP201.1D to ensure valve is vapor tight. If the drop tube fails pressure testing it may be necessary to check the seal at the poppet adaptor threads. Reinstall fill cap and spill container cover after testing.



**Test Figure 1**



**Test Figure 2**



**PREVENTATIVE MAINTENANCE**

Annually, inspect the flapper in the 7150 to see that it is open by looking down the drop tube opening. Test the 7150 drop tube seals with CARB procedure TP-201.1D. If the drop tube seal passes testing, no further maintenance is required. If the drop tube fails testing, replace the drop tube seal with OPW P/N: H11931M for 4" Tubes. Re-test the 7150 drop tube with CARB procedure TP-201.1D. The lower tube o-ring seal OPW P/N: H14840M can also be replaced. If this does not correct the leak the 7150 needs to be replaced.

**FOR TESTABLE MODELS ONLY:** The socket adaptor can be removed and poppet and float movement and function inspected without removing the valve. See Page 17 for full testing details. If replacement parts are needed for testable models the following items are available: OPW P/N 206741 Testable Inlet Tube S/A, 206740 Socket Adaptor and Cable Assembly, and 61SOK-0001 Float Kit.

**CAUTION: Do not insert any foreign object into drop tube if flapper is in the closed position. For example, a tank level measuring stick. This will damage the valve and void the Warranty. ALWAYS check flapper location before "sticking" the tank. If flapper is in the closed position, the tank is either over-filled and you need to wait until the liquid level goes down or the 7150 is damaged and needs to be replaced.**

**7150 Performance Specifications**

This Overfill Prevention Valve has been manufactured and tested to, and met, the following California specifi-

cations. Performance Requirement: Leak rate to be less than or equal to 0.17 CFH@2.0" W.C.

**Torque Specification**

Taptite Screws, #10-24 thread cutting, 20 in-lbs minimum to 35 in-lbs maximum. **Testable Models Only:** Socket Adaptor, 1/4" NPT, 3.5 ft-lbs (42 in-lbs) minimum to 5.0 ft-lbs (60 in-lbs) maximum.

**IMPORTANT: Leave these installation instructions and maintenance procedures with the station operator.**



3250 US 70 Business West  
Smithfield, NC 27577  
Customer Service: 1-(800) 422-2525  
Technical Service and Questions:  
1-(877) OPW-TECH  
[www.opwglobal.com](http://www.opwglobal.com)

Part Number:	H15524PA
Issue Date:	01/30/2014 REV L
Supersedes:	12/03/2013 REV K



## Installation and Maintenance Instructions

### OPW Multi-Port Spill Containment Manholes



Please read these warnings and assembly instructions completely and carefully before starting. Failure to do so may cause product failure, or result in environmental contamination due to liquid leakage into the soil, creating hazardous spill conditions.

**IMPORTANT:** The OPW Spill Container is pre-assembled for your convenience and ease of installation. Check to make sure the unit is intact and undamaged and all parts have been supplied. Never substitute parts for those supplied. Doing so may cause product failure.

**WARNING-DANGER:** Using electrically operated equipment near gasoline or gasoline vapors may result in a fire or explosion, causing personal injury and property damage. Be sure that the working area is free from such hazards, and always use proper precautions.

**NOTE:** At all times when product is in the storage tank keep the riser pipe capped, so the vapors cannot escape into the environment.

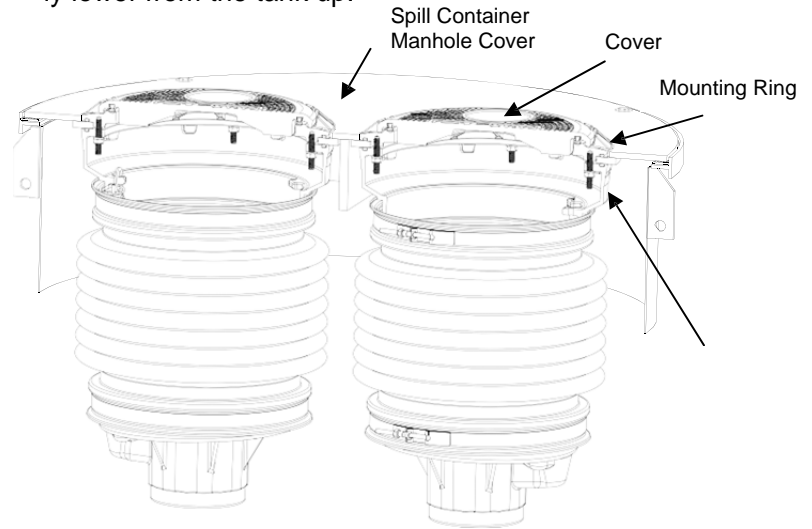
**Notice:** OPW products must be used in compliance with applicable federal, state, and local laws and regulations. Product selection should be based on physical specifications and limitations and compatibility with the environment and material to be handled. All illustrations and specifications in this literature are based on the latest production information available at the time of publication. Prices, materials, and specification are subject to change at any time, and models may be discontinued at any time, in either case, without notice or obligation.

This section intentionally left blank.

Notice: Flex-Works by OPW, Inc., VAPORSAVER™ and all other OPW products must be used in compliance with all applicable federal, state, provincial and local laws, rules and regulations. Product selection is the sole responsibility of the customer and/or its agents and must be based on physical specifications and limitations, compatibility with the environment and material to be handled. All illustrations and specifications in this literature are based on the latest production information available at the time of publication. Prices, materials and specifications are subject to change at any time, and models may be discontinued at any time, in either case, without notice or obligation.

**4" Nipple, 4" NPT**, 125 ft-lbs minimum to 250 ft-lbs maximum.

**NOTE:** All 4" NPT threads are to be torqued progressively lower from the tank up.



.This section Intentionally left blank.

**Date of manufacture on this product is located on the ID Tag on the mounting ring of the bucket.**

In California it is prohibited to use spill container drain valves on spill containers that are exclusively used for vapor return risers. Install only P Series or 1-2100-XSH Series Thread-On spill container models equipped with drain plug P/N 1DP-2100.

**Multi-Port Performance Specifications:**

This Spill Container drain valve has been manufactured and tested to the following California specifications: Leak Rate at 0.17 CFH @ 2.0" W.C.

**Torque Specification:**

**Spill Container 4" NPT**, 125 ft-lbs minimum to 250 ft-lbs maximum.

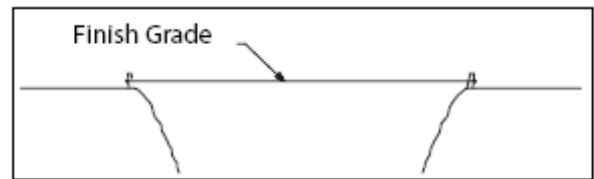
Drain Valve Clamps, 5/16-18 UN thread, 11.5 ft-lbs minimum to 13.5 ft-lbs maximum.

Mounting Ring Stud and Cover Bolts, 5/16-18 UN thread, 15 ft-lbs minimum to 20 ft-lbs maximum.

Roto-Lock Bolt, 1/2-13 UN thread, 40 ft-lbs minimum to 50 ft-lbs maximum.

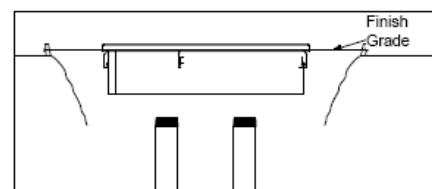
**OPW MULTI-PORT SPILL CONTAINER MANHOLE INSTALLATION INSTRUCTIONS**

1. Mark off finish grade. (See Figure 1).



**Figure 1**

2. Set multi-port manhole assembly (skirt, ring, and cover) to 1 inch minimum (for slope) above the final grade position. The weight of the multi-port assembly must be supported when set into place, this may require a partial backfill and support structure. (See Figure 2.)



**Figure 2**

**Note:** It is strongly recommended that OPW co-

vers be installed with the following minimum clearances. Sheet metal skirts should have adequate clearance between the tank sump riser side-wall and or the sump top hat. A minimum of one and a half inches clearance on all sides is recommended between the OPW skirt and the tank sump wall or the sump top hat wall. A minimum of two inches clearance is recommended between the bottom of the OPW skirt and the horizontal surface of the tank sump or sump top hat. These clearances are recommended to allow adequate water migration away from the sumps. Great care should be used to maintain the recommended clearances when setting the rings and pouring the concrete. (See Figure 3.)

3. Remove the cover and measure the distance from the top of the tanks to the final grade.

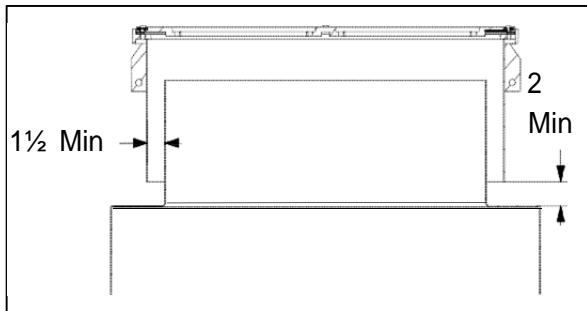


Figure 3

4. Cut the riser(s) from the underground tank so that both the fill and vapor risers are set below the final grade. Use the dimensions below:

Spill Container multiport (L)	Inches below top of
5 Gal. Cast Iron Base	18-1/2"
5 Gal. Composite Base	19-5/8"
7.5 Gal. Cast Iron Base	22-1/2"
7.5 Gal. Composite Base	23-5/8"

**NOTE:** Add an extra 3-1/4" when using an OPW FSA-400 and add an extra 1 3/4" when using the FSA-400S Face Seal Adaptor. (See Figure 2.) (Offset add extra 6"). Deburr and thoroughly clean riser pipe(s). Apply pipe dope to riser(s). The pipe dope is to be a non-hardening, gasoline resistant, pipe thread seal compound.

5. Install OPW FSA-400 Face Seal Adapter onto riser. (Recommend Torque, 4" NPT, 125 ft-lbs min. to 250 ft-lbs max.). Apply pipe dope to FSA-400. The pipe dope is to be a non-hardening, gasoline resistant, pipe thread seal compound. This is optional for spill containers that are on the vapor lines.
6. Thread on spill containers
7. Using the 61SA-TOOL, tighten the spill container (s) onto the riser(s) with a minimum torque of 125 ft.-lbs. and a maximum torque of 250 ft.-lbs.

**NOTE: Do NOT attempt to completely tighten the containment bucket by using the containment bucket mounting ring at the top of the bucket.**

**NOTE: Ground riser pipe(s) to nearest grounding rod.**

8. Inspect the containment bucket O-Rings and Mounting Ring O-Rings for damage. Replace the gasket(s) if they are damaged.
9. Install Optional Multi-Port Water Shroud (MPWS). See separate instructions.
10. Remove Spill Container Cover and Spill Container Mounting ring from Manhole Cover.
11. Replace the multi-port cover, centering the riser (t) as close as possible in the containment openings. Be very careful not to move or damage the O-Rings.
12. Remove lock washers and nuts from the studded mounting ring.
13. Place the mounting ring over the containment buckets and rotate the mounting ring until the studs are aligned with the bucket ring holes. (See Figure 4.)

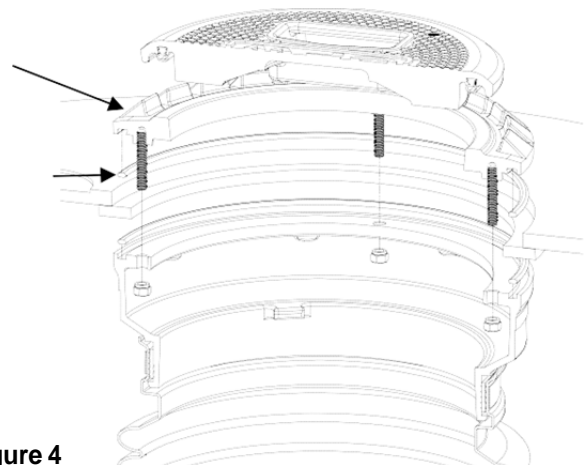


Figure 4

16. Thread nut and lock washer onto studded mounting ring. Tighten the mounting ring retaining bolts until the containment bucket o-rings make contact with the multi-port cover. Then, in a crossing pattern, torque the bolts down between 15 to 20 ft.-lbs. 6 Point Ratcheting box wrench is recommended. (See Figure 5.)

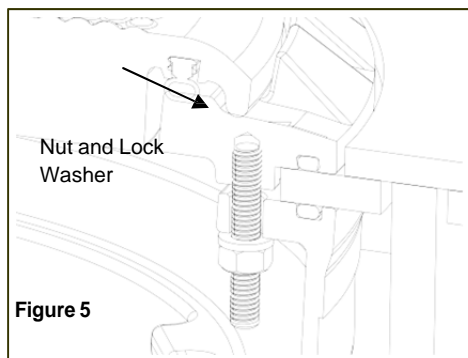


Figure 5

17. Install the spill bucket covers.
18. (Optional): Install the product identification disc on the spill bucket cover and multi-port cover in the I.D. discrecess.
19. Cover the multi-port perimeter ring and cover with plastic to prevent concrete from settling in the drainage areas.
20. It is required that the perimeter ring and skirt assembly, and the multi-port cover be set as an assembled unit, with the bolts engaged. Failure to engage the bolts may result in the distortion of the ring and improper fit of the ring to cover after the concrete is poured. Mounting ring bolts should be torqued to 15 ft-lbs minimum to 20 ft-lbs maximum. Roto-lock bolts should be torqued to 40 ft-lbs minimum to 50 ft-lbs maximum.
21. When pouring the concrete, hand shovel or trowel the concrete around the multi-port assembly to prevent the unit from moving or shifting, which can cause alignment problems and future maintenance problems.

**NOTE: Do not stand on the multi-port before the concrete has set up.**

22. It is required that the paved contours around POMECO covers be adequately sloped to direct water flow away from the cover, and directing water runoff from adjacent areas away from POMECO covers.

Minimum slope is 1" from grade to the top of the ring of the manhole. Note that this slope must be taken into consideration when cutting riser lengths in earlier steps. (See Figure 7.)

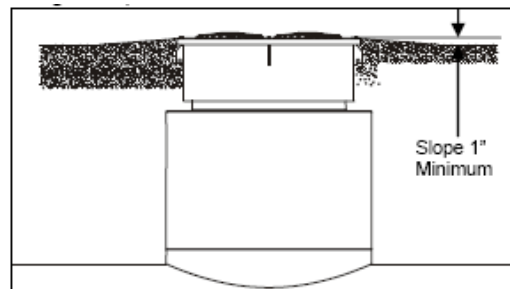


Figure 7

23. Remove the plastic after the concrete has set up. In areas where excessive surface water may be seen, it is recommended to caulk joint around perimeter of cover and perimeter ring with SL1100 sealant.
24. After installation is complete, water test the multi-port fixture. The recommended water test procedures include:
  - a. Spraying water on cover(s) for 5 to 10 minutes, using a commonly available watering device such as a lawn sprinkler.
  - b. Standing water test, not to exceed 1/2" in water depth for a period of 5 to 10 minutes.

If water is found on the interior of the spill container or on the skirt (which can be checked through the observation port) that is not due to condensation; determine the root cause of the leak, repair the seal, and retest the unit.

**NOTE:** The containment bucket consists of three components cast iron ring, bellows, and bucket bottom. These parts are held together with stainless steel retaining bands.

**DO NOT loosen the stainless steel retaining bands** securing the bellows to the containment bucket top ring or the spill containment bucket bottom. Loosening the retaining bands voids any and all warranties on this product.

**WARNING:** If the cover is removed, for any reason, follow the Service and Maintenance Instruction (Part Number 202490) as noted. Always inspect and replace damaged O-rings and install new O-rings. Never reuse damaged O-rings as it may result in an improper seal.

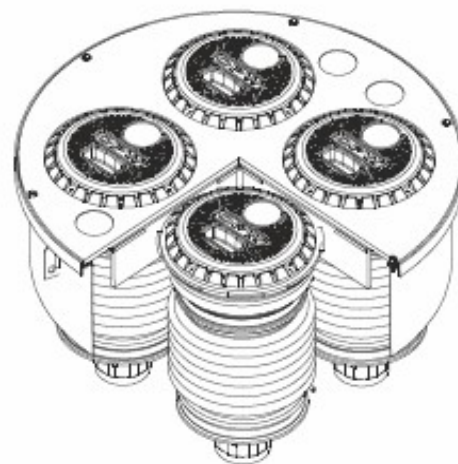
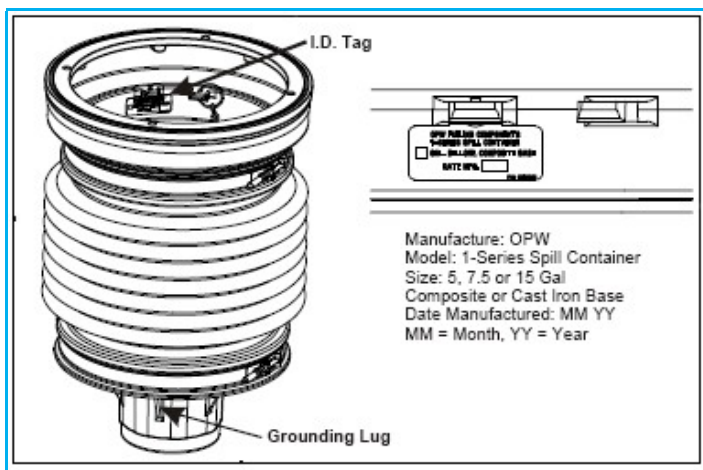
**Operation and Maintenance:**

Annually: Inspect and clean the interior of the spill container and drain valve screen. Remove accumulated dirt and grit. If the drain valve screen becomes clogged, remove the valve, soak in water and use high-pressure air to clean. Reinstall the drain valve to its proper position and test the valve per the appropriate test procedure. If problems persist, replace the drain valve with P/N 1DK-2100-EVR (specified torque 11.5 ft-lbs min to 13.5 ft-lbs max, 5/16-18 UN thread). The sealable cover (1SC) adjustment nut is set at the factory, but due to environmental conditions it may be necessary to adjust it to either improve sealing or ease cover removal.

**NOTE:** Common sense and good judgment should always be exercised. The contractor’s understanding of all related site conditions prior to starting the project is essential. If the contractor does not have a clear understanding of the required work and site conditions, the contractor is advised to seek clarification prior to starting any portion of the project.

**IMPORTANT: Leave these instructions with the Station Operator as per CARB Requirements.**

**Alternative Construction**



**Testing Spill Containers**

Use TP201-1C or TP201-1D test procedures. Their Test Procedures will check the seals between the drain valve, nipple and rotatable adapter. To test the spill containers base and bellows fill the container with water. A drop in the water level of 1/16” or greater after one hour means that a leak exists. To determine where the leak is, look for a steady stream of bubbles coming from one of the joints or water leaking on the outside of the bucket. NOTE: Do not drain the water into the UST after the test is complete. Water must be disposed of per local requirements for hazardous waste. If the leak cannot be corrected the spill container should be replaced with another.

OPW recommends periodic inspection of covers and seals as a part of the regularly scheduled maintenance program. If any of the seals are damaged they should be replaced. Only qualified, competent, well-trained technicians should perform maintenance.



This page intentionally left blank.



**OPW Fueling Containment Systems**

3250 US 70 Business West  
Smithfield, NC 27577  
Customer Service: 1-(800) 422-2525  
Technical Service and Questions:  
1-(877) OPW-TECH  
[www.opwglobal.com](http://www.opwglobal.com)





## Fibrelite Multiport Installation and Maintenance Instructions

Please read these warnings and use and assembly instructions completely and carefully before starting. Failure to do so may cause product failure, or result in environmental contamination due to liquid leakage into the soil, creating hazardous spill conditions.

**OPW Standard Product Warranty Tag:** Notice: Flex-Works by OPW, Inc., VAPORSAVER™ and all other OPW products must be used in compliance with all applicable federal, state, provincial and local laws, rules and regulations. Product selection is the sole responsibility of the customer and/or its agents and must be based on physical specifications and limitations, compatibility with the environment and material to be handled. All illustrations and specifications in this literature are based on the latest production information available at the time of publication. Prices, materials and specifications are subject to change at any time, and models may be discontinued at any time, in either case, without notice or obligation.

OPW warrants solely to its customer (the initial purchaser and any subsequent purchasers within the warranty period) that the following products sold by OPW will be free from defects in materials and workmanship under normal use and conditions for the periods indicated:

PRODUCT	WARRANTY PERIOD
FlexWorks Primary Pipe	10 years from date of manufacture
All Products and replacement parts installed in the State of California Certified to California CP-201 and/or CP-206 Standards*	1 year from date of installation (proof of purchase from certified contractors/technicians required) OPW warrants ongoing compliance with the standards and specifications for the duration of the warranty period required by the State of California; this limited warranty is under the condition the equipment was installed and maintained by trained and certified contractors/technicians unless noted in Installation Manual.
All other Products and replacement parts	1 year from date of manufacture**
*Products certified to California CP-201 and/or CP-206 Standards have been factory tested and met all applicable performance standards and specifications and will have an OPW registration card enclosed/attached to the product.	

OPW's exclusive obligation under this limited warranty is, at its option, to repair, replace or issue credit (in an amount not to exceed the list price for the product) for future orders for any product that may prove defective within the applicable warranty period. (Parts repaired or replaced under warranty are subject to prorated warranty coverage for remainder of the original warranty period). Complete and proper warranty claim documentation and proof of purchase required. All warranty claims must be made in writing and delivered during the applicable warranty period to OPW at OPW 9393 Princeton-Glendale Road Hamilton, Ohio, USA 45011, Attention: Customer Service Manager. No products may be returned to OPW without its prior written authority.

This limited warranty shall not apply to any FlexWorks or VAPORSAVER™ product unless it is installed by an OPW attested installer and all required site and warranty registration forms are completed and received by OPW within 60 days of installation. This limited warranty also shall not apply to any FlexWorks, VAPORSAVER™ or other OPW product: unless all piping connections are installed with a nationally-recognized or state-approved leak detection device in each tank and dispenser sump (which are not for storage and from which all discharge hydrocarbons must be removed, and the systems completely cleaned, within 24 hours); unless testable sumps utilize FlexWorks pipe and access fittings; unless a sump inspection log or an EPA recommended/required checklist is maintained and the results are furnished to OPW upon request; and unless OPW is notified within 24 hours of any known or suspected product failure and is provided with unrestricted access to the product and the site. This limited warranty also shall not apply to any product which has been altered in any way, which has been repaired by anyone other than a service representative authorized by OPW, or when failure or defect is due to: improper installation or maintenance (including, without limitation, failure to follow FlexWorks Quick Reference Manual Installation Guide and all product warning labels); abuse or misuse; violation of health or safety requirements; use of another manufacturer's, or otherwise un-authorized, substances or components; soil or other surface or subsurface conditions; or fire, flood, storm, lightning, earthquake, accident or any other conditions, events or circumstances beyond OPW's control.

THIS LIMITED WARRANTY IS IN LIEU OF ALL OTHER WARRANTIES, EXPRESS OR IMPLIED, AND ALL OTHER WARRANTIES INCLUDING, WITHOUT LIMITATION, THE WARRANTIES OF MERCHANTABILITY AND FITNESS FOR A PARTICULAR PURPOSE, ARE HEREBY EXCLUDED.

OPW shall have no other liability whatsoever, whether based on breach of contract, negligence, gross negligence, strict liability or any other claim, including, with-out limitation, for special, incidental, consequential or exemplary damages or for the cost of labor, freight, excavation, clean-up, downtime, removal, reinstallation, loss of profit, or any other cost or charges. No person or entity is authorized to assume on behalf of OPW any liability beyond this limited warranty. This limited warranty is not assignable.

**\*\* Date of manufacture on this product is located on the spill container.**

In California it is prohibited to use spill container drain valves on spill containers that are exclusively used for vapor return risers. Install only OPW Thread-On spill containers models equipped with drain plug P/N 1DP-2100.

**IMPORTANT**

Read these assembly and installation instructions completely and carefully prior to starting. Check to make sure all parts have been provided. Use only the parts supplied; substitution of parts may cause product failure.

**Multi-Port Performance Specifications:**

This Spill Container drain valve has been manufactured and tested to the following California specifications: Leak Rate at 0.17 CFH @ 2.0 " W.C.

**Torque Specification:**

**Spill Container 4" NPT**, 125 ft-lbs minimum to 250 ft-lbs maximum.

**4" Nipple, 4" NPT**, 125 ft-lbs minimum to 250 ft-lbs maximum.

**Note:** All 4" NPT threads are to be torqued progressively lower from the tank up.

Drain Valve clamps, 5/16-18 UN thread, 11.5 ft-lbs minimum to 13.5 ft-lbs maximum.

Ring Bolts and Nuts, 5/16-18 UN thread, 15 ft-lbs minimum to 20 ft-lbs maximum.

Shroud boot band clamps, 60 in-lbs.

**TOOLS NEEDED FOR INSTALLATION AND ASSEMBLY:**

1. FL7A Lifting handle
2. Pipe wrench
3. Level
4. Tape measurer
5. Permanent marker
6. Torque wrenches (ft-lb and in-lb)
7. ½" combination wrench
8. Ratchet and sockets including: ½" socket, 7/16" deep socket, 9/16" socket, 7/8" socket.
9. Socket extensions
10. Caulk gun
11. Pipe dope
12. Silicone lubricant spray
13. Caulk gun
14. 61SA-TOOL (optional)
15. 1-3100-TOOL (optional)
16. TC-400 Torque cap (optional)
17. DW-VAC-TEST Vacuum Test Kit (optional)
18. SC-TEST Test Cover (optional)

Items needed for new installs only:

19. String line
20. Jigsaw or angle grinder with diamond blade
21. Heavy grit sandpaper
22. Acetone
23. Tank sump vacuum test equipment (optional)

Items needed for retrofit of steel multiports only

24. Concrete saw.

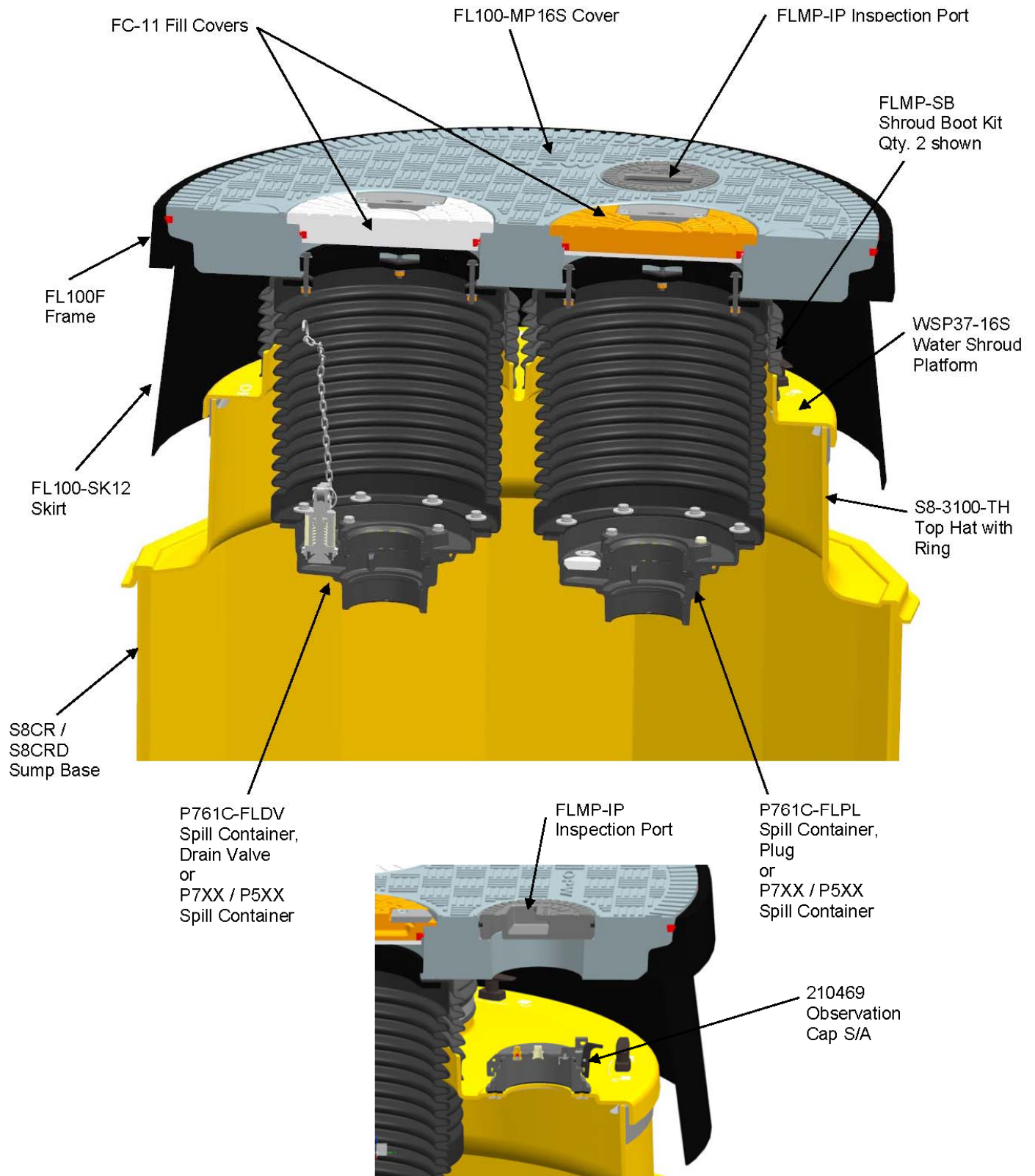
**WARNING**

Using electrically operated equipment near gasoline or gasoline vapors may result in fire or explosion, causing personal injury and property damage. Check to assure the working area is free from such hazards, and always use proper precautions.

**NOTE:**

Do not store sumps on their sides prior to installation. Failure to do so may cause sump to deform preventing installation on the round tank collar.

### Fibrelite Multiport Parts Diagram



- For new installations with OPW / Fibrelite single wall tanks sumps proceed to step 1 on page 5.**
- For new installations with double wall tank sumps proceed to step 34 on page 12.**
- For retrofit installations replacing an existing steel multiport proceed to step 38 on page 13.**
- For retrofit installations replacing an existing Fibrelite FL100 cover proceed to step 49 on page 16.**

**Fibrelite Multiport Spill Container  
Installation Instructions for new installation with  
OPW / Fibrelite single wall tank sump.**

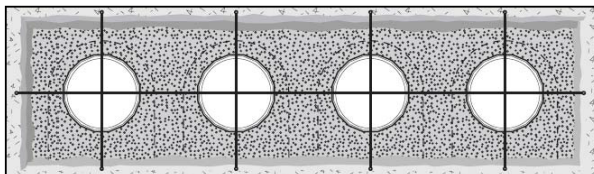
**IMPORTANT:**

For best results, OPW / Fibrelite Fiberglass Tank Sumps should be installed when the ambient temperature is at least 50°F to allow proper curing of the epoxy resin adhesive. (See RK-5000 Resin Kit Instruction Sheet).

Do not exceed Maximum Sump Burial Depth:  
S8, S14, S15 = 94".

1. Install string lines at finished grade level (manhole grade level) across the length and width of the tank farm (as shown in Figure 1) in order to accurately measure the distance from grade level to the tank top.

Note: The cover frame will be set 1 inch minimum (for slope) above the final grade position.



**Figure 1**

2. Mount the tank sump base to the UST. OPW / Fibrelite tank sumps can be mounted to the top of the UST using one of the following methods:

**Method 1: Mounting Flanges (not shown)**

Attaches the base of the sump to tank bung fittings using Flexworks Sump Mounting Flanges - FlexWorks Product Numbers:

- SMF-4E\* 4" NPT Mounting Flange
- SMF-6\* 6" NPT Mounting Flange
- TFA-4090 4" No Bolt Style

\* See Installation Instructions supplied with FlexWorks Sump Mounting Flanges. Ensure dimensions in steps 4 and 5 are met.

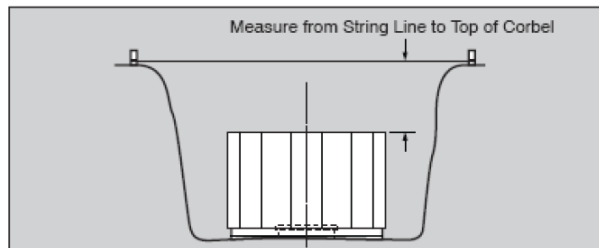
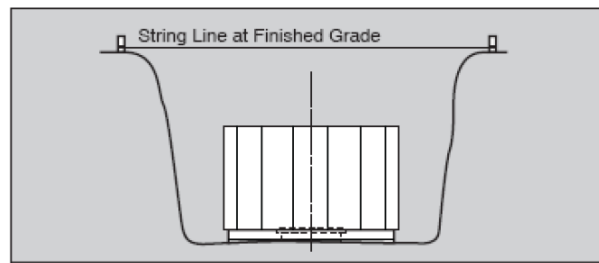
**Method 2: Collar Mount**

The sump is attached to the containment collar on an FRP tank by attaching the sump base to the collar using a FlexWorks Resin Adhesive Kit (Product Number RK-5000).

**NOTICE:** Many mounting kits supplied by other manufacturers are not warranted by OPW. OPW bears no responsibility

whatsoever for the integrity of joints using alternate tank sump mounting systems.

3. **For collar mount installation.** Measure across the tank collar and ensure it is the same size as the tank sump before proceeding. Place the sump bases onto each of the tank collars ("dry fit" the sump base at this stage). Mark the sump to reflect the tank it is installed on. Measure the distance from the string line to the top of the sump and note the measurement in a log or on the side of the sump.



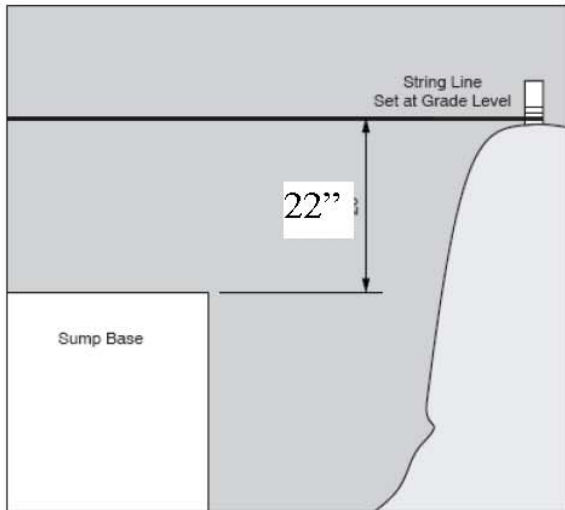
**Figure 2**

4. The top of the sump base must be 22" below the string line set at finished manhole grade level. This will provide sufficient clearance for both the OPW / Fibrelite top hat and the water shroud platform. See Figure 3.

If trimming is required to meet the 22" dimension proceed to step 5. If no trimming is needed proceed to step 6.

If the sump base is more than 22" below the string line, it will be necessary to install an extension and trim it so the combined sump base and extension are 22" below the string line. If the sump base is less than 11" from the string line, it will be necessary to use a shorter sump base. The S8 series sumps have deep and normal sump bases and extensions to handle such issues.

**Note:** For more detail, see figure 52 showing finished fill sump installation with critical dimensions.

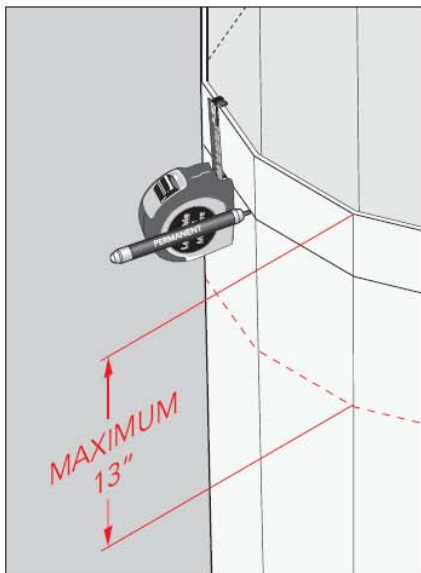


**Figure 3**

5. If the sump base must be trimmed, mark the trim line on the sump base using a permanent marker - make sure to mark a level line on the tank sump for cutting (use a locked tape measure as shown in Figure 4). If the line is not level, re-measure and re-mark until the marked line is correct and level. The sump and top hat will not seal properly if the cut is jagged or uneven.

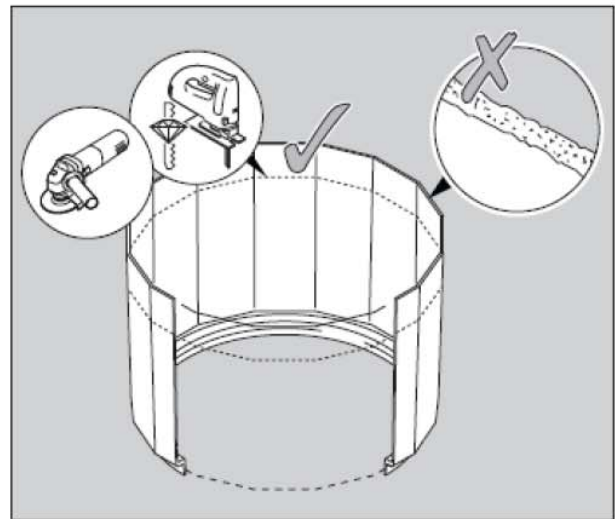
**Note:**

The S8 sump may be trimmed a maximum of 13" from the top. If this is not sufficient, a shorter sump base will be required.



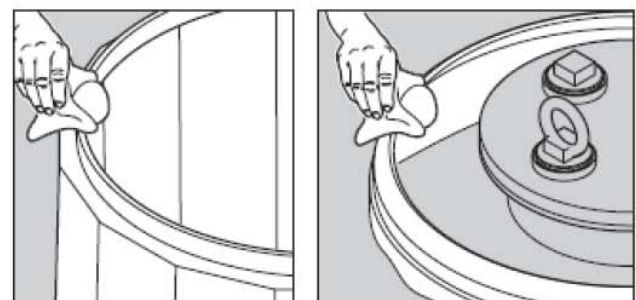
**Figure 4**

6. Use a jigsaw or angle grinder with a diamond grit blade to trim the top of the sump at the marked line from step 5. Ensure that the sump is cut evenly. A jagged or uneven cut must be corrected before proceeding.



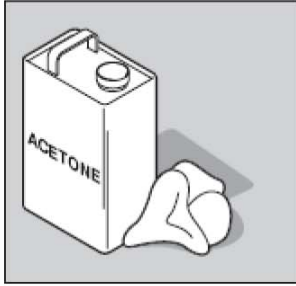
**Figure 5**

7. The surface of the tank collar and sump base must be prepared properly prior to fiberglassing. Using heavy grit sandpaper, completely roughen the surface of both the sump collar and the sump base where they will be joined. Sand both the internal and external sides of the collar and sump base.



**Figure 6**

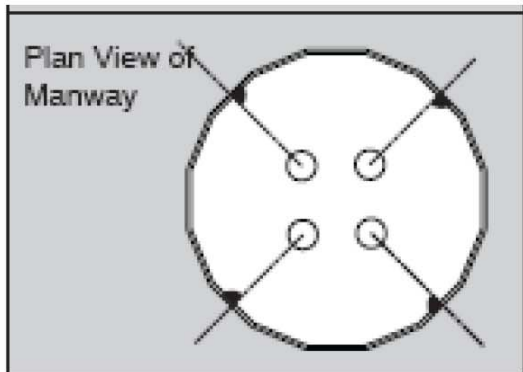
8. All sanded surfaces must be wiped clean with acetone and a clean cloth immediately prior to fiberglassing to ensure that no dust, dirt, grease, or oil are present on the surfaces. The surfaces must be free from moisture and other contaminants.



**Figure 7**

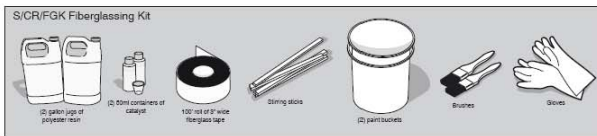
9. Immediately after cleaning, install the tank sump onto the tank collar.

Note: Prior to fibreglassing the sump to the tank collar, dry fit it onto the collar and position so that the sump facets align perpendicular with the pipework exit/entry points (see Figure 8).



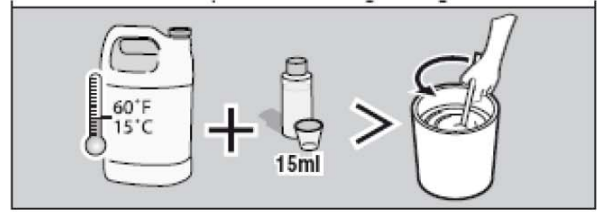
**Figure 8**

10. Use a level to set the sump base on collar. Make sure the sump will be level to finished grade. Ensure the 22" dimension in Figure 3 is correct.
11. Attach the sump base to the tank collar using the S-CR-FGK fibreglassing kit. Detailed tank collar fibreglass instructions are packed in fibreglassing kit.



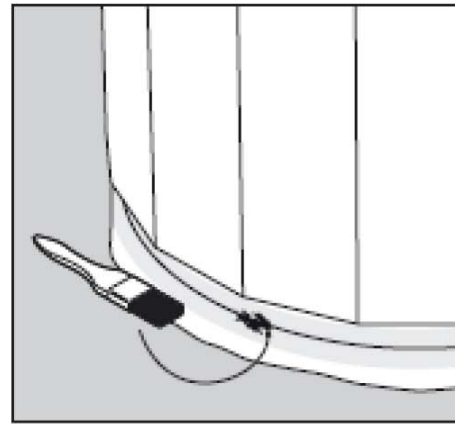
**Figure 9**

12. At 60°F, mix 1 quart resin with 15 ml catalyst and stir well.



**Figure 10**

13. Using brush, paint resin onto sanded surfaces at the tank collar joint. Apply resin around circumference of the tank collar.

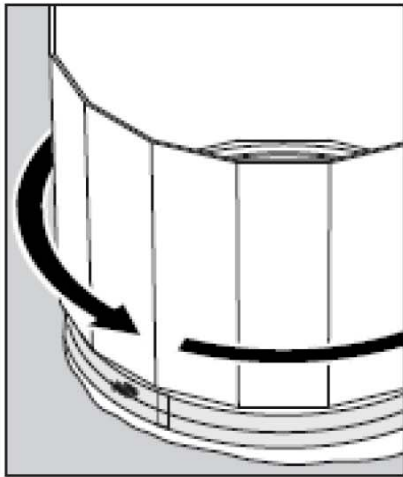


**Figure 11**

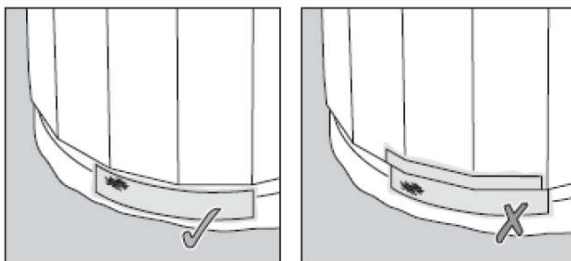
14. Apply a layer of fiberglass tape by centering it on the tank collar joint and unrolling it completely around the sump keeping it centered over the joint (this will require 2 people). Cut the tape once the first layer is applied.

Apply fiberglass tape only at the tank collar to tank sump joint. Fibreglassing on the sump body may cause distortion after the resin has dried. See Figure 13.



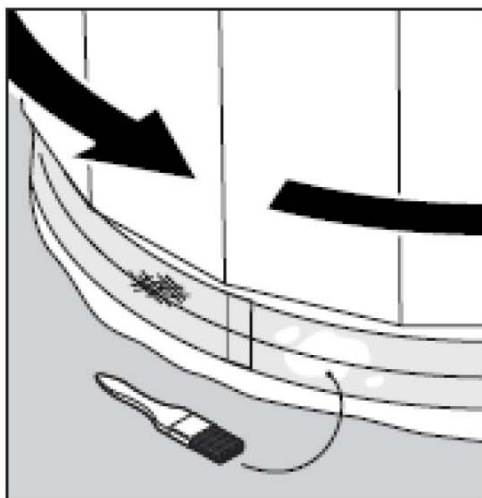


**Figure 12**



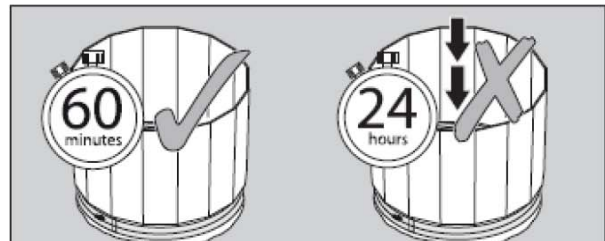
**Figure 13**

15. Apply a second and third layer of fiberglass tape by repeating steps 13 and 14 ensuring that all joints are staggered and overlap by a minimum of 2 inches. Paint a final layer of resin onto the third layer of fiberglass and use the brush to flatten out any bubbles or air pockets.



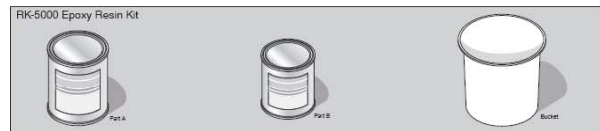
**Figure 14**

16. Allow a minimum of one hour for the resin to cure before proceeding with any other work on the tank sump. Allow 24 hours before putting any stress on the sump.



**Figure 15**

17. In addition to fiberglassing the outside tank collar joint, the inner tank collar joint should be filled with an epoxy resin to ensure that the joint will be watertight. Use part number RK-5000 Epoxy Resin Kit and follow detailed instructions packed with kit.



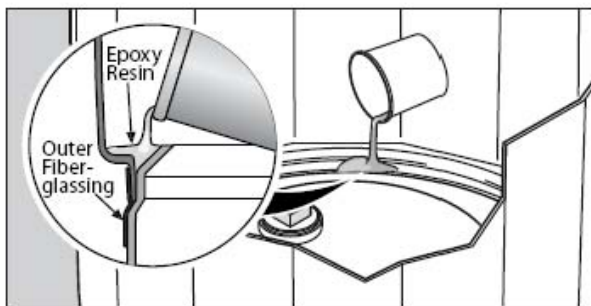
**Figure 16**

18. Surfaces previously sanded in step 7 should be cleaned again with acetone to remove contaminants.
19. For best results, the epoxy should be stored and mixed at room temperature. If the temperature is below 60°F, the adhesive must be warmed and mixed indoors. Pour the entire contents of Part A and Part B into mixing container. Thoroughly mix the adhesive with the provided mixing stick or with a drill mounted mixing paddle at low speed for a minimum of three (3) minutes. Be sure to scrape the bottoms and sides of the container to ensure proper and complete mixing.
20. Apply epoxy resin by pouring the epoxy into the joint between the tank collar and the tank sump."
21. Pour the entire mixture into the joint as shown in Figure 17. Allow adhesive to set-up undisturbed until it is hard.

Important: Resin Set-up Times

After joining the sump base to the collar allow the epoxy resin adhesive to harden before proceeding. Carefully follow the instructions supplied with the RK-5000 Epoxy Resin Kit and observe minimum set-up times before proceeding.

**DO NOT BACKFILL OR CONTINUE WORK IN OR AROUND THE SUMP UNTIL THE EPOXY IS COMPLETELY CURED.**



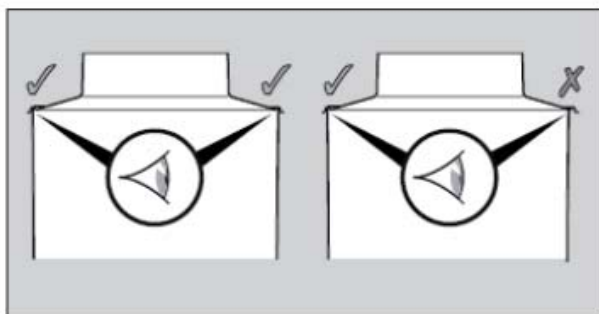
**Figure 17**

22. Install the appropriate FlexWorks pipe and conduit entry fittings into the flats around the tank sump base at the proper locations (Refer to the appropriate FlexWorks Entry Fitting Installation Instructions).

**Determining Pipe Entry Height**

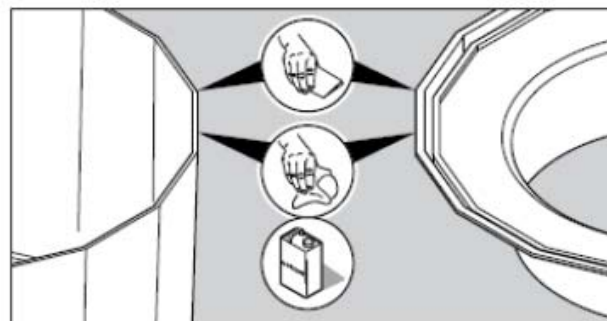
Pipe entries are generally located as close to the bottom of the tank sump as possible. The lower the pipe entry into the tank sump wall, the easier it will be to maintain the proper piping slope back to the UST from the dispensers.

23. Place the sump top hat (S8-3100-TH or similar) onto the tank sump base to ensure it will fit. Push top hat groove onto sump base wall ("dry fit" the sump top hat at this stage). The top hat should sit evenly all the way around. See Figure 18.



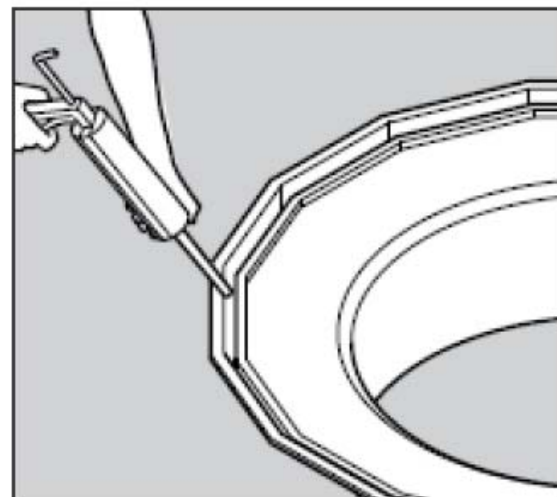
**Figure 18**

24. Measure the distance from the string line to the top of the top hat. This dimension should measure between 10.5" to 11.5". If this dimension is not met adjustments must be made before proceeding.
25. Remove top hat from sump base. As done in steps 7 thru 9 for the tank sump base using heavy grit sandpaper, completely roughen the surface of both the sump base and the downward facing groove on the top hat where they will be joined. Sand both the internal and external sides of the sump base and top hat. Clean all sanded surfaces with acetone.



**Figure 19**

26. Apply two to three tubes of RK-6000 Epoxy Resin in the groove of the top hat. Resin should fill at least half of the groove.



**Figure 20**

27. Place the top hat on the sump base using two people and push it into position.



**Figure 21**

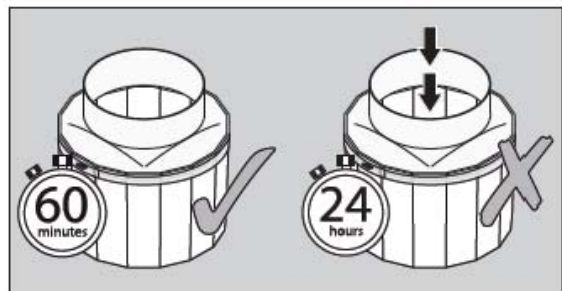
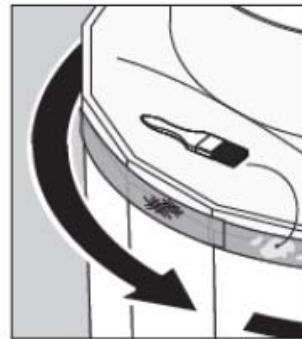
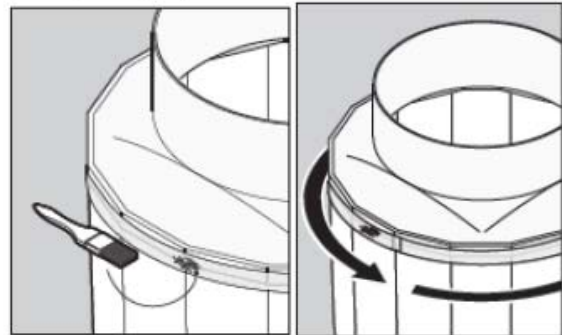
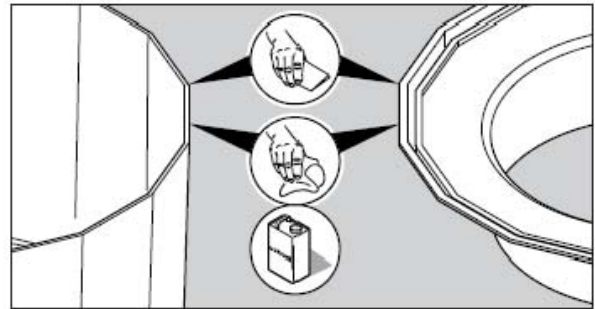
28. Smooth off the epoxy resin inside the joint and around the outside of the joint.
29. Allow adhesive to set-up undisturbed until it is hard.

Important: Resin Set-up Times

After joining the sump top hat to the sump base allow the epoxy resin adhesive to harden before proceeding. Carefully follow the instructions supplied with the RK-6000 Epoxy Resin and observe minimum set-up times before proceeding.

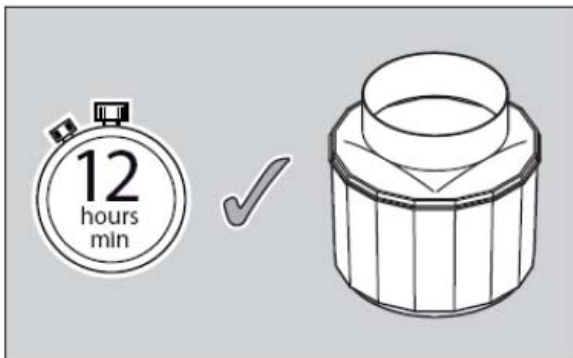
**DO NOT BACKFILL OR CONTINUE WORK IN OR AROUND THE SUMP UNTIL THE EPOXY IS COMPLETELY CURED.**

30. (Optional) If desired the top hat can be fibreglassed to the sump base. Similar to steps 7 thru 16 the top hat can be fibreglassed to the sump base using the S-CR-FGK fibreglassing kit. After sanding and cleaning, mix resin and paint onto sanded surfaces followed by three layers of fiberglass tape and a final coat of resin. See figure 22. Allow a minimum of one hour for the resin to cure before proceeding with any other work on the tank sump. Allow 24 hours before putting any stress on the sump.



**Figure 22**

31. Wait a minimum of 12 hours before vacuum testing sump, preferably overnight to allow epoxy resin to set before vacuum or hydrostatic testing.



**Figure 23**

**32. Leak Testing**

OPW recommends the following procedure for hydrostatic testing of tank sumps

1) Visually inspect all entry boots for band clamps, compression rings and donuts for possible leak points prior to testing. Correct as needed.

2) Be sure all test tubes, connector tubes or any other open secondaries into the sump are sealed and liquid tight.

3) Fill all sumps to a minimum of 1" above the highest penetration fitting or sump joint. Mark the liquid level with a permanent marker.

4) Hydrostatic test should be held for 1 hour or per local regulations.

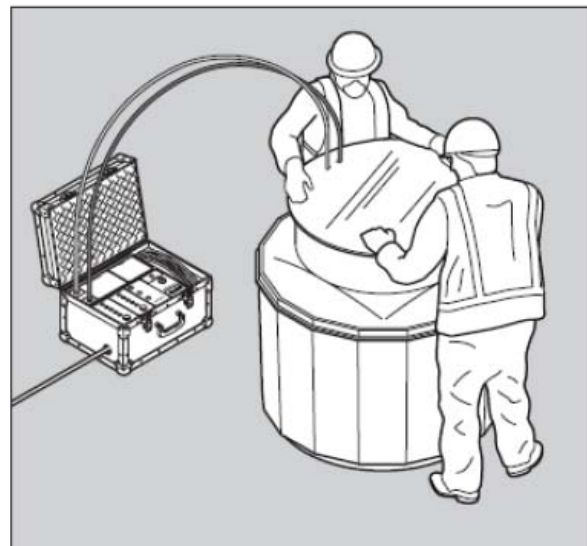
5) Be sure all water is disposed of properly after completing the test.

**Note:** Should the liquid level drop during testing, visually identify the leak source. Remove water and tighten band clamps to 30 in/lbs. Entry boot compression rings should be tightened in a clockwise manner until each stud reaches 60 in/lbs. Repeat testing procedure.

As an alternate to a hydrostatic test a vacuum test can be performed on the tank sump.

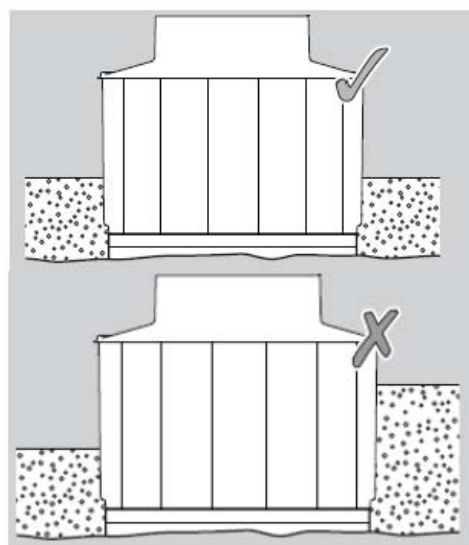
Warning: If vacuum testing, test the sump at a 24" depth setting only or irreparable damage may occur.

Refer to vacuum testing instructions for correct method.



**Figure 24**

33. Once the sump and top hat have successfully passed tightness testing, the area around the sump can be carefully backfilled. Rounded pea gravel with a minimum diameter of 1/8" and a maximum diameter of 3/4" must be used for backfill around OPW / Fibrelite Tank Sumps. To prevent sump damage, avoid dumping pea gravel directly onto the Tank Sump when backfilling. Backfill equally around the sump in layers to prevent damage or deformation.



**Figure 25**

**For new installations with OPW / Fibrelite single wall tanks sumps proceed to step 47 on page 15.**

**Fibrelite Multiport Spill Container  
Installation Instructions for new installation with  
double wall tank sump.**

34. Three methods are currently available to adapt the Fibrelite multiport spill container system to double wall tank sumps. These include:
  - a. Factory installed WS-RING-37 onto Western Fiberglass, Xerxes, or similar double wall tank sump.
  - b. Double wall tank sump and cover adapted for use with OPW / Fibrelite multiport spill container system. Containment Solutions model DW PTS-FBS (WT34) (FV2/15/16) 42/8 fill / vapor sump or similar.
  - c. Field installed top hat (S42 or S48) or riser attached to top of double wall sump.
- Note:** If installed in California the sump and spill container configuration must meet the requirements of California AB 2481.
35. For all options follow all instructions supplied by tank sump manufacturer. In all cases the 10.5" to 11.5" distance from the string line to the top of the top hat must be maintained.
36. For option C follow instructions supplied with top hat or riser. Steps 23 thru 30 above include instructions for this option.
37. Once the sump and top hat have successfully passed tightness testing per the manufacturers recommendations, the area around the sump can be carefully backfilled. Backfill around the sump per the sump manufacturers recommendations. See step 33 for OPW recommendations.

**For new installations with double wall tanks sumps proceed to step 47 on page 15.**

**Fibrelite Multiport Spill Container  
Installation Instructions for retrofit installations  
replacing an existing steel multiport**

- 38. Ensure existing multiport configuration matches current steel multiport. Examples include 16" spacing dual ports or 8" offset single port. If new Fibrelite multiport does not match the existing configuration do not proceed.
- 39. Ensure existing adapters are on center with existing ports. Adapters should be within approximately 1" radially of port center. If adapters are too far off center a retrofit may not be possible (See Figure 29.)
- 40. Ensure sump / top hat installed under cover is sized properly (or can be adapted) to work with the new multiport system. New multiport requires a WS-RING-37 upper ring be installed for attachment to water shroud platform.
- 41. Ensure sump / top hat installed under cover can be adapted to meet the dimensions shown in Figure 27.
- 42. Ensure riser heights can be adjusted to meet dimensional requirements shown in Figure 27.

**Note:** For use of P7XX or P5XX buckets with adapter ring see Figure 53 in Appendix on page 26 for riser height dimensions.

**Note:** Ensure electrical connections and other equipment will not interfere with new spill buckets.

- 43. If desired, the existing drop tube / overfill valve can potentially be used with the new installation. Determine mounting location of current drop tube / overfill valve (See Figure 27 for 3 possible options).

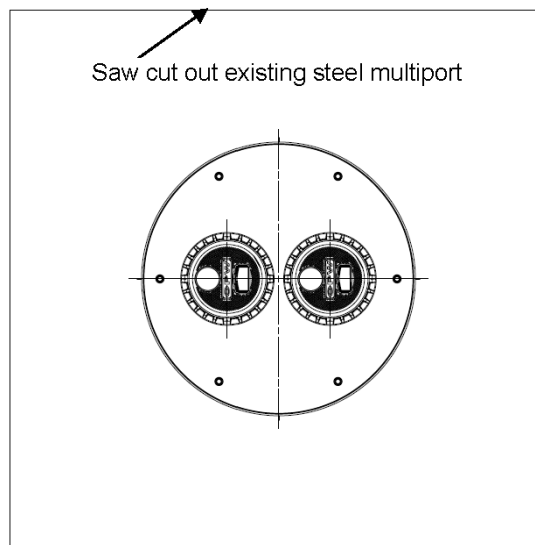
Location "A" - If drop tube / overfill valve is mounted at the adapter (location "A") the drop tube / overfill valve can be used as is if the grade to adapter height is maintained. Measure existing grade to adapter height and maintain with new configuration. Confirm dimensions meet requirements in the drop tube / overfill valve instructions when reinstalling.

Location "B" – If drop tube / overfill valve is mounted in the bottom of the spill container

(on FSA face seal adapter) the valve will need to be adjusted or replaced to meet the dimension in the new configuration. The nominal dimension from grade to sealing face in base of new spill container is 23 inches. Drop tube / overfill valve will need to be adjusted or replaced accordingly. Confirm dimensions meet requirements in the drop tube / overfill valve instructions when reinstalling.

Location "C" – If tee remains in same location the drop tube / overfill valve can be used as is.

- 44. Saw cut out existing steel multiport. Frame on new composite FL100 multiport is approximately 45 inches in diameter. Ensure saw cut is large enough to accommodate new frame (approximately 7 feet square). See Figure 26.



**Figure 26**

- 45. Remove any existing shrouds and buckets.
- 46. Install top hat / riser with WS-RING-37 to meet the 12 inch dimension from grade to top hat shown in Figure 27. Follow instructions supplied with top hat or riser. Steps 23 thru 30 may apply.

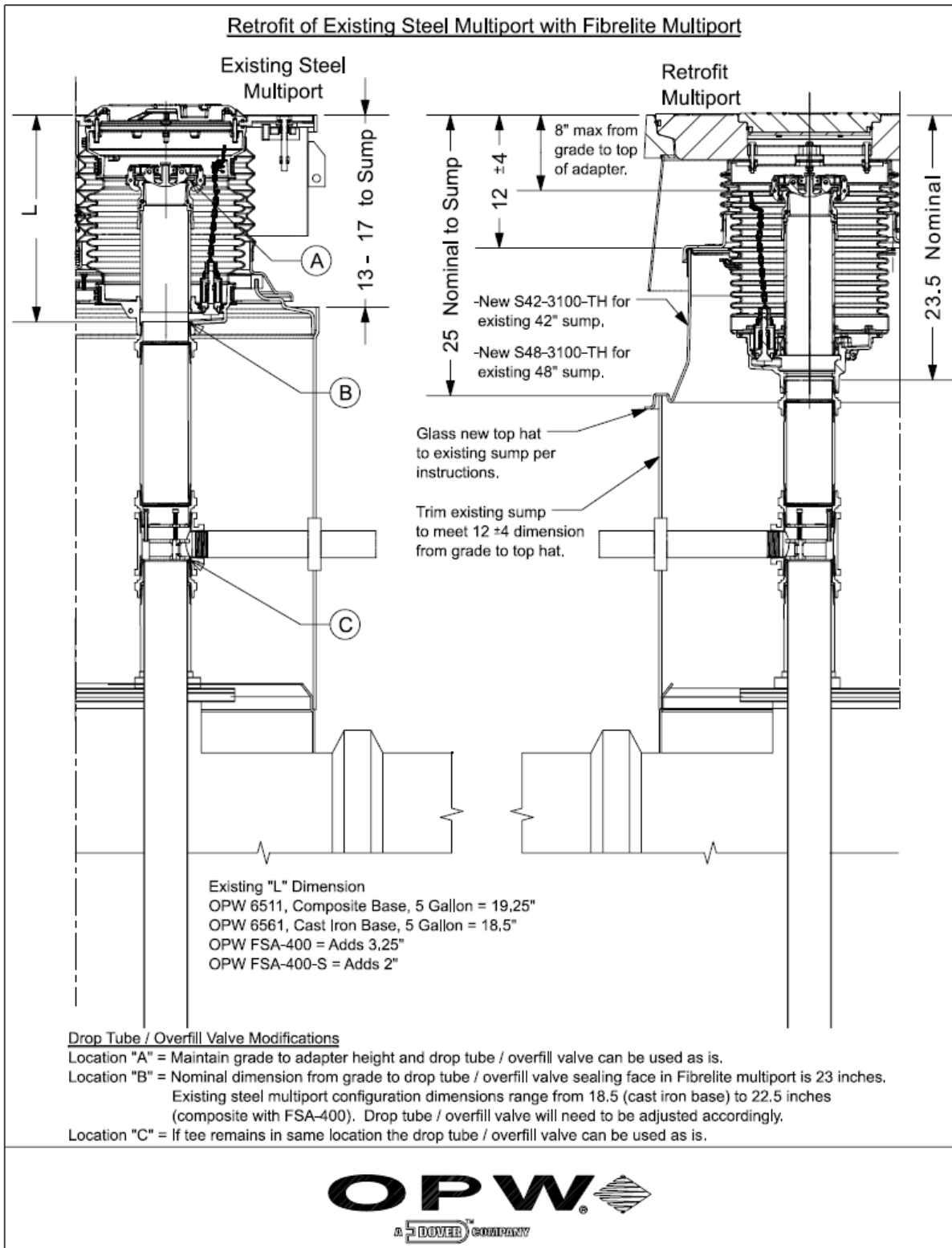


Figure 27

**Fibrelite Multiport Spill Container  
Installation Instructions for aligning / installing  
the skirt and frame**

47. After the sumps have been installed and backfilled, the multiport or offset fill covers can be installed. The FL100F frame must be carefully installed to ensure the fill and vapor port openings will line up properly above the risers. In order to position the frame so that the centerline of the fill and vapor ports are positioned directly over the fill and vapor risers, the FL100F frame must be positioned so that the centerline of one of the 15 flat facets on the frame is 180 degrees opposed from the point of the opposite facet (as shown in Figure 28). Also, the desired orientation of the observation port must be considered. If a sensor or other accessory in the sump needs to line up with the observation port there are two possible orientations available and the frame must be rotated to match accordingly.

48. After the frame orientation has been selected set the multiport cover, frame, and skirt to 1" minimum (for slope) above the final grade position. The weight of the multiport assembly must be supported when set into place. This may require a partial backfill and support structure. Ensure fill and vapor ports align with risers and observation port is located as desired.

**Note:** It is strongly recommended that covers be installed with the following minimum clearances. Skirts should have adequate clearance between the tank sump riser sidewall and or the sump top hat. A minimum of one and a half inches clearance on all sides is recommended between the skirt and the tank sump wall or the sump top hat wall. A minimum of two inches clearance is recommended between the bottom of the skirt and the horizontal surface of the tank sump or sump top hat. These clearances are recommended to allow adequate water migration away from the sumps. Great care should be used to maintain the recommended clearances when setting the rings and pouring the concrete.

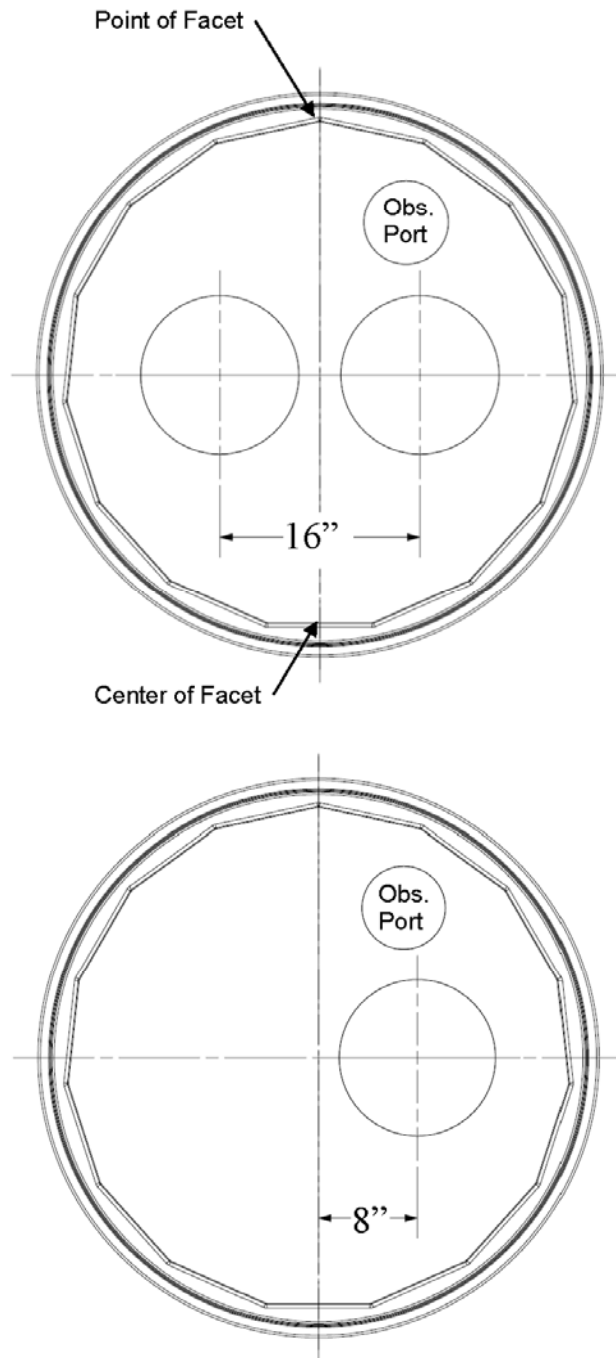


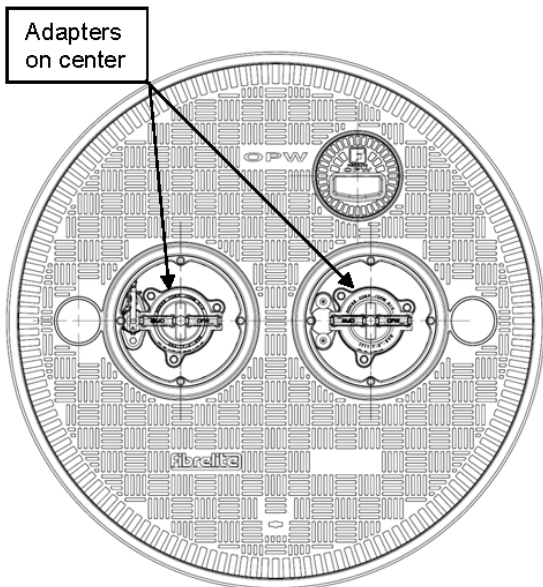
Figure 28

**For new and steel retrofit installations  
proceed to step 55 on page 20.**



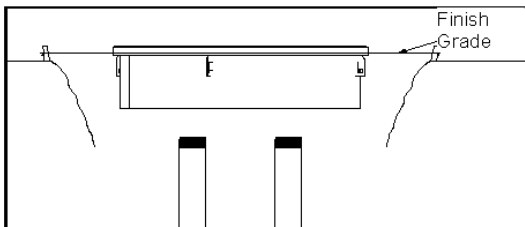
**Fibrelite Multiport Spill Container  
Installation Instructions for retrofit into existing  
composite frame**

- 49. Ensure diameter of existing cover to be retrofit matches new cover before proceeding.
- 50. Ensure existing adapters are on center with existing ports. Adapters should be within approximately 1" radially of port center. If adapters are too far off center a retrofit may not be possible (See Figure 29)



**Figure 29**

- 51. Measure distance from finish grade to the top of the riser pipes (or face seal adapters if present). Distance should be greater than or equal to 22 inches. Nominal distance from finish grade to top of riser for P761C-FLXX buckets is 23.5 inches. If not prepared to adjust riser pipe to necessary height do not continue.

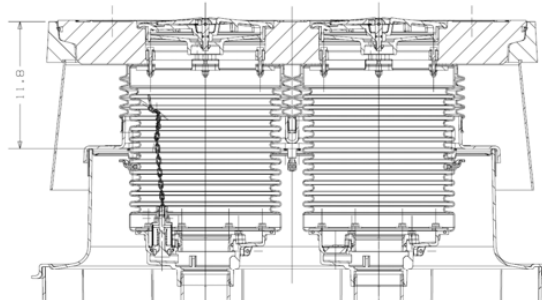


**Figure 30**

**Note:** For use of P7XX or P5XX buckets with adapter ring see Figure 53 in Appendix on page 26 for riser height dimensions.

- 52. Remove existing FL100 cover and measure the distance from the spill platform to the final grade. Distance should be 12" +/- 4" in order to retrofit. If distance does not meet this range it may not be possible to retrofit without making adjustments. See Figure 31.

**Note:** Ensure electrical connections and other equipment will not interfere with new spill buckets.



**Figure 31**

- 53. If desired, the existing drop tube / overflow valve can potentially be used with the retrofit installation. Determine mounting location of current drop tube / overflow valve (See Figure 32 and 33 for the two most common scenarios).

**Scenario #1 (Figure 32) -** If drop tube / overflow valve is mounted at the adapter (the drop tube / overflow valve can be used as is if the grade to adapter height is maintained. Measure existing grade to adapter height and maintain with new configuration. Confirm dimensions meet requirements in the drop tube / overflow valve instructions when reinstalling.

**Scenario #2 (Figure 33) -** If drop tube / overflow valve is mounted in the bottom of the spill container (on FSA face seal adapter) the valve will most likely need to be replaced to meet the dimension in the new configuration. The nominal dimension from grade to sealing face in base of new spill container is 23 inches. Install new drop tube / overflow valve per instructions supplied with drop tube / overflow valve.

**Note:** If drop tube / overflow valve were to be installed in Location C as shown in Figure 27 if the tee remains in same location the drop tube / overflow valve can be used as is.

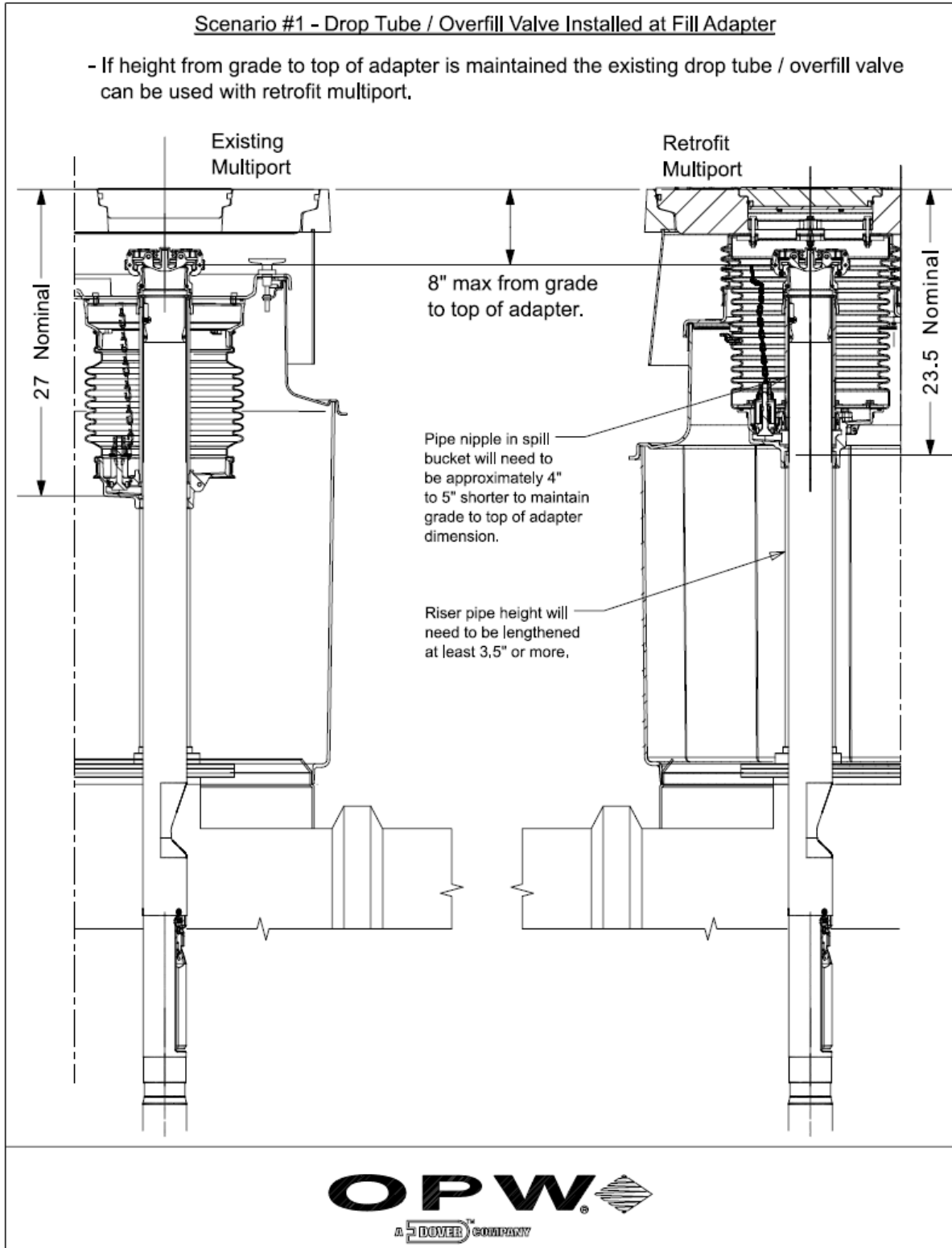
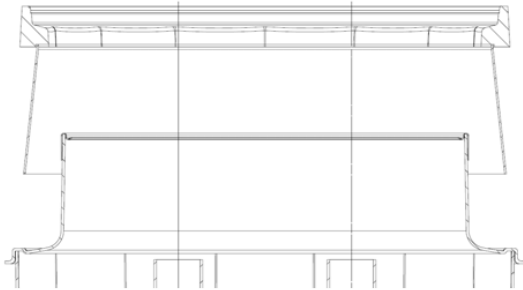


Figure 32



54. Remove spill platform from existing tank sump top hat. If present remove S-CS-SEALANT sealant between skirt and top hat. See Figure 34.



**Figure 34**

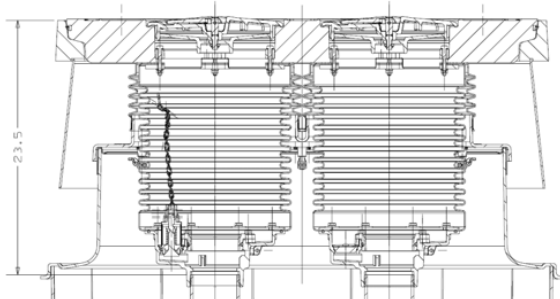
**Fibrelite Multiport Spill Container  
Installation Instructions**

- 55. Adjust the riser(s) from the underground tank so that both the fill and vapor risers are set below the final grade. Use the dimensions below:

Spill Container	Inches below top of multiport (L)
5 Gal. Cast Iron Base	23½"

**Note:** Add an extra 3-1/4" when using an OPW FSA-400 & add an extra 2" when using the FSA-400-S Face Seal Adaptor. (See Figure 35.) (Offset add extra 6")

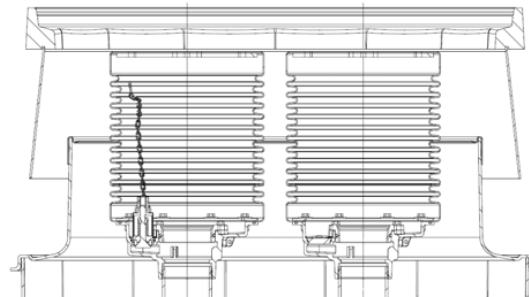
**Note:** For use of P7XX or P5XX buckets with adapter ring see Figure 53 in Appendix on page 26 for bucket dimensions.



**Figure 35**

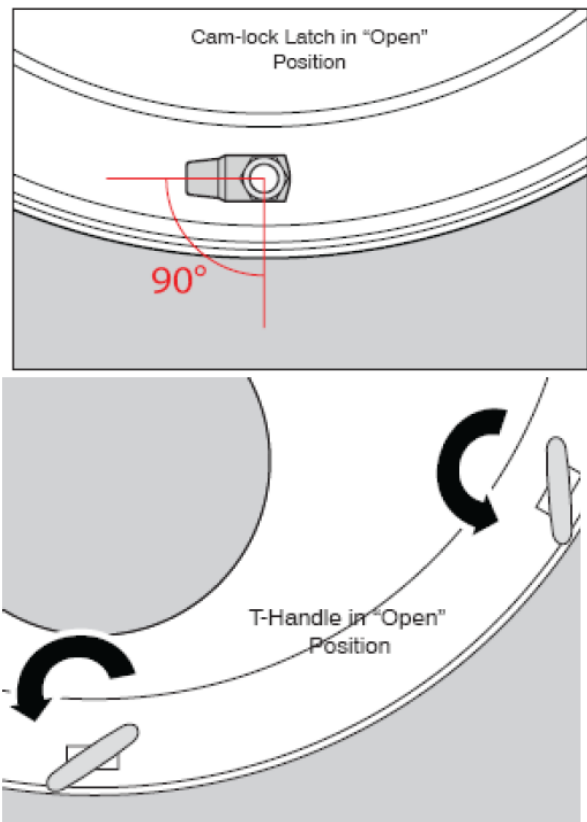
- 56. Deburr and thoroughly clean riser pipe(s).
- 57. Apply pipe dope to riser(s). The pipe dope is to be a non-hardening, gasoline resistant, pipe thread seal compound.
- 58. Thread on new P761C-FLXX spill containers. (P7XX or P5XX spill containers with adapter ring can also be used).
- 59. Using the 1-3100—TOOL (61SA-TOOL for P7XX or P5XX), tighten the spill container(s) onto the riser(s) with a minimum torque of 125 ft.-lbs. and a maximum torque of 250 ft.-lbs. See Figure 36.

**Note:** Ground riser pipe(s) to nearest grounding rod.

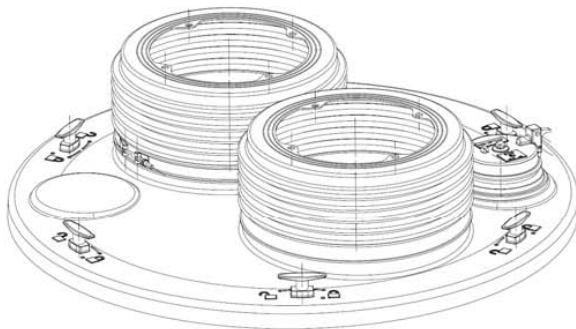


**Figure 36**

- 60. Ensure shroud cover is ready for installation. Turn all T-handles on the water shroud platforms to the open position – the cam-lock latches on the underside should be 90 degrees opposed from the edge of the platform (See Figure 37): Loosely install shroud boots over the shroud cover but do not tighten band clamps. Observation cover should be installed with all threaded openings plugged. See Figure 38.

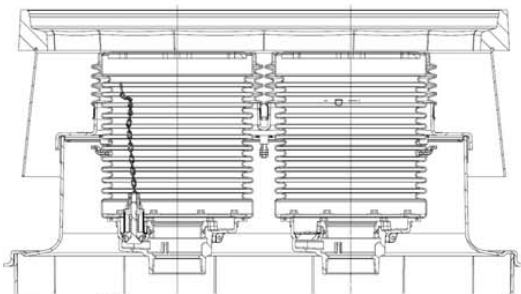


**Figure 37**



**Figure 38**

61. Install water shroud platform and boots over spill containers. See Figure 39.



**Figure 39**

62. Seat the water shroud platform on the stainless steel ring. Press down on the water shroud platform. Turn the T-handles 90 degrees to lock the latch beneath the stainless steel ring. See Figure 40.

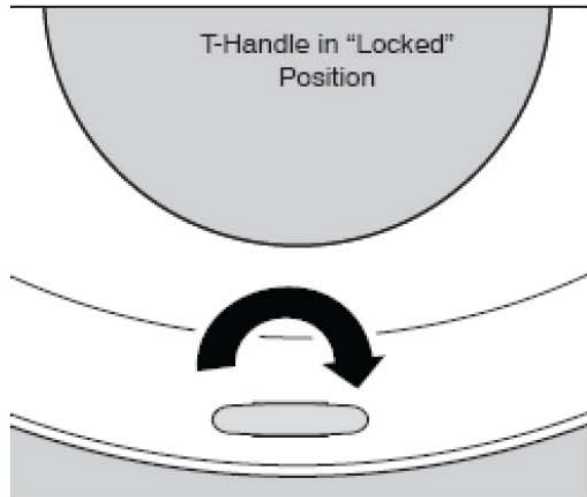
If the T-handle (See Figure 41) fails to engage it may be necessary to adjust the 'cam-lock' height.

If the T-handle is not fully engaging it means the cam-lock needs to be lowered. Loosen the base nut (see Figure 42) to a lower position. Pull the cam-lock down to rest onto the base nut (see Figure 43). Lower and tighten the fixing nut until the cam-lock is secure as shown in figure 45.

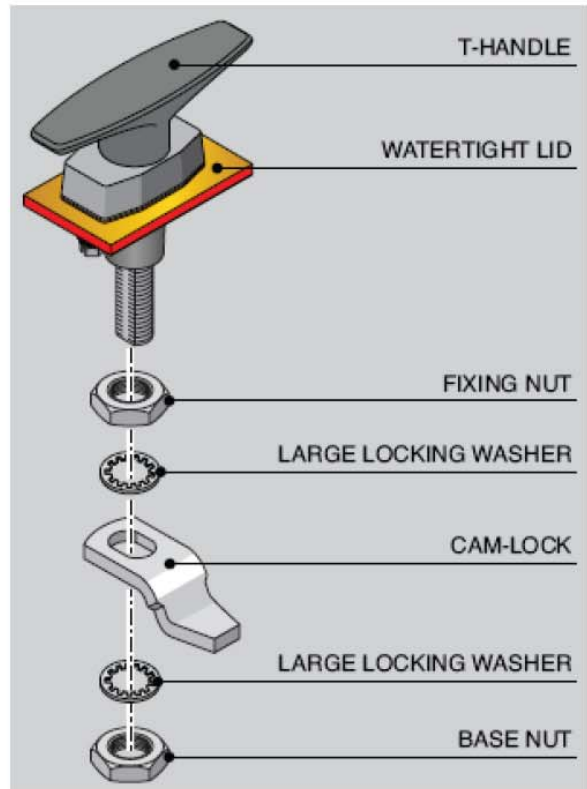
If the lid is not compressing the gasket tightly against the stainless steel ring it means the cam-lock needs to be raised. Loosen the base nut (see Figure 42) and pull the cam-lock down to rest onto the base nut and raise the fixing nut (see Figure 44). Push the cam-lock up to the fixing nut and tighten the base nut until the cam-lock is secure as shown in figure 45.

Once the cam-lock is secure refit the water shroud platform.

**Note:** It may be necessary to further adjust the cam-lock height until the optimal position is located.



**Figure 40**



**Figure 41**

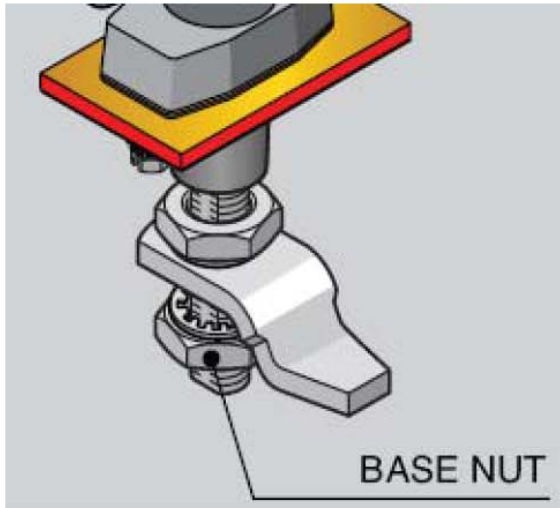


Figure 42

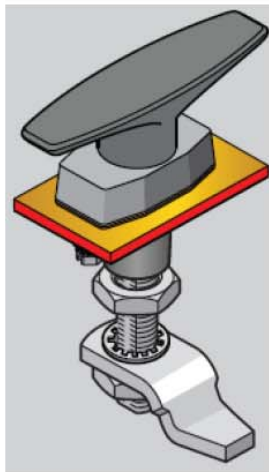


Figure 43



Figure 44

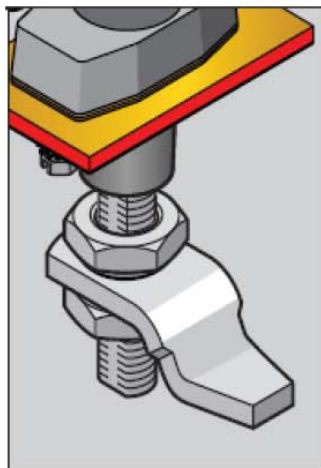


Figure 45

63. Align holes on shroud boots with holes in spill container upper ring and bellows. After aligning holes tighten shroud boot clamps to 60 in-lbs. See Figure 46.

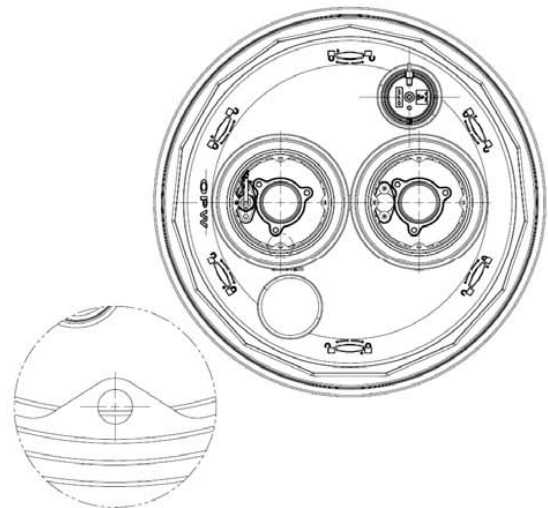


Figure 46

64. Install new FL100-MPS cover into FL100F frame. Ensure observation port in shroud cover and FL100-MPS cover are aligned.

65. Using 209398 rings attach upper ring of spill containers to 209398 rings using 5/16 bolts, washers, lock washers, and nuts. Tighten bolts and nuts to 15-20 in-lbs. See Figures 47 thru 49.

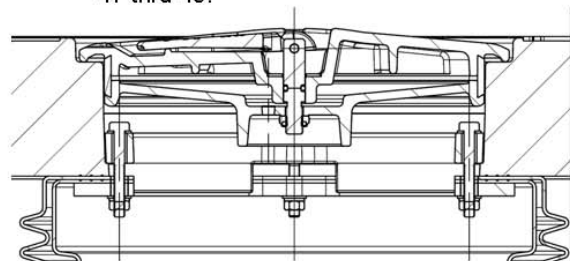


Figure 47



Figure 48

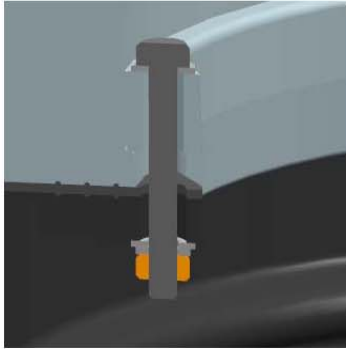


Figure 49

66. Install the spill bucket covers.

**For retrofit installations into an existing composite frame not requiring concrete proceed to step 71 on page 24.**

67. Confirm frame is still aligned properly as determined in step 47. Complete backfilling to appropriate level. Cover the frame and cover with plastic to prevent concrete from settling in the drainage areas.

68. It is required that the frame and skirt assembly, and the multiport cover be set as an assembled unit, with the bolts on the 209398 rings engaged. Frame must be supported by a minimum depth of 8" of concrete (maximum 13.75" depth, see Figure 50.) Concrete reinforcement must be positioned as close to the frame as possible. Minimum block of 20" square around the frame. Joint must be tied as per Figure 51. Continuous pour preferred if possible.

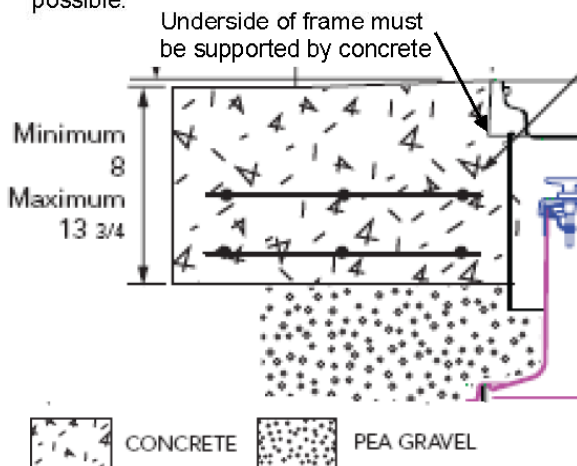


Figure 50

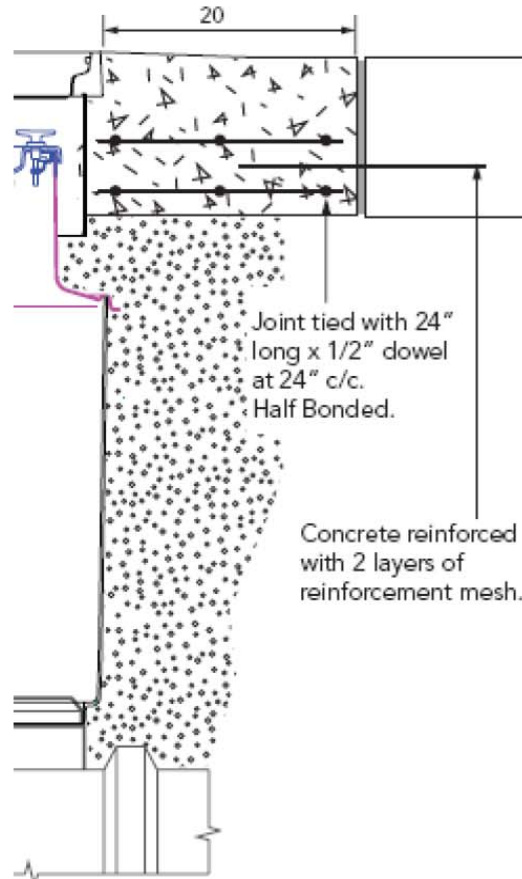


Figure 51

69. When pouring the concrete, hand shovel or trowel the concrete around the multiport assembly to prevent the unit from moving or shifting, which can cause alignment and future maintenance problems. Ensure the void between top hat and skirt is kept free from concrete.

**NOTE: Do not stand on the multiport before the concrete has set up.**

70. It is required that the paved contours around the covers be adequately sloped to direct water flow away from the cover, and directing water runoff from adjacent areas away from covers. Minimum slope is 1" from grade to the top of the ring of the manhole. Note that this slope must be taken into consideration when cutting riser lengths in earlier steps.



71. Install overfill valve, jack screw kits, pipe nipples, adapters, and caps into spill containers as specified in their installation instructions. Adapters must be no more than 8" from grade. Clearance between spill container cover and cap must be 1" minimum. Recommended dimensions are shown in Figure 52.

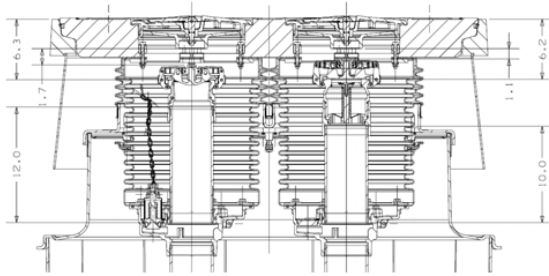


Figure 52

72. (Optional): Install the 1TAG product identification disc on the spill bucket cover and multi-port cover in the I.D. disc recess.
73. After installation is complete, water test the multi-port fixture. The recommended water test procedures include:
  - a) Spraying water on cover(s) for 5 to 10 minutes, using a commonly available watering device such as a lawn sprinkler.
  - b) Standing water test, not to exceed 1/2" in water depth for a period of 5 to 10 minutes.

If water is found on the interior of the spill container or on the skirt (which can be checked through the observation port) that is not due to condensation; determine the root cause of the leak, repair the seal, and retest the unit.

**74. Testing Spill Containers**

Use CARB TP201-1C or TP201-1D Test Procedures. These Test Procedures will check the seals between the drain valve, nipple and rotatable adapter.

To test the spill containers base and bellows fill the container with water. A drop in the water level of 1/8" or greater after one hour means that a leak exists. To determine where the leak is, look for a steady stream of bubbles coming from one of the joints or water leaking on the outside of the bucket.

**NOTE:** Do not drain the water into the UST after the test is complete. Water must be disposed of per local requirements for

hazardous waste. If the leak cannot be corrected the spill container should be replaced with another.

As an alternate to a hydrostatic test a vacuum test can be performed on the spill container. Using OPW DW-VAC-TEST and SC-TEST, perform a vacuum test on the spill container. An initial vacuum of 15" of water should be attained and the spill container must retain a vacuum of at least 12" of water after 5 minutes. (See DW-VAC-TEST Instructions.)

**Warning:**  
**If the cover is removed, for any reason, follow the Service and Maintenance instructions as noted. Always inspect and replace damaged seals and install new seals. Never reuse damaged seals as it may result in an improper seal.**

**Operation and Maintenance:**

After each fuel delivery, the operator must remove any standing fuel from the container. Fuel can be removed by actuating the drain valve or with a gasoline absorbing disposable towel. If access to drop tube or overfill valve is required remove Nipple Adaptor from primary bucket.

**Weekly:** Perform a visual inspection of the interior of the containment bucket for water or other contaminants. If water or other contaminants are found they must be disposed of with disposable towels. Dispose of towels safely and per all applicable local, state and federal codes. Check that cover is in good condition and properly identified. Replace cover and seal as necessary. Inspect the bucket walls for cracks, bulges or holes. If any exist, have that spill container barricaded and contact maintenance personnel immediately for repairs.

**NOTE: The bellows and base on the spill container can be replaced if damaged.**

**Semiannually:** Follow all state and local required hydrostatic or vacuum testing on the buckets. Inspect and clean the interior of the spill container and drain valve screen. Remove accumulated dirt and grit. Where applicable, test the drain valve using CARB procedure TP-201.1C or TP-201.1D. If the drain valve passes testing no further maintenance is required. If the drain valve fails testing, remove the valve, soak in water and use high-pressure air, if needed, to clean. Reinstall the drain valve to its proper position and where applicable, test the valve with CARB procedure TP-

201.1C or TP-201.1D. If problems persist, replace the drain valve with P/N 1DK-2100-EVR (specified torque 11.5 ft-lbs min to 13.5 ft-lbs max, 5/16-18 UN thread). The sealable cover (1SC) adjustment nut is set at the factory, but due to environmental conditions it may be necessary to adjust it to either improve sealing or ease cover removal.

OPW recommends periodic inspection of covers and seals as a part of the regularly scheduled maintenance program. If any of the seals are damaged they should be replaced. Only qualified, competent, well-trained technicians should perform maintenance.

Note: Common sense and good judgment should always be exercised. The contractor's understanding of all related site conditions prior to starting the project is essential. If the contractor does not have a clear understanding of the required work and site conditions, the contractor is advised to seek clarification prior to starting any portion of the project.

**Important: Leave these instructions with Station Operator**



9393 Princeton-Glendale Rd.\* Hamilton, Ohio 45011  
 1-800-422-2525 Domestically, 513-870-3315 Internationally  
 Copyright, 2015 - OPW Fueling Components Inc., Cincinnati, OH  
 Printed in U.S.A. p/n 210271 – Rev. A5 12/14/15

**Appendix – P7XX or P5XX Bucket with Adapter Ring Installation Only**

Riser Height dimensions for use of P7XX or P5XX Buckets with Adapter Ring.

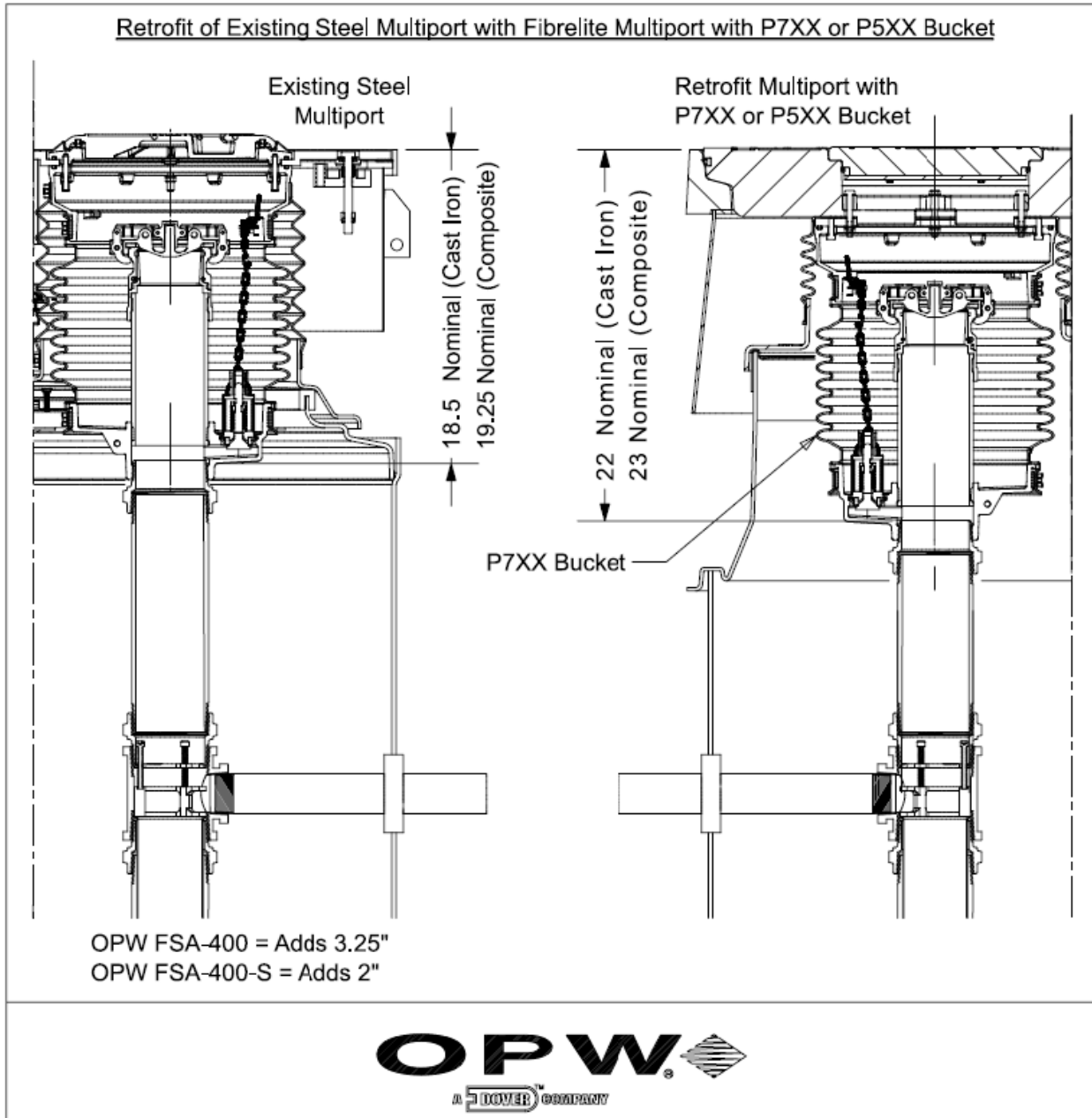


Figure 53

**Appendix (continued) – P7XX or P5XX Bucket with Adapter Ring Installation Only**

Before installing P7XX or P5XX bucket attach adapter ring to bucket. Attach adapter ring 210641-KIT to P7XX or P5XX Buckets as shown in Figure 54. Ensure lockwasher and flat washer are installed on the bolt. Tighten the four supplied 5/16-18 bolts to 15 ft-lbs minimum to 20 ft-lbs maximum.

Note: Bolt must not protrude thru adapter ring.

Note: Top of adapter ring is a sealing surface. Keep surface as clean as possible.

With adapter ring installed the buckets will attach in the same manner as depicted in step 65 with the adapter ring acting as the upper ring of the spill container.

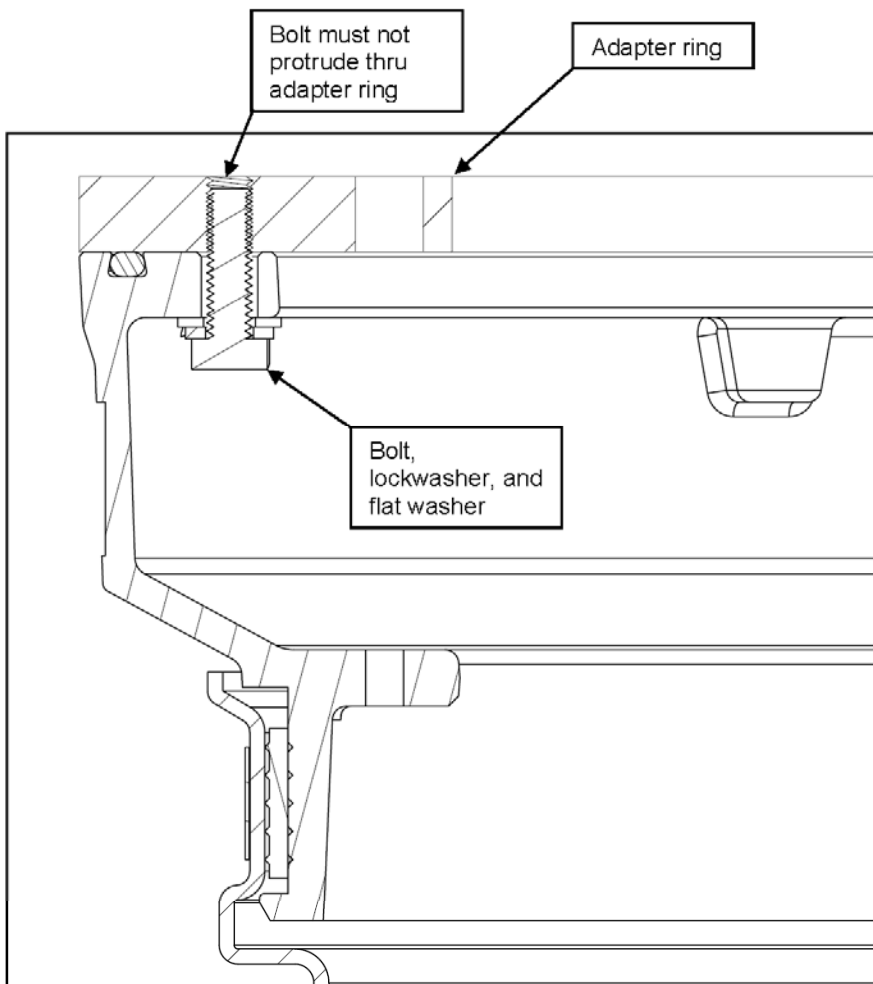


Figure 54



## Installation and Maintenance Instructions OPW 6111-1400 Tank Bottom Protectors

**IMPORTANT:** Please read these warnings and assembly instructions completely and carefully before starting. Failure to do so may cause product failure, or result in environmental contamination due to liquid leakage into the soil, creating hazardous spill conditions.

**IMPORTANT:** The OPW Tank Bottom Protector is pre-assembled for your convenience and ease of installation. Check to make sure the unit is intact and undamaged and all parts have been supplied. Never substitute parts for those supplied. Doing so may cause product failure.

**WARNING-DANGER:** Using electrically operated equipment near gasoline or gasoline vapors may result in a fire or explosion, causing personal injury and property damage. Be sure that the working area is free from such hazards, and always use proper precautions.

**NOTE:** At all times when product is in the storage tank keep the riser pipe capped, so the vapors cannot escape into the environment.

**Notice:** OPW products must be used in compliance with applicable federal, state, and local laws and regulations. Product selection should be based on physical specifications and limitations and compatibility with the environment and material to be handled. All illustrations and specifications in this literature are based on the latest production information available at the time of publication. Prices, materials, and specification are subject to change at any time, and models may be discontinued at any time, in either case, without notice or obligation.

Notice: Flex- WorksbyOPW, Inc., VAPORSAVER™ and all other OPW products must be used in compliance with all applicable federal, state, provincial and local laws, rules and regulations. Product selection is the sole responsibility of the customer and/or its agents and must be based on physical specifications and limitations, compatibility with the environment and material to be handled. All illustrations and specifications in this literature are based on the latest production information available at the time of publication. Prices, materials and specifications are subject to change at any time, and models

This section intentionally left blank.

**Tank Bottom Protector:**

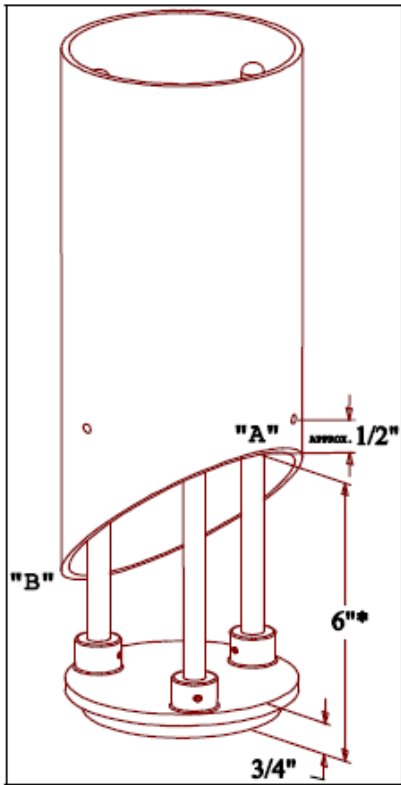
The OPW Tank Bottom Protector is designed to protect the Underground Storage Tank from damage due to the tank measuring stick being dropped into the tank to measure the fluid level.

**OPW TANK BOTTOM INSTALLATION  
INSTRUCTIONS**

1. Check the distance from the bottom of the fill tube to the bottom of the tank. Verify that this distance is in conformance with manufacturer's recommendations and Local Codes. Remove the drop tube from the tank.
2. Using a # 11 Drill (0.191") - Drill a hole into the fill tube about 1/2" above and 1" to 1 1/16" over from point "A" (see figures 1 and 2). Keep in mind that the OPW Tank Bottom Protector must rest on the bottom of the tank.
3. Insert the OPW Tank Bottom Protector and line up the # 11 hole in the sliding rod guide with the corresponding hole just drilled in the drop tube. Make sure that point "A" is clear for future measurements of the drop tube's length. (See figure 2).
4. Attach the OPW Tank Bottom Protector with the pop rivet supplied. Drill two more # 11 holes into the drop tube and sliding rod guide at the same time. Install supplied pop rivets into new holes.
5. Check to ensure that the OPW Tank Bottom Protector slides up and down without binding.
6. Reinstall fill tube into the tank.

*\*Check local codes and regulation for proper dimension.*

This section intentionally left blank.



This section intentionally left blank.

Figure 1

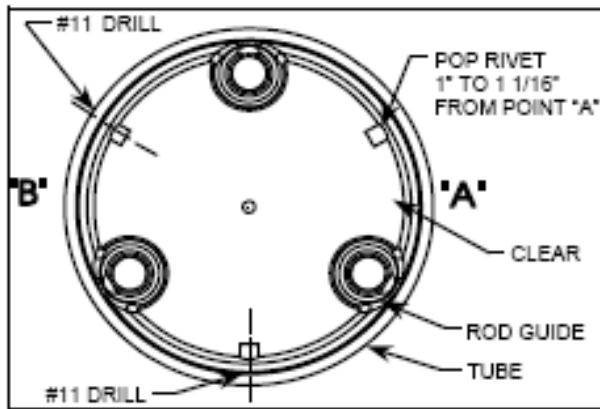


Figure 2



3250 US 70 Business West  
Smithfield, NC 27577  
Customer Service: 1-(800) 422-2525  
Technical Service and Questions:  
1-(877) OPW-TECH  
[www.opwglobal.com](http://www.opwglobal.com)



## OPW 723V Pressure / Vacuum Vent Valve Installation and Maintenance Instructions

Please read these warnings and assembly instructions completely and carefully before starting. Failure to do so may cause product failure, or result in environmental contamination due to liquid leakage into the soil, creating hazardous spill conditions.

**IMPORTANT:** The OPW 723V Pressure/Vacuum vent is preassembled for your convenience and ease of installation. Check to make sure the unit is intact and undamaged and all parts have been supplied. Never substitute parts for those supplied. Doing so may cause product failure.

**WARNING-DANGER:** Using electrically operated equipment near gasoline or gasoline vapors may result in a fire or explosion, causing personal injury and property damage. Be sure that the working area is free from such hazards, and always use proper precautions.

**Notice:** OPW products must be used in compliance with applicable federal, state, and local laws and regulations. Product selection should be based on physical specifications and limitations and compatibility with the environment and material to be handled. All illustrations and specifications in this literature are based on the latest production information available at the time of publication. Prices, materials, and specification are subject to change at any time, and models may be discontinued at any time, in either case, without notice or obligation.

### OPW STANDARD PRODUCT WARRANTY TAG

Notice: FlexWorks by OPW, Inc., VAPORSAVER™ and all other OPW products must be used in compliance with all applicable federal, state, provincial and local laws, rules and regulations. Product selection is the sole responsibility of the customer and/or its agents and must be based on physical specifications and limitations, compatibility with the environment and material to be handled. All illustrations and specifications in this literature are based on the latest production information available at the time of publication. Prices, materials and specifications are subject to change at any time, and models may be discontinued at any time, in either case, without notice or obligation.

OPW warrants solely to its customer (the initial purchaser and any subsequent purchasers within the warranty period) that the following products sold by OPW will be free from defects in materials and workmanship under normal use and conditions for the periods indicated:

PRODUCT	WARRANTY PERIOD
FlexWorks Primary Pipe	10 years from date of manufacture
All Products and replacement parts installed in the State of California Certified to California CP-201 and/or CP-206 Standards*	1 year from date of installation (proof of purchase from certified contractors/technicians required) OPW warrants ongoing compliance with the standards and specifications for the duration of the warranty period required by the State of California; this limited warranty is under the condition the equipment was installed and maintained by trained and certified contractors/technicians unless noted in Installation Manual.
All other Products and replacement parts	1 year from date of manufacture**
*Products certified to California CP-201 and/or CP-206 Standards have been factory tested and met all applicable performance standards and specifications and will have an OPW registration card enclosed/attached to the product.	

OPW's exclusive obligation under this limited warranty is, at its option, to repair, replace or issue credit (in an amount not to exceed the list price for the product) for future orders for any product that may prove defective within the applicable warranty period. (Parts repaired or replaced under warranty are subject to prorated warranty coverage for remainder of the original warranty period). Complete and proper warranty claim documentation and proof of purchase required. All warranty claims must be made in writing and delivered during the applicable warranty period to OPW at OPW 9393 Princeton-Glendale Road Hamilton, Ohio, USA 45011, Attention: Customer Service Manager. No products may be returned to OPW without its prior written authority.

This limited warranty shall not apply to any FlexWorks or VAPORSAVER™ product unless it is installed by an OPW attested installer and all required site and warranty registration forms are completed and received by OPW within 60 days of installation. This limited warranty also shall not apply to any FlexWorks, VAPORSAVER™ or other OPW product: unless all piping connections are installed with a nationally-recognized or state-approved leak detection device in each tank and dispenser sump (which are not for storage and from which all discharge hydrocarbons must be removed, and the systems completely cleaned, within 24 hours); unless testable sumps utilize FlexWorks pipe and access fittings; unless a sump inspection log or an EPA recommended/required checklist is maintained and the results are furnished to OPW upon request; and unless OPW is notified within 24 hours of any known or suspected product failure and is provided with un-



restricted access to the product and the site. This limited warranty also shall not apply to any product which has been altered in any way, which has been repaired by anyone other than a service representative authorized by OPW, or when failure or defect is due to: improper installation or maintenance (including, without limitation, failure to follow Flex-Works Quick Reference Manual Installation Guide and all product warning labels); abuse or misuse; violation of health or safety requirements; use of another manufacturer's, or otherwise unauthorized, substances or components; soil or other surface or subsurface conditions; or fire, flood, storm, lightning, earthquake, accident or any other conditions, events or circumstances beyond OPW's control.

THIS LIMITED WARRANTY IS IN LIEU OF ALL OTHER WARRANTIES, EXPRESS OR IMPLIED, AND ALL OTHER WARRANTIES INCLUDING, WITHOUT LIMITATION, THE WARRANTIES OF MERCHANTABILITY AND FITNESS FOR A PARTICULAR PURPOSE, ARE HEREBY EXCLUDED.

OPW shall have no other liability whatsoever, whether based on breach of contract, negligence, gross negligence, strict liability or any other claim, including, without limitation, for special, incidental, consequential or exemplary damages or for the cost of labor, freight, excavation, clean-up, downtime, removal, reinstallation, loss of profit, or any other cost or charges. No person or entity is authorized to assume on behalf of OPW any liability beyond this limited warranty. This limited warranty is not assignable.

**\*\* Date of manufacture on this product is located on the top of the Valve.**

**OPW 723V Series Performance Specifications:**

This Pressure / Vacuum vent has been manufactured and tested to the following specifications: Pressure leak rate not to exceed 0.05 CFH at 2" W.C. Vacuum leak rate not to exceed 0.21 CFH at -4" W.C. The cracking pressure to be 2.5" to 6" W.C. and cracking vacuum to be -6" to -10" W.C. Tested using CARB Test Procedure TP-201.1E, TP-201.1E CERT, or applicable Phase I Executive Order.

Install vent per requirements in NFPA 30. Vents should be located so that vapors will not be trapped by eaves or other obstructions.

**Torque Specification:**

Vent Assembly 2" NPT, 35 ft-lbs minimum to 55 ft-lbs maximum.

**OPW 723V PRESSURE / VACUUM VENT VALVE INSTALLATION INSTRUCTIONS:**

**Step 1:**

Deburr and thoroughly clean vent pipe. **NOTE: Vent must be mounted vertically.** Apply pipe dope to vent pipe threads. Pipe dope to be a non-hardening, gasoline resistant pipe thread seal compound.

**Step 2:** (See Figure 1)

Screw the vent assembly onto the vent pipe and torque to 35 ft.-lbs minimum to 55 ft.-lbs maximum. Use the flats on the

pipe adaptor only, **Do not wrench on the composite valve assembly.**

**NOTE: NEVER PAINT OR COVER THE VENT**

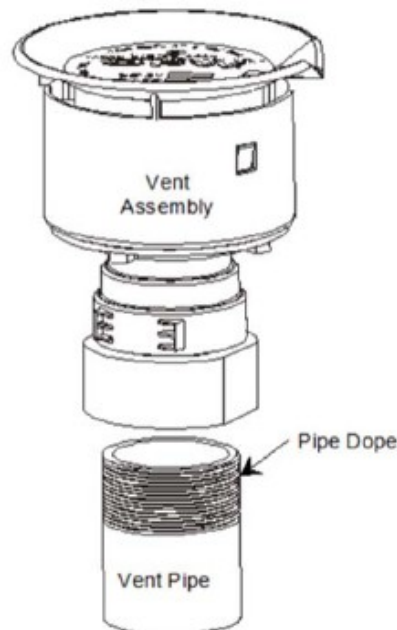


Figure 1

**Operation and Maintenance:**

Annual maintenance is required to keep the vent operating satisfactorily. Remove and inspect filter screens – clean or replace as necessary. Test as necessary.

**Upper Screen Maintenance**

1. Remove vent top by depressing tabs as indicated in Fig. 2, and lift top upward. Screen will slip up and out of valve.
2. Clean or replace filter screen (P/N 209817 for 723V) as necessary and reinstall Fig. 3.
3. Reinstall vent top by reinserting into the body. Be sure the tabs are inside the valve body, and then rotate top until the tabs snap into place.

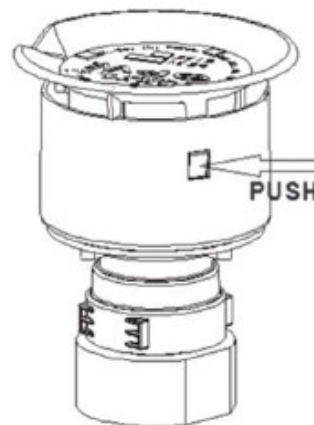
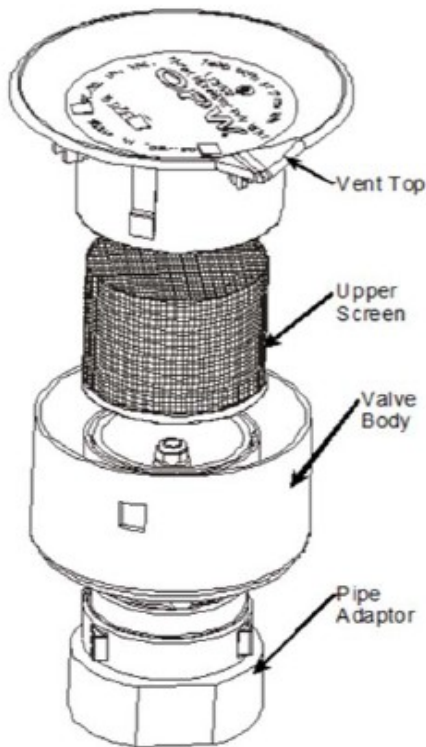
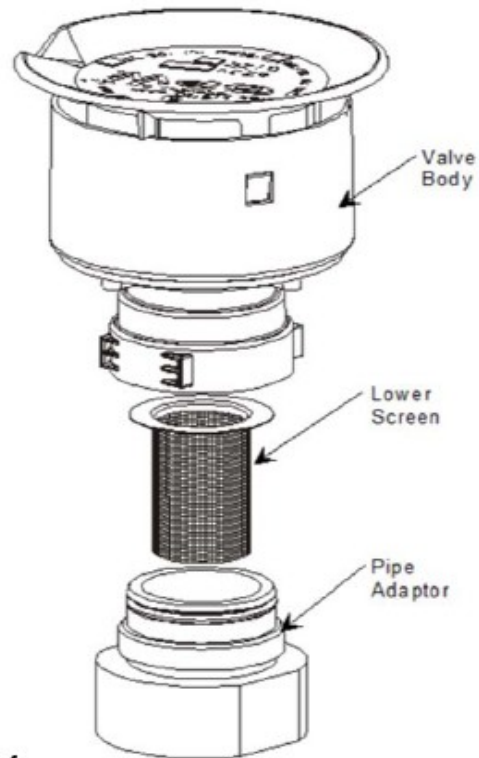


Figure 2



Manufacture Date "MM / YY"  
MM = Month, YY = Year

**Product Identification**



**Lower Screen Maintenance**

**Note:** Do not remove the pipe adaptor from the vent pipe to service the lower filter screen.

1. Remove valve assembly from the pipe adaptor. Grip assembly at the flats just above the pipe adaptor and unscrew. (Fig. 4)
2. Lift the filter screen out and clean or replace (P/N C05086M) as necessary.
3. Reinstall filter screen in the pipe adaptor (see Fig. 4 for orientation).
4. Reinstall valve assembly on pipe adaptor and tighten until it stops. Do not wrench valve assembly except with smooth jaw wrench.

**Valve Testing**

If any issues are seen when testing using CARB Test Procedure TP-201.1E it is recommended to retest the valve using CARB Test Procedure TP-201.1E CERT. Ensure valve is mounted vertically.

**IMPORTANT: Leave these instructions with Station Operator.**

Figure 4




**OPW Retail Fueling**  
3250 US 70 Business West  
Smithfield, NC 27577  
Customer Service: 1-(800) 422-2525  
Technical Service and Questions:  
1-(877) OPW-TECH  
[www.opwglobal.com](http://www.opwglobal.com)


Part Number: 211278  
Issue Date: 03-01-2018

Notice: OPW products must be used in compliance with applicable federal, state, provincial and local laws and regulations. Product selection should be based on physical specifications and limitations and compatibility with the environment and material to be handled. OPW makes no warranty of fitness for a particular use. All illustrations and specifications in this literature are based on the latest production information available at the time of publication. Prices, materials and specifications are subject to change at any time, and models may be discontinued at any time, in either case, without notice or obligation. For complete OPW warranty information, visit our web site at [www.opwglobal.com](http://www.opwglobal.com).

## Husky Model 5885 Pressure/Vacuum Vent Valve

	MODEL #5885 Recommended Installation, Maintenance and Inspection Instructions	<b>5885</b>
	<b>EVR Pressure Vacuum Vent</b>	

IMPORTANT SAFETY INSTRUCTIONS - SAVE THESE INSTRUCTIONS IN A READILY ACCESSIBLE LOCATION.

 **WARNING** Designed for use at motor fuel dispensing facilities only.

### INSTALLATION INSTRUCTIONS

NOTE: Always adhere to installation / usage instructions and warnings. Improper use may result in injury, damage or hazardous spill.

1. Remove the vent from the carton and visually inspect for any shipping damage.
2. Apply fuel resistant pipe sealant to the threads on the 2" / 50.8 mm vent stack.
3. Screw the Pressure Vacuum (P/V) vent onto the vent stack and tighten firmly, approximately 20 - 50 lbf·ft / 27.1 - 67.8 N·m, but do not overtighten.

**CAUTION: DO NOT ALTER OR COVER THE P/V VENT**

### TESTING / MAINTENANCE / INSPECTION

Testing Criteria Per TP201.1E and Exhibit 3 of applicable Phase 1 E.O.

Leak rate: Pressure = .05 CFH @ 2" wc, Vacuum = .21 CFH @ -4" wc.  
Cracking Pressure = 2 1/2" to 6" wc, Vacuum = -6" to -10" wc.



*Annually Inspect the P/V vent valve for foreign objects:*

1. Remove the screws that hold on the top cover. Do not remove the screens.
2. Remove any debris from inside the lower cover.
3. Check the drain holes in the lower cover.
4. Reinstall the top cover.
5. Tighten the screws firmly.

- All drive aways, maintenance and inspection activities must be logged using the serial number of the individual product.
- Apply city, state, or federal testing regulations as appropriate.

**ANY TEST / INSPECTION FAILURE REQUIRES IMMEDIATE EQUIPMENT REPLACEMENT OR REMOVAL FROM SERVICE.**

**MADE IN THE USA**

**⚠ ALWAYS ADHERE TO INSTALLATION / USAGE INSTRUCTIONS AND WARNINGS. ⚠**  
 Improper use may result in injury, damage, or hazardous spill.

**⚠ GENERAL WARNINGS / INSTRUCTIONS PERTAINING TO A RISK OF FIRE, ELECTRIC SHOCK OR INJURY TO PERSONS:**

- Use of equipment is at individuals' own risk.
- Always abide and adhere to city, state, and federal regulations regarding use and installation of dispensing equipment.
- Always follow the dispenser manufacturer's instructions.
- Always turn off all power to dispenser during maintenance and inspection activities.
- Always close the shear valves during maintenance and inspection activities.
- Always relieve pressure from system prior to performing maintenance activities.
- Always check continuity after installation using a megohmmeter (Refer to PEI RP 400 for details).
- Always replace or remove from service damaged or leaking dispensing equipment immediately.
- Always report leaks / spills / accidents to appropriate authorities.
- Always wear appropriate safety equipment during maintenance activities.
- Always have appropriate fire extinguishing equipment within 5 ft / 1.5 m of dispensers.
- Always use pipe sealant approved for gasoline service.

- Always place containers on the ground before filling.
- Always discharge static electricity before using or servicing equipment by touching a metal part of the dispenser before and after fueling vehicle.
- Never smoke within 20 ft / 6.1 m of dispensers.
- Never keep in service past recommended life.
- Never leave the nozzle unattended while dispensing fuel.
- Never use sparking or flaming devices within 20 ft / 6.1 m of dispensers.
- Never use power tools near dispensers or to aid in the installation process.
- Never use cell phone within 20 ft / 6.1 m of dispensers.
- Never reenter car when fueling vehicle.
- Never allow gasoline to touch eyes or skin.
- Never use at flow rates in excess of regulatory guidelines.
- Never use at flow rates less than 5 gpm / 18.9 Lpm.
- Never dispense flammable material into unapproved containers.
- Never dispense fuel without a valid driver's license.

**CAUTION: DO NOT ALTER OR COVER THE P/V VENT.**

**DO NOT OVERTIGHTEN.**

IMPORTANT SAFETY INSTRUCTIONS - SAVE THESE INSTRUCTIONS IN A READILY ACCESSIBLE LOCATION.

## WARRANTY

**VAPOR PRODUCTS** – Husky Corporation will, at its option, repair, replace, or credit the purchase price of any Husky manufactured product which proves upon examination by Husky, to be defective in material and/or workmanship for a period of one (1) year of installation or fifteen (15) months from the manufacture date of shipment by Husky, whichever occurs first. The warranty period on repaired or replacement vapor recovery products is only for the remainder of the warranty period of the defective product.

**EVR PRODUCTS** – With respect to EVR products installed in California, for a period of one (1) year from the date of installation, Husky warrants that the product will be free from defects in materials and workmanship (if the installation date is in question or indeterminable, Husky will warrant the product for 12 months from sale by Husky). Husky confirms that the warranty is transferable to a subsequent purchaser within the warranty period. However, the warranty does not follow the product from its initial installation location to succeeding locations. Husky confirms these products are warranted to meet the performance standards and specifications to which it was certified by CARB for the duration of the warranty. EVR products must be installed per CARB Executive Order and must follow the Husky Installation Instructions or the warranty is void. The warranty tag included with the EVR product must be provided to the end user at installation. A completed warranty tag and installation documentation is required to be returned with the product to be eligible for warranty consideration.

**CONVENTIONAL PRODUCTS** – Husky Corporation will, at its option, repair, replace, or credit the purchase price of any Husky manufactured product which proves upon examination by Husky, to be defective in material and/or workmanship for a period of one (1) year from the manufacture date of shipment by Husky.

Buyer must return the products to Husky, transportation charges prepaid. This Warranty excludes the replaceable bellows, bellows spring assembly, spout assembly and scuff guard, unless (i) damage is obvious when the product is removed from shipping carton and (ii) the defective product is returned to Husky prior to use. This warranty does not apply to equipment or parts which have been installed improperly, damaged by misuse, improper operation or maintenance, or which are altered or repaired in any way.

The warranty provisions contained herein apply only to original purchasers who use the equipment for commercial or industrial purposes. There are no other warranties of merchantability, fitness for a particular purpose, or otherwise, and any other such warranties are hereby specifically disclaimed.

Husky assumes no liability for labor charges or other costs incurred by Buyer incidental to the service, adjustment, repair, return, removal or replacement of products. Husky assumes no liability for any incidental, consequential, or other damages under any warranty, express or implied, and all such liability is hereby expressly excluded.

Husky reserves the right to change or improve the design of any Husky fuel dispensing equipment without assuming any obligations to modify any fuel dispensing equipment previously manufactured.

**3" to 2" ADAPTOR INSTALLATION INSTRUCTIONS**

**Part #5041**

1. Visually inspect the o-ring and threads for chips, dirt & debris.
2. Apply fuel resistant pipe sealant to the 3 in / 76.2 mm NPTF threads of the vent pipe.
3. Screw the P/V vent adaptor onto the vent stack and tighten firmly, approximately 20 - 50 lbf·ft / 27.1 - 67.8 N·m, but do not overtighten.
4. Install the P/V vent according to manufacturer's installation instructions.

**TEST ADAPTOR INSTALLATION INSTRUCTIONS**

**Part #5426**

NOTE: This adaptor is designed to fit on the inlet of the P/V Vent to allow for field and lab tests.

1. Screw P/V Vent adaptor into the P/V Vent valve until hand tight. Make sure the seal is compressed.
2. Place the P/V Vent valve and adaptor on a flat surface.
3. Attach a 3/16" / 4.7 mm hose (Tygon fuel tubing) from test apparatus to hose barb on the side of the adaptor.
4. After testing, remove hose from barb and remove adaptor from vent.

**TROUBLESHOOTING GUIDE**

- |                                |                                                    |
|--------------------------------|----------------------------------------------------|
| Pressure Decay Test Failure... | 1. Test vent to CARB TP201.1E.<br>2. Replace vent. |
|--------------------------------|----------------------------------------------------|

For stations with ISD monitoring

- |               |                                                                                                  |
|---------------|--------------------------------------------------------------------------------------------------|
| Vapor leak... | 1. Verify other equipment is not the cause.<br>2. Test vent to CARB TP201.1E<br>3. Replace vent. |
|---------------|--------------------------------------------------------------------------------------------------|

- |                                               |                 |
|-----------------------------------------------|-----------------|
| Exceeds allowable system cracking pressure... | 1. Replace vent |
|-----------------------------------------------|-----------------|

**GENERAL TECHNICAL DATA**

Fuel Type	Test and warranty for gasoline and diesel fuel
Body	Sand cast aluminum
Screens	Stainless Steel 40 mesh
Seal	Nitrile Foam
Covers	Aluminum
Weight	1.2 lbs / 0.5 kg
Threads	2 in / 50.8 mm NPTF
Case Quantity	20

Listings




CARB EVR Executive Order Numbers: VR-101, VR-102, VR-103, VR-104, VR-105, VR-401-B, VR-402-A, VR-301, VR-302


**FFS Model PV-Zero Pressure/Vacuum Vent Valve**




***PV-ZERO***<sup>TM</sup>  
**Liquid-Filled Pressure/Vacuum Vent Valve**  
*FFS P/N 407215901*


**Installation, Testing  
and Maintenance Manual**


**Warning**  This symbol identifies a warning. A warning sign will appear in the text of this document when a potentially hazardous situation may arise if the instructions that follow are not adhered to closely. A potentially hazardous situation may involve the possibility of severe bodily harm or even death.


**Caution**  This is a caution symbol. A caution sign will appear in the text of this document when a potentially hazardous environmental situation may arise if the instructions that follow are not adhered to closely. A potentially hazardous environmental situation may involve the leakage of fuel from equipment that could severely harm the environment.

**Danger**  This symbol identifies an electrical danger. An electrical danger sign will appear in the text of this document when a potentially hazardous situation involving large amounts of electricity may arise if the instructions that follow are not adhered to closely. A potentially hazardous situation may involve the possibility of electrocution, severe bodily harm, or even death.

---

**Warning**  Follow all federal, state and local laws governing the installation of this product and its associated systems. When no other regulations apply, follow NFPA codes 30, 30A and 70 from the National Fire Protection Association. Failure to follow these codes could result in severe injury, death, serious property damage and/or environmental contamination.

**Warning**  Always secure the work area from moving vehicles. To help eliminate unsafe conditions, secure the area by using a service truck to block access to the work environment, or by using any other reasonable means available to ensure the safety of service personnel.

**Warning**  The PV-ZERO is used with tanks containing gasoline or other flammable substances, you may create an explosion hazard if you do not follow the requirements in this manual carefully.



**Description of the FFS PV-ZERO Liquid Filled P/V Vent Valve**

The PV-ZERO operates using a similar concept to a common P-Trap used in plumbing drain applications to create a liquid air seal. The liquid seals the UST ullage vapors from the atmosphere while still maintaining the proper differential pressure set-points. After the differential pressure has been exceeded, air or vapor bubbles through the liquid media until the pressure returns to the operational pressure settings. Figures 1-3 illustrate the operation of the PV-ZERO.

The PV-ZERO has no moving parts and the only maintenance required is periodic inspection of the liquid.

Because the PV-ZERO does not use seals or gaskets to seal off the UST ullage from atmosphere, the unit will not allow vapor or air to pass through at pressure less than the cracking set-point. As long as the valve is filled with 1.6 liters (54 ozs) of PV-ZERO fluid, the stainless steel valve housing is not damaged, and the pipe fittings are correctly installed, the unit should be leak free.

The liquid used for the PV-ZERO unit is silicone-based and has an very low vapor pressure and low toxicity.

The PV-ZERO can be mounted either at the top of the vent rack or in-line (mid-mount at working level). To avoid the risk of climbing a ladder and to maximize the simplicity of inspection and service, the preferred installation of the PV-ZERO is to be mounted in-line. It can be mounted on a single riser pipe or many riser pipes manifolded to a single line. The PV-ZERO is designed to mount on 3" riser piping, but can also be installed on 2" riser piping.

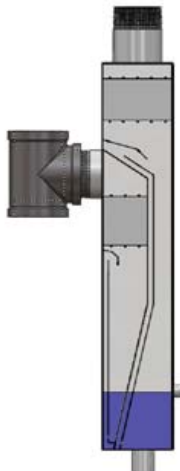
See drawings on pages 9-11 for mounting options.

\*\*\* Refer to CARB EVR documents regarding equipment rules for manifold systems.\*\*\*

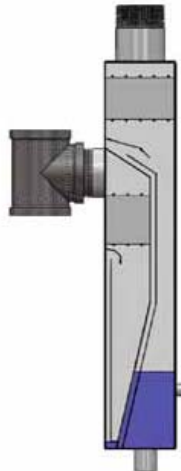
A support frame should be used for mounting all vent riser piping and must be used to stabilize the piping above the PV-ZERO if it is to be mounted in-line.

If the PV-ZERO is to be top mounted, the support frame must stabilize the piping below the unit (and the unit itself). Check local agencies for support frame requirements and consult a licensed structural engineer if in doubt of the structural integrity of the vent rack support system.

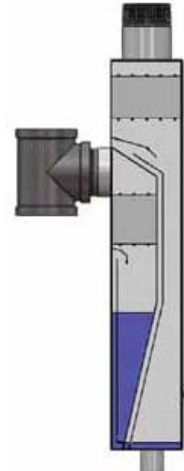
**Note:** Do not mount the PV-ZERO unit on a free standing vent piping system without a support frame!



**Figure 1: No Differential**



**Figure 2: Positive Cracking**



**Figure 3: Negative Cracking**

## Installation

**Note:** Use a thread sealant that is approved for gasoline and gasoline-ethanol blends such as Gasoila Soft Set or Jomar Heavy Weight for all threaded pipe fittings and plugs. The 3" side tee and 1" bottom drain plug are factory installed. Tighten all fittings per recognized industry installation standards.

1. Thread the bottom of the 3" side tee onto the vent riser piping. The PV-ZERO may be mounted mid-line or top mounted on a single riser or a manifolded system (see drawings, pages 9 & 10). For 2" riser piping systems, use a 3x2" NPT reducing coupling with a 3" pipe nipple at least 6" long (see drawing, page 11).
2. Make sure the PV-ZERO unit is plumb within  $\pm 3^\circ$  and not set at an angle. Failure to set in the vertical position may cause improper operation.
3. For mid-line mounting installations, install and secure the rest of the 3" discharge piping on the vent rack (refer to NFPA 30 for specific fuel system vent piping requirements). **Be sure to use a pipe wrench to counteract the tightening force to the valve!**
4. Fill the PV-ZERO unit through the side port with 1.6 liters (54 oz.) of PV-ZERO fluid (FFS p/n 407220001) provided with the unit. It may also be filled through the discharge outlet fitting (top). **Do not pour into the 3" side tee fitting!**

**Note:** To fill the fluid in the PV-ZERO, the UST (Underground Storage Tank) must be open to the atmosphere OR the inflatable test plug needs to be installed to reach the correct level. If the tank is under pressure or vacuum, the correct fill level cannot be obtained.

5. Install the side plug.
6. Perform the **Field Testing Procedure**.
7. Install the 3" pipe plug on top of the tee.
8. Attach the 3" upward-venting rain cap provided. Attach to the top of the vent pipe (mid-mount installation) or directly to the top of the PV-ZERO (top mount) **Keep the rain cap installed to minimize water intrusion, and to ensure proper operation.**

The PV-ZERO may be painted, however, do not paint over or cover the nameplate placards decals.

## Field Testing

**Note:** Compliance testing of the PV-ZERO, if required by the local air quality district, shall be conducted in accordance with California Air Resources Board (CARB) test procedure TP-201.1E and Exhibit 2 of the Executive Order. This test shall be conducted using the PV-ZERO test cap assembly (FFS p/n 407225901) with the valve in its installed condition. The PV-ZERO can be tested without removing the unit from the vent rack.

There are (3) ports on the PV-ZERO test cap assembly (see page 8):

- 1 – Schrader valve connection for the inflatable plug
- 1 – 1/4" hose barb (for pressure/vacuum supply)
- 1 – 1/8" hose barb (for manometer)

1. Remove 3" pipe plug from top of tee (if necessary).
2. Install the test cap assembly through the top of the 3" tee, allowing the inflatable plug to extend into the vent riser pipe - tighten fully.
3. Inflate the inflatable plug to 35 PSI.
4. Test per CARB TP-201.1E
5. Deflate the inflatable plug.
6. Remove test cap assembly from 3" tee.

**Recommended Maintenance Intervals**

- **Every year:** Visually inspect the housing, pipe, fittings, and rain cap for obvious signs of damage, missing parts, or fluid leaks.
- **Every year:** Visually inspect the rain cap, from ground level, for signs of bird nests or insect activity.
- **Every year:** Drain and inspect the fill fluid per the **Fluid Inspection Procedure**.

**Fluid Handling**

The PV-ZERO is filled with a silicone based fluid, p/n 407220001 (contact FFS for MSDS sheet). The PV-ZERO fill fluid is resistant to UV exposure, does not support bioactivity and is resistant to oxidation.

Since the PV-ZERO is exposed to tank ullage vapors, used PV-ZERO fill fluid may contain trace amounts of ethanol and gasoline. The maintenance technician servicing the PV-ZERO should wear appropriate eye protection and nitrile gloves when inspecting or servicing the fill fluid. Check with local and state regulations regarding handling, transportation, recycling and disposal of silicone based fluids.

**Fluid Inspection Procedure**

1. Remove the 3" NPT plug from the top of the side tee.
2. Remove the 3/8" NPT side plug.
3. Remove the 1" NPT bottom plug and drain the fluid into a clean, transparent container.
4. Visually inspect the fill fluid for debris or water contamination. Since the specific gravity of the fluid is slightly less than water, any water in the fluid will settle to the bottom. The fluid can be reused indefinitely as long as it is free of sediment and water.

Note: Clean fluid can be refilled into the valve and topped off with new fluid, or it can be completely replaced with new fluid.

5. Reinstall the 1" NPT bottom plug.
6. Refill the PV-ZERO valve with fluid through the side-port until it spills out of the port. This is the correct fill level of 1.6 liters (54 oz.).
7. Reinstall the 3/8" NPT side plug.
8. Perform the **Field Testing Procedure**
9. Reinstall the 3" NPT plug in the top of the side tee.

Only use the approved PV-ZERO fluid (P/N 407220001). Substitution of other fluids voids the warranty and can cause vapor leaks!

**PV-ZERO Specifications**

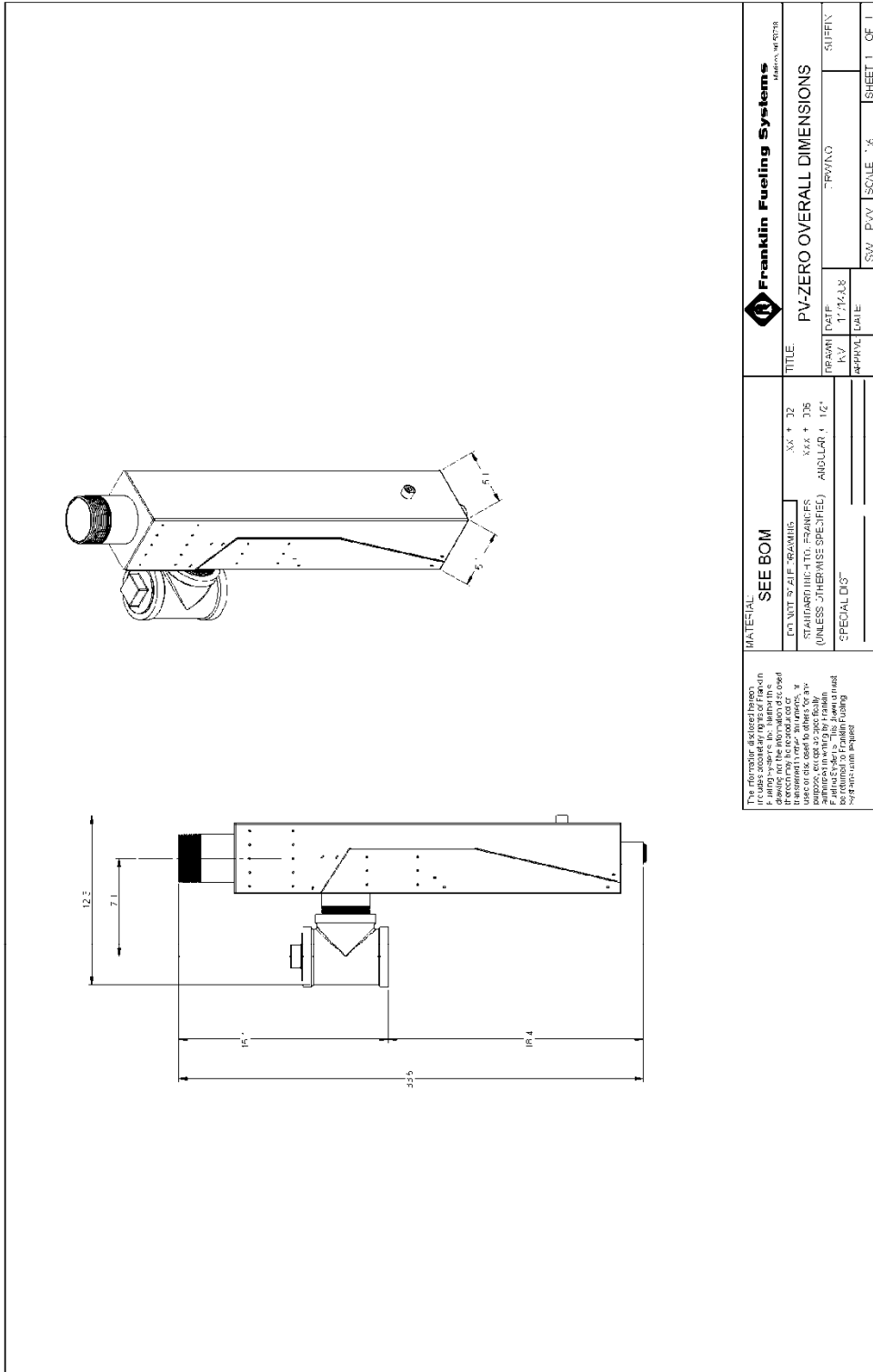
Height:	33.5"
Width:	5.0"
Length:	12.3"
Dry weight:	20#
Inlet piping connection	3" NPT
Discharge piping connection	3" NPT
Fill port	3/8" NPT
Drain port	1" NPT
Construction material	304 stainless steel
Fuel Compatibility	Gas & E85
Pressure leak rate	<< 0.05CFH at +2.0 W.C.
Vacuum leak rate	<< 0.21 CFH at -4.0 W.C.
Pressure drop at 60 cfm flow rate with tank positive pressure	14" W.C.
Pressure drop at 90 cfm flow rate with tank positive pressure	28" W.C.
Minimum operating temperature	-40°F (-40°C)
Maximum operating temperature	130°F (54°C)
Maximum test pressure	5 PSI
Maximum mounting angle deviation from vertical	3°

**Drawing List:**

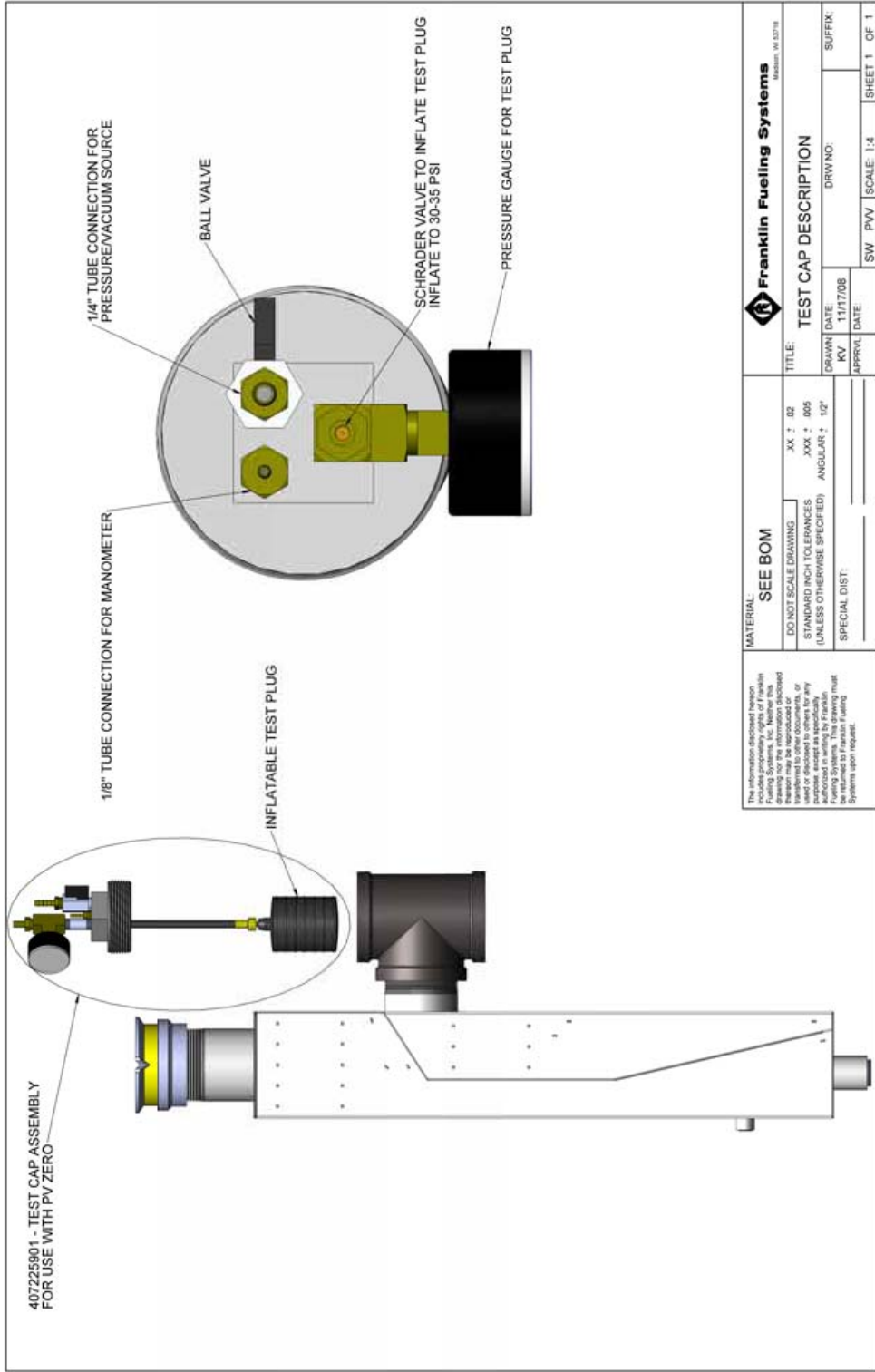
Page	Drawing Description
6	PV-ZERO Operating Assembly
7	PV-ZERO Overall Dimensions
8	Test Cap Description
9	3" Manifolder Mid Mount
10	3" Mounting Assembly
11	2" Mounting Assembly

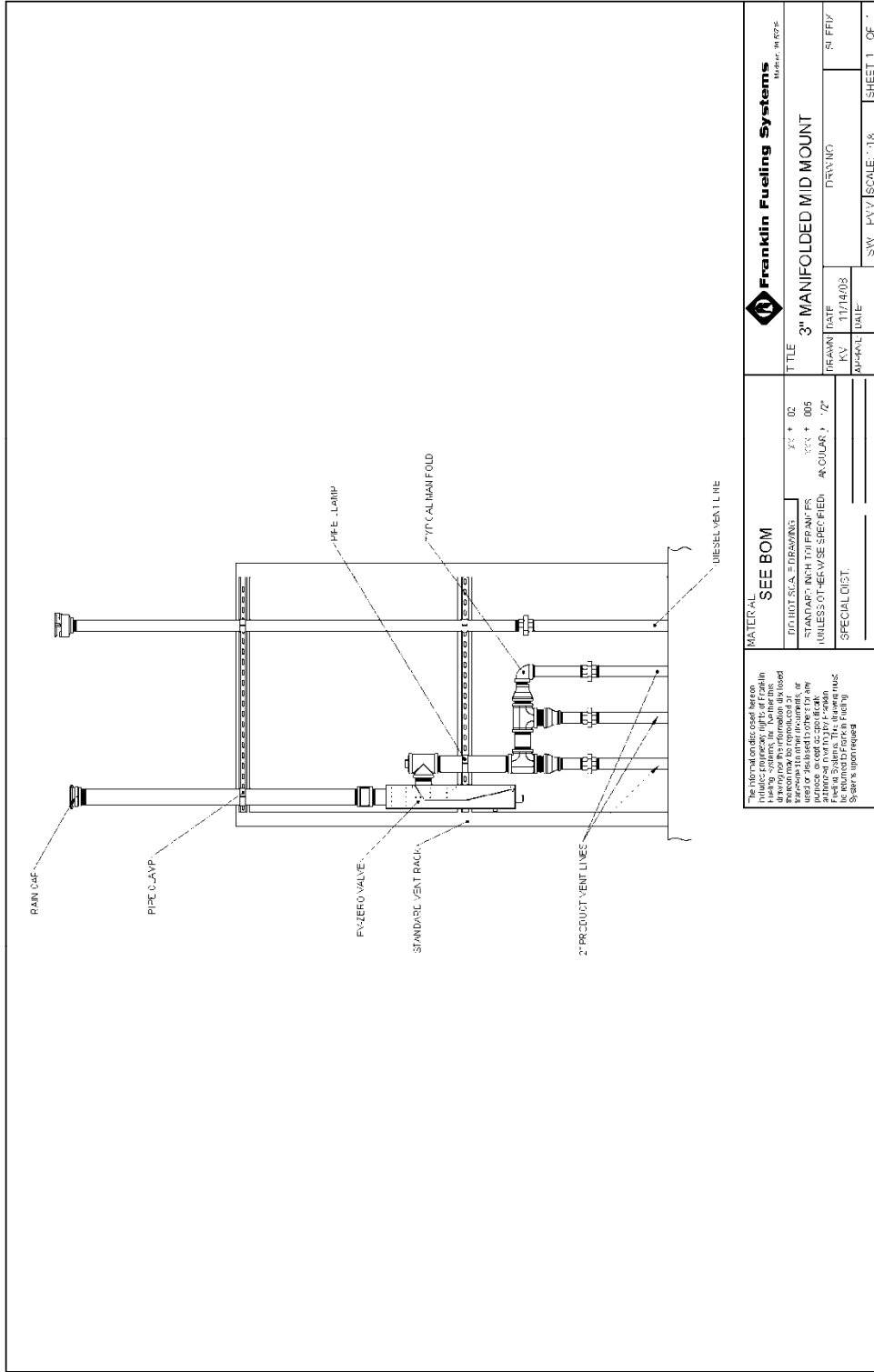
The drawings are on the following pages.



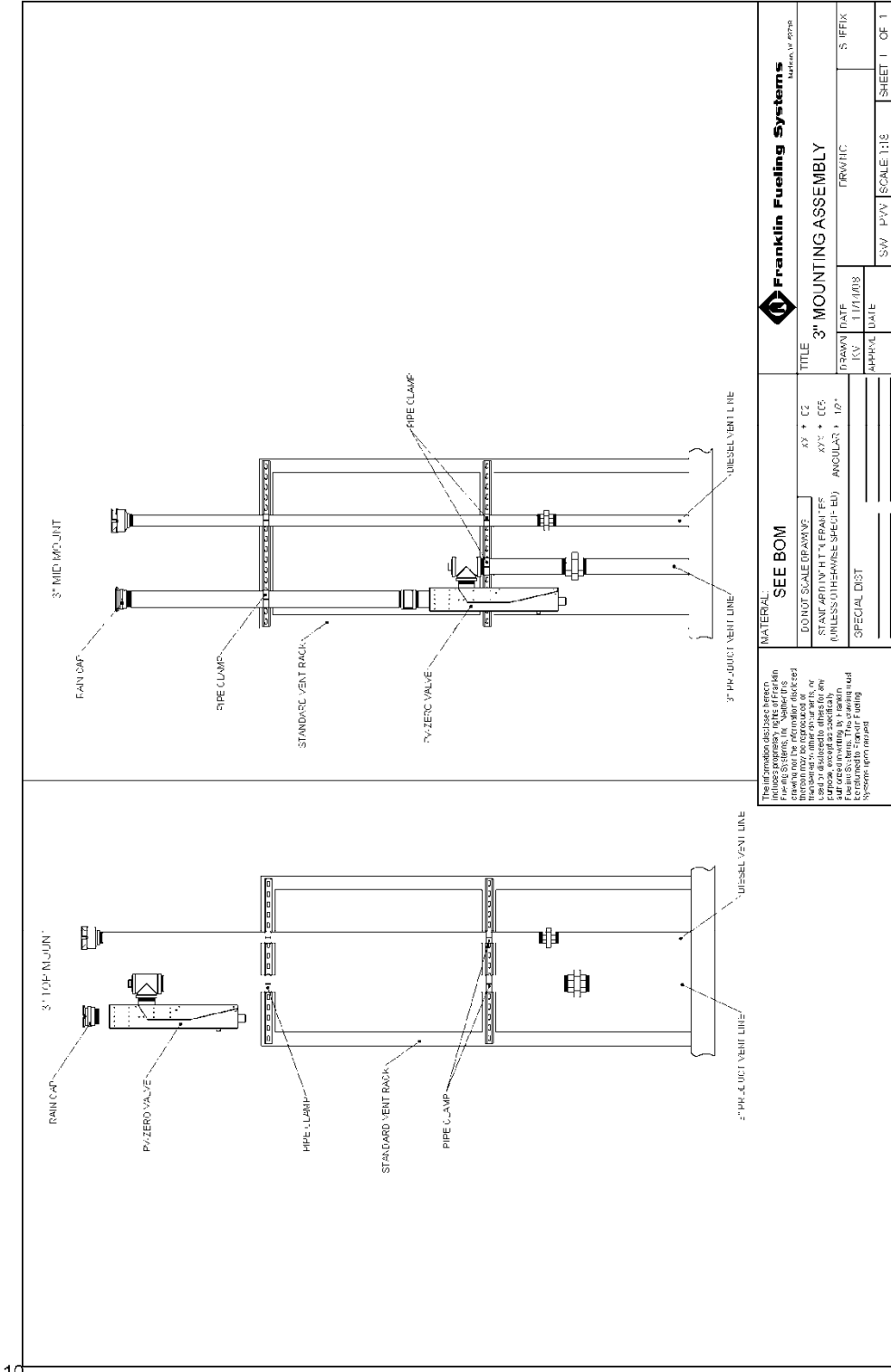


<p>The information depicted herein includes accepted rights of Franklin Electric and its subsidiaries and is provided for the laboratory use only. It is not to be used for any other purpose, and its use is limited to the specific application for which it was developed. Franklin Electric is not responsible for any damage or injury resulting from the use of this information.</p>		<p><b>SEE BOM</b></p> <p>CO. NOT TO SCALE. DIMENSIONS ARE IN INCHES UNLESS OTHERWISE SPECIFIED. ANNOTATION: 1/16"</p>	<p><b>Franklin Fueling Systems</b>  <small>MADE IN THE U.S.A.</small></p>
<p>TITLE: PV-ZERO OVERALL DIMENSIONS</p>		<p>XX + 02                  XXX + 026</p>	<p>REV: 1                  DATE: 11/16/18</p>
<p>MATERIAL: SEE BOM</p>		<p>SPECIAL DISC</p>	<p>SCALE: 1/8"</p>
<p>APPROVAL: _____</p>		<p>DATE: _____</p>	<p>SHEET 1 OF 1</p>





<p>The information described herein is the property of Franklin Fueling Systems, Inc. All rights reserved. This information shall not be reproduced or transmitted in any form or by any means, electronic or mechanical, including photocopying, recording, or by any information storage and retrieval system, without the prior written permission of Franklin Fueling Systems, Inc.</p>		<p><b>Franklin Fueling Systems</b>  <small>Member, IFAFPE</small></p>
<p><b>MATERIAL SEE BOM</b></p>		<p><b>3" MANIFOLDED MID MOUNT</b></p>
<p>DD: 1012 SCA, 2 DRAWINGS</p>	<p>3" x 02</p>	<p>TITLE</p>
<p>STANDARD: INCH TON PER AMPS</p>	<p>3" x 005</p>	<p>DRAWN DATE</p>
<p>UNLESS OTHERWISE SPECIFIED, AN ANGLE IS 90°</p>	<p>UNLESS OTHERWISE SPECIFIED, AN ANGLE IS 90°</p>	<p>APPROVAL DATE</p>
<p>SPECIALIST:</p>	<p>DATE</p>	<p>SCALE: 1:16</p>
<p>DATE</p>	<p>DATE</p>	<p>SHEET 1 OF 1</p>

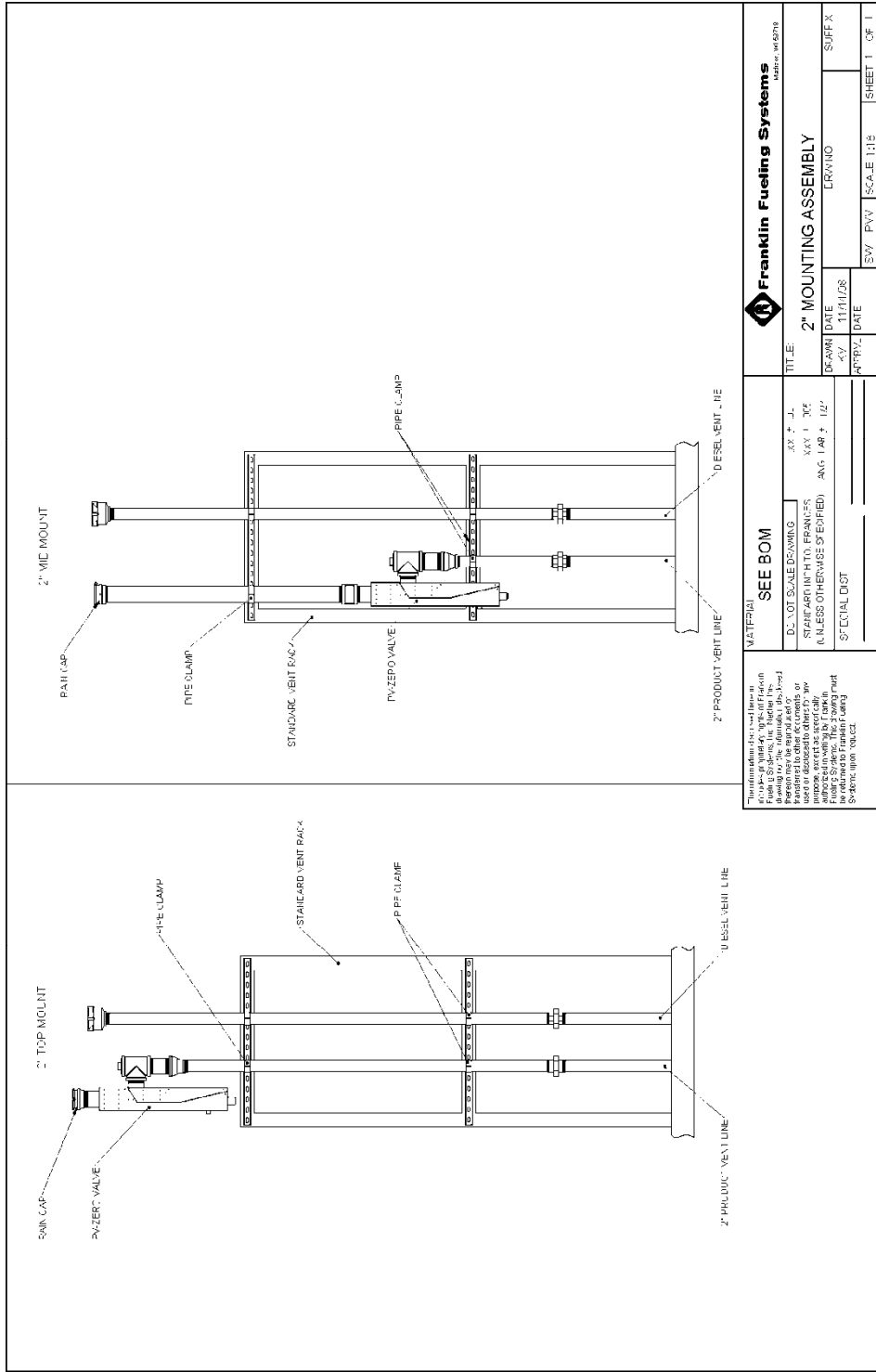


TITLE: 3" MOUNTING ASSEMBLY	
DRAWN: FRW/TIC	DATE: 11/11/08
APPROV:	DATE:
SCALE: 1:1	SHEET 1 OF 1

MATERIAL: SEE BOM
DONUT SCALE (DRAWING): X7 + C2
SCALE (FRUIT): X77 + C65
(UNLESS OTHERWISE SPECIFIED) ANGULAR: 1/16"
SPECIAL DIST:

The information disclosed hereon includes proprietary rights and is intended for use only by the person to whom it is furnished. It is not to be reproduced, distributed, or otherwise made available to other persons without the express written consent of Franklin Fueling Systems. This drawing and its contents are the property of Franklin Fueling Systems. This drawing and its contents are not to be used for any other purpose without the express written consent of Franklin Fueling Systems.





The information contained herein is the property of Franklin Fueling Systems, Inc. The information is provided for your information only and is not to be used for any other purpose, except as specifically authorized by Franklin Fueling Systems, Inc. The information is provided without warranty, and Franklin Fueling Systems, Inc. is not responsible for any damage or loss resulting from its use.

<b>Franklin Fueling Systems</b> <small>Franklin Fueling Systems, Inc.</small>	
TITLE: <b>2" MOUNTING ASSEMBLY</b>	
DWT: NOT SCALE DRAWING	DWG. NO.: 111/02
SCALE: 1/2" = 1'-0"	DATE: 11/1/02
(UNLESS OTHERWISE SPECIFIED)	APPR. DATE:
SPECIAL DWT:	SCALE: 1:15
SHEET 1 OF 1	DRAWNO:

©2009 FFS 407232001 Rev 2



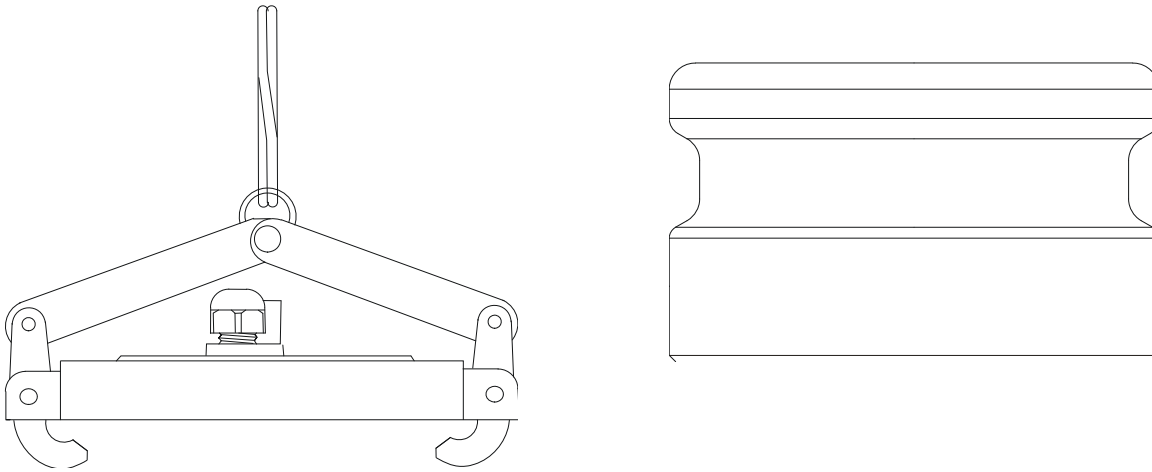
**Franklin Fueling Systems**

[www.franklinfueling.com](http://www.franklinfueling.com)

3760 Marsh Road • Madison, WI 53718, U.S.A.  
Tel: +1 608 838 8786 • Fax: +1 608 838 6433  
Tel: USA & Canada 1 800 225 9787 • Tel: México 001 800 738 7610

**Franklin Fueling Systems GmbH**  
Rudolf-Diesel-Strasse 20 • 54516 Wittlich, GERMANY  
Tel: +49-6571-105-380 • Fax: +49-6571-105-510

**Morrison Brothers Tank Gauge Port Components**  
**305XPA & 305XPA1100AKEVR (cap and adaptor kit)**  
**305 & 305-0200AAEVR (replacement adaptor)**  
**305XP & 305XP-110ACEVR (replacement cap)**



**305XP Cap**

Installation Instructions –

1. Apply a fuel resistant, non-hardening, anti-seize sealant (not adhesive) to cable connector threads. Follow manufacturer's instructions for installation of monitoring system.
2. Set cap on adapter
3. Push down on lever arms.

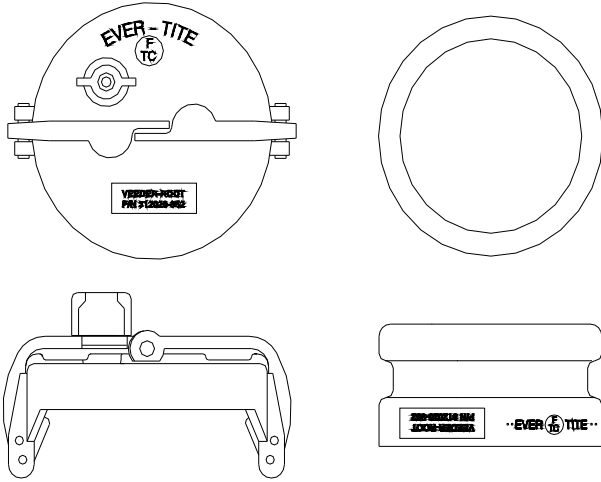
**305 Adapter**

Installation Instructions –

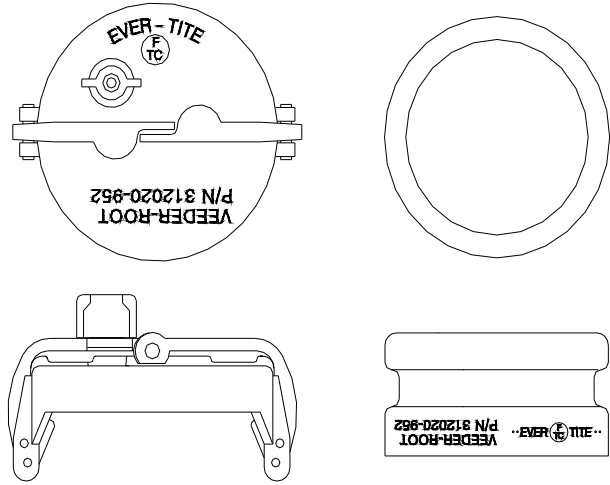
1. Apply a fuel resistant, non-hardening, anti-seize sealant (not adhesive) to body threads.
2. Thread body on to riser pipe. Torque to 23-26 ft.-lb.

## Veeder-Root P/N 312020-952 Tank Gauge Cap and Adaptor

### Original Identification Method



### New Identification Method



### Installation Instructions

Install CARB approved machined adaptor onto the riser. Apply a gasoline-resistant hardening thread sealant to the threads of the riser adaptor only. Next screw the ring from the Veeder-Root kit (P/N 312020-952) onto the riser adaptor by hand until the gasket contacts the sealing surface. Then use a torque wrench attached to an appropriate strap wrench (K-D Specialty tools nylon strap oil filter wrench P/N 3149, or equivalent) and tighten the ring to 35 – 45 ft-lbs. Loosen the cord grip nut and push the cable through the cap and cord grip, then clamp the cap onto the ring.



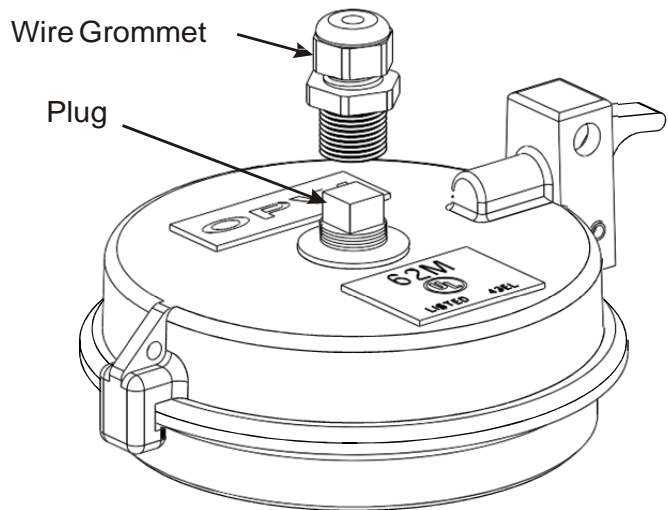
## OPW 62M Monitoring Probe Caps Installation and Maintenance Instructions

**IMPORTANT:** Please read these warnings and assembly and use instructions completely and carefully before starting. Failure to do so may cause product failure, or result in environmental contamination due to liquid leakage into the soil, creating hazardous spill conditions.

**WARNING-DANGER:** Using electrically operated equipment near gasoline or gasoline vapors may result in a fire or explosion, causing personal injury and property damage. Be sure that the working area is free from such hazards, and always use proper precautions.

Notice: FlexWorks by OPW, Inc., VAPORSAVER™ and all other OPW products must be used in compliance with all applicable federal, state, provincial and local laws, rules and regulations. Product selection is the sole responsibility of the customer and/or its agents and must be based on physical specifications and limitations, compatibility with the environment and material to be handled. All illustrations and specifications in this literature are based on the latest production information available at the time of publication. Prices, materials and specifications are subject to change at any time, and models may be discontinued at any time, in either case, without notice or obligation.

This section intentionally left blank.



**Product**

**Identification:**

**Manufacture:** “OPW”

**Model:** “62M”

**Date Manufactured (Located on underside of cap):** “MFG MMY”; MM = Month, YY = Year

**Installation and Maintenance**

1. Install the 62M Monitoring Cap onto a FSA-400(-S) Face Seal Adapter. (Optional) Apply pipe dope to nipple.
2. Tighten Monitoring Cap onto the FSA-400 (-S) adapter with a strap wrench. Torque to 90 ft-lbs to 110 ft-lbs.
3. Remove plug and install wire grommet if needed. Apply gasoline resistant pipe dope to NPT threads.

**Torque values:**

62M 3/8 NPT Thread and Dome Nut; 40 to 50 in-lbs.

62M 1/2 NPT Thread and Dome Nut; 80 to 90 in-lbs

62M-MA 3/8 NPT Thread: 33 to 40 in-lbs. Dome nut: 22 to 27 in-lbs

62M-MA 1/2 NPT Thread: 44 to 50 in-lbs. Dome nut: 29 to 34 in-lbs.

**Maintenance:**

Annually inspect O-ring and Gasket seal for nicks, tears or deformations. If required, replace with the following OPW Part Numbers:

<b><u>Part Number</u></b>	<b><u>Description</u></b>
201954	O-Ring
H09039M	Gasket

This section intentionally left blank.

This page intentionally left blank.



3250 US 70 Business West  
Smithfield, NC 27577  
Customer Service: 1-(800) 422-2525  
Technical Service and Questions:  
1-(877) OPW-TECH  
[www.opwglobal.com](http://www.opwglobal.com)

## Installation and Maintenance Instructions McGard Fuel Lock

# Fuel Lock Installation Guide

Note: A removal and Installation of components must be performed by technicians certified by the appropriate manufacturer of the Phase I system.

For a video of these instructions go to:  
<http://mcgard.com/index.php/municipal-security-videos>

**1** Remove spill container cover.



**2** Remove seal cap.



**3** Remove adapter.



**4** Attach lock onto hanger.



**5** Place key tool in lock and tether to wrist.



**McGard**   
Headquarters: 3875 California Road, Orchard Park, NY 14127 U.S.A.  
**888-888-9192**



- 6** Holding hanger, place the lock in pipe/fitting. If installing a lock with dual cross-webs or applications without a drop tube and/or overflow valve, proceed to step 7. If overflow valve is present, rotate to align the stick opening (larger of the two openings) in the center of the lock with the opening in the overflow prevention valve (viewed down inside the pipe).



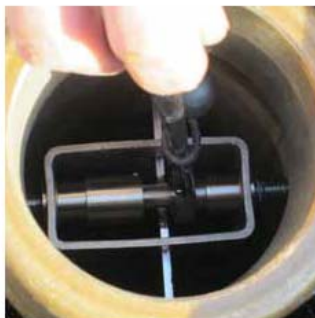
- 7** Tighten one mounting screw until tip is in contact with ID of pipe/fitting, while roughly centering the lock in the pipe/fitting. Leaving lock and hanger in place, remove and reinstall key tool to tighten second mounting screw until snug enough to hold lock in place. Do not over-tighten.



- 8** Remove key tool and hanger and tightly reinstall adapter.



- 9** Re-install key tool into lock, through adapter and tighten screws firmly. Remove key tool.



- 10** Install seal cap.



- 11** Install spill container cover.



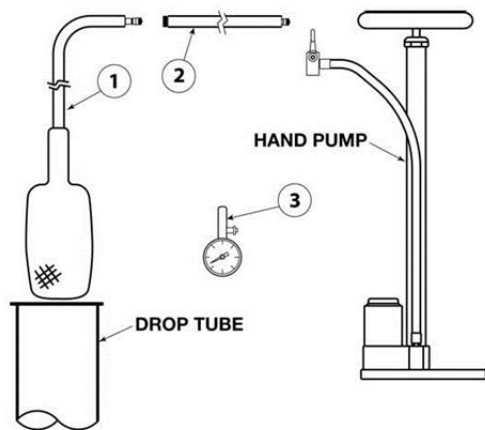
**McGard**   
 Headquarters: 3875 California Road, Orchard Park, NY 14127 U.S.A.  
**888-888-9192**

## Installation and Maintenance Instructions McGard Bladder Plug

### Isolation Instructions for Drop Tubes Utilizing a McGard Fuel Lock

Spill containment drain valves and 4" ID drop tubes must be isolated when performing CA EVR leak test procedures identified in TP-201.1D. In applications using the McGard Fuel Lock, a nitrile test bladder (balloon) encased in a protective fabric bag is used to plug the tube, as follows:

1. The bladder (Item #1) is inserted (fully deflated) through the lock and into the drop tube and positioned at desired point of isolation. **To achieve a bubble tight seal, the fabric protection bag must be soaked (wetted) with oil prior to use. This can be any available motor oil such as 30W or 10W-30.** A 3' extension hose (Item #2) may be used if deeper test point is required.
2. After installation, the bladder is inflated to 15 psi utilizing a basic hand pump or low pressure compressed air (**DO NOT OVER-INFLATE**) and a pressure gage (Item #3). All connections are standard tire valve stems (Schrader Valves).
3. After inflation, disconnect pump and/or gage so test bladder hose can be curled and placed into the drop tube.
4. Install test cap on product adapter and perform leak test procedure.
5. After testing is completed, connect pressure gage (with bleeder valve, Item #3) or remove needle from Schrader valve and manual bleeder valve to fully deflate test bladder. Remove the test bladder from the drop tube and store in a clean (dirt free) plastic bag.



Item	Part Name	Manufacturer	Manufacturer Part No.	Qty
1	Bladder Plug	COB Industries	PSI104	1
2	3 ft. Extension Hose	Cherne Industries	274038	1
3	Pressure Gage w/Bleed Valve	Westward Tools	2HKY6	1